

Academy Walnut

Luxury Bathroom



Travelling through



Oasis offers so much more than a selection of furniture. Indeed, the company aims to propose a complete and coordinated interior design, inspired by an idea: the beauty of 1900. Nevertheless Oasis also looks at the decades of great Italian design and architecture to capture the secret of blending different raw materials in a new, unique and universal design.



Oasis, a story in time

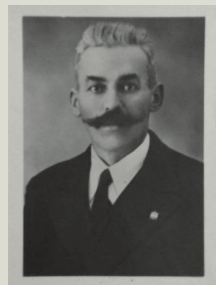

1908

Floriano Quaia opens his first carpentry workshop: a small studio where furniture is made with the aim of lasting a lifetime.



1945

Bernardo Quaia, son of Floriano, sets down the foundations of a company where the first pieces of decorative furniture would later be developed.



1972

Francesco, Bernardo's son, builds a factory and creates - using his surname - an actual brand. Together with his brother Floriano, he sets up Arredamenti Quaia.



1980

Arredamenti Quaia participates in the Salone del Mobile, Milan for the very first time. The accompanying burst of innovation marks a turning point for the company which sets its sights on ever broader horizons.



1984

During the flurry of the Eighties, Francesco Quaia establishes the Oasis brand, branching out into the production of bathroom furniture which thereafter becomes part of the company offer.

2012

The Home line is completely revised and relaunched with the aim of offering, under the Oasis label, a complete and coordinated luxury interiors package inspired by the language of cosmopolitan and contemporary style.



The New Millennium

At the turn of the Millennium, an impetus of change, of fresh new ideas, sweeps through the company in the form of the next generation, Francesco's three children: Francesca, Federica and Lorenzo.



Nowadays

The company is a century-old family business characterised by courage, tradition and a strong identity. It has market presence in more than 25 countries, the main ones being: Russia, Ukraine, the United Kingdom, Germany, France, Switzerland, Belgium and the United States. The Oasis production portfolio includes a wide range of furniture collections for the Home, the Bathroom and the Contract industry for the construction of projects for both residential and professional purposes.

2013

The year sees monobrand flagship showrooms opening in both London and Hong Kong.

The future of italian know-how.

There is only one area of Italy where the air can blow in from foreign lands, that place is Friuli. And along with that wind comes history, style and certain ways of thinking. It is here that the story of Oasis began, the result of a refined and eclectic merging of different cultures, civilisations, languages and cuisines often referred to around the world as "Italian style".

Francesca Quaia

The eldest, Francesca, is the first to work alongside her father in the business. By assuming responsibility in 2001 for the commercial direction of the company, is pivotal in steering it along the road to internationalisation.

Federica Quaia

Second daughter Federica, having specialised in the worldwide branding of luxury goods, takes over all aspects of image and communication within the company in 2006, thus assuming marketing and artistic control.

Lorenzo Quaia

Third-born Lorenzo completes the transition to the fourth generation in 2008. Specialising in project research and development as well as highly technical products, he becomes head of the technical production division.



ACADEMY

LUXURY COLLECTION

Academy, one of the best loved ranges in the Oasis Luxury Bathroom Collection, is being launched in a new edition!

For those who wish to combine the sensation of natural wood with exquisite materials such as marble, crystal and fine metal finishes, the new Ribbed Walnut version offers a wealth of design possibilities!

The vanities can be co-ordinated with a wide selection of accessories and complementary items: elegant ottomans and benches, mirrors in bronze or smoke variations, lights, tall units and towel holders, providing a 'total look' to appeal to even the most discerning of clientèle.

Displaying beautiful Italian craftsmanship that echoes the majesty of "salle de bain" culture, the Oasis Luxury Bathroom Collection creates spaces which exude warmth and sophistication, perfect for moments of relaxation, contemplation and pampering.

The One and Only





ACADEMY AC23

L190 x W53 x H200 cm

Finishes: E012 Walnut finish with ribbed decoration and gold metal finish. Bronze mirror shelf.
Washbasin & Top: Bianco Statuario marble top and two undercounter washbasins in white ceramic.

Mirror: ACADEMY, 190 x 2 x 100 cm; **Wall Lamp:** DUCALE FLUTE - Down version - in gold metal finish and "Kube" decorative glass.

Tap: FORTUNY in gold metal finish. **Accessories:** DÉFILÉ towel holder in gold metal finish; **Pouf:** 39 x 39 x 72 cm, velvet (Cat.B).

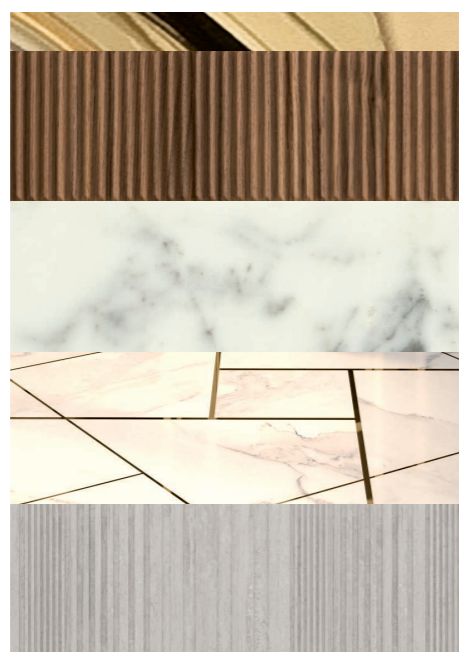
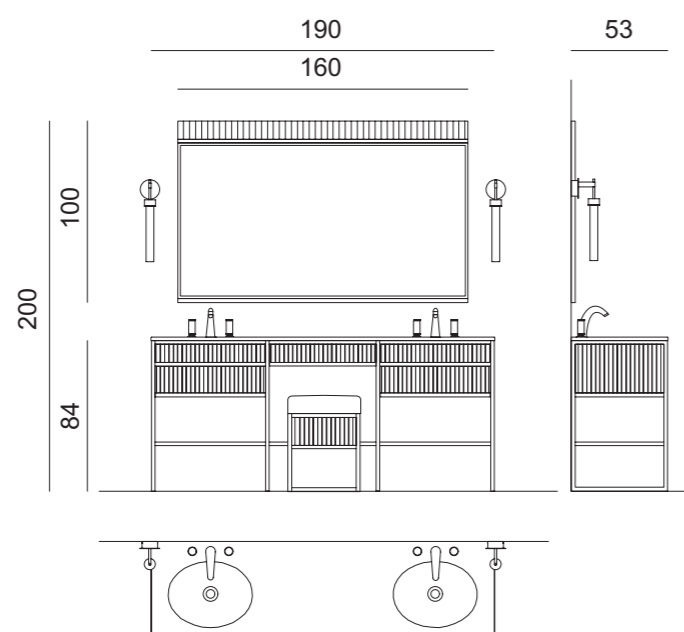







ACADEMY Dressing Table

L120 x W41 x H134 cm

Finishes: E012 Walnut finish with ribbed decoration and gold metal finish.
Bianco Statuario marble top. Integrated mirror with LED lighting.
Pouf: Eleonor, velvet (Cat. B).

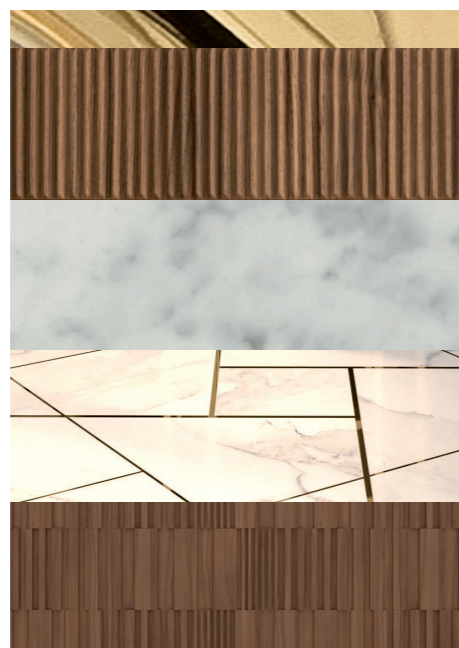
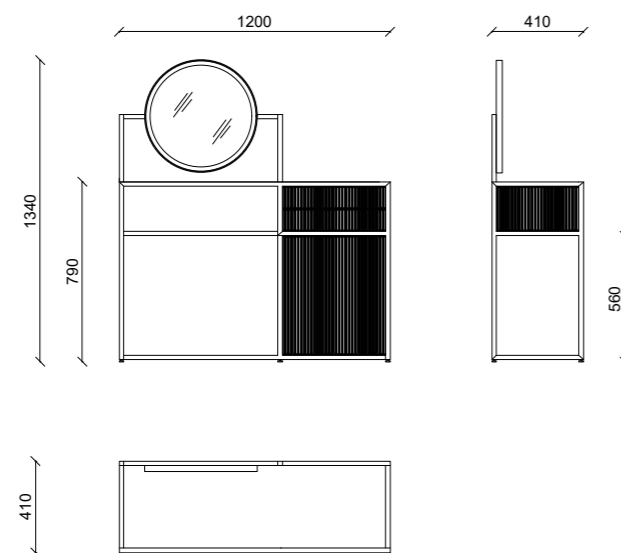





ACADEMY AC24

L160 x W53 x H200 cm

Finishes: E012 Walnut finish with ribbed decoration and gold metal finish. Bronze mirror shelf.
Washbasin & Top: Emperador Dark marble top and two undercounter washbasins in white ceramic.

Mirror: ACADEMY, 160 x 2 x 100 cm; **Wall Lamp:** DUCALE FLUTE - Up version - in gold metal finish and "Rhombus" decorative glass.

Tap: CHARLOTTE in amber finish and gold metal finish. **Accessories:** DÉFILÉ towel holder in gold metal finish; **Free-standing Tall Unit:** 50 x 35 x 156 cm; **Small Bench:** 90 x 39 x 53 cm, fabric (Cat.D).

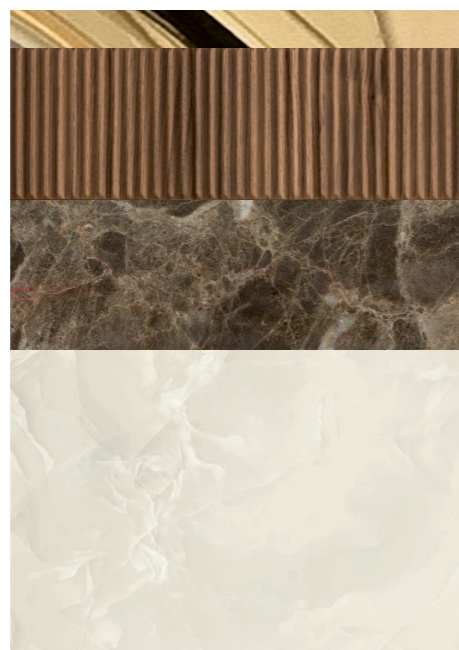
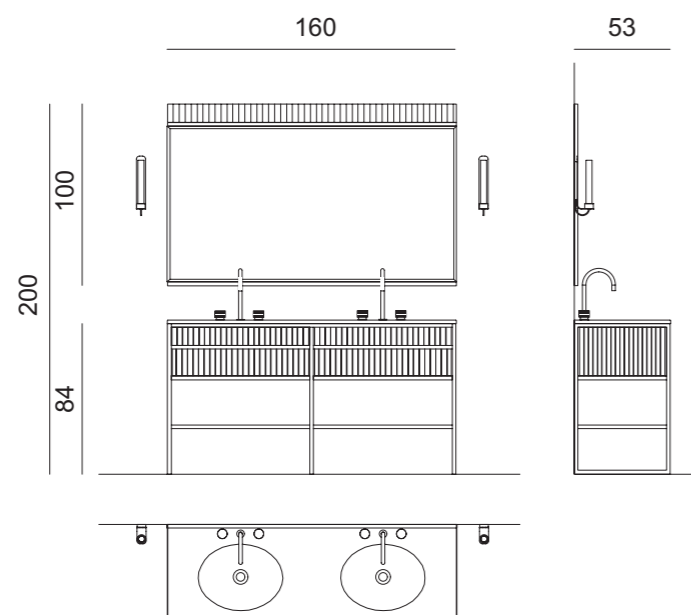













ACADEMY AC25

L85 + L85 x W53 x H200 cm

Finishes: E012 Walnut finish with ribbed decoration and chrome metal finish. Bronze mirror shelf.

Washbasin & Top: Nero Marquina marble top with undercounter washbasin in black ceramic.

Mirror: ACADEMY, 85 x 2 x 100 cm; **Wall Lamp:** DUCALE SPHERA - Down version - in chrome metal finish and "Rhombus" decorative glass.

Tap: CHARLOTTE in black finish and chrome metal finish; **Accessories:** DÉFILÉ towel holder in chrome metal finish;

Tall Unit: 35 x 35 x 156 cm; **Wall Unit:** 30 x 25 x 110 cm, **Towel Holder:** 50 x 39 x 84 cm;

Dressing Table: ACADEMY, 91 x 53 x 78 cm.

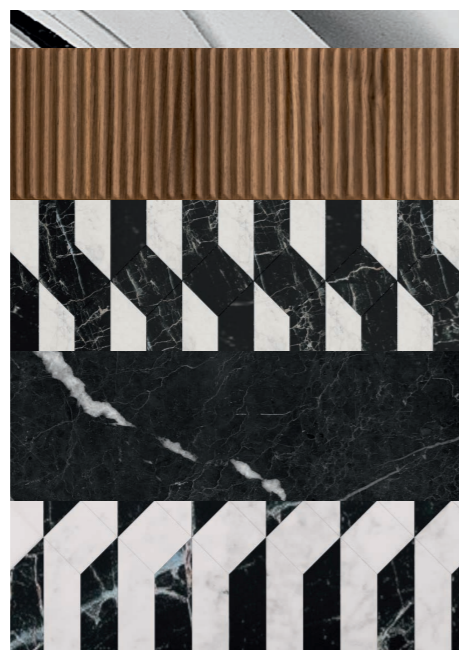
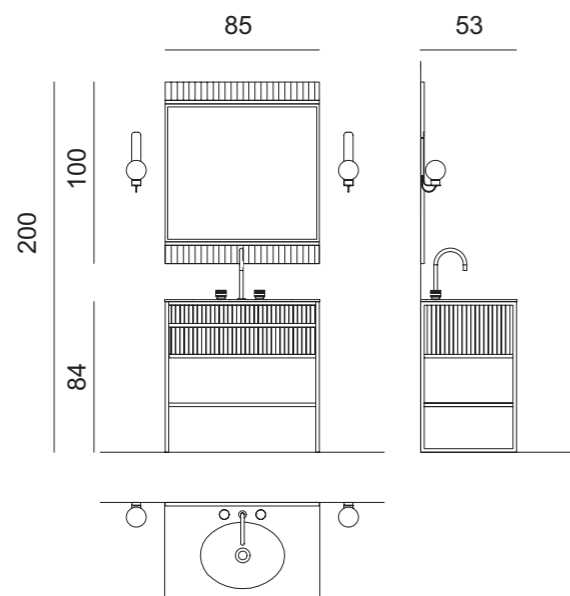



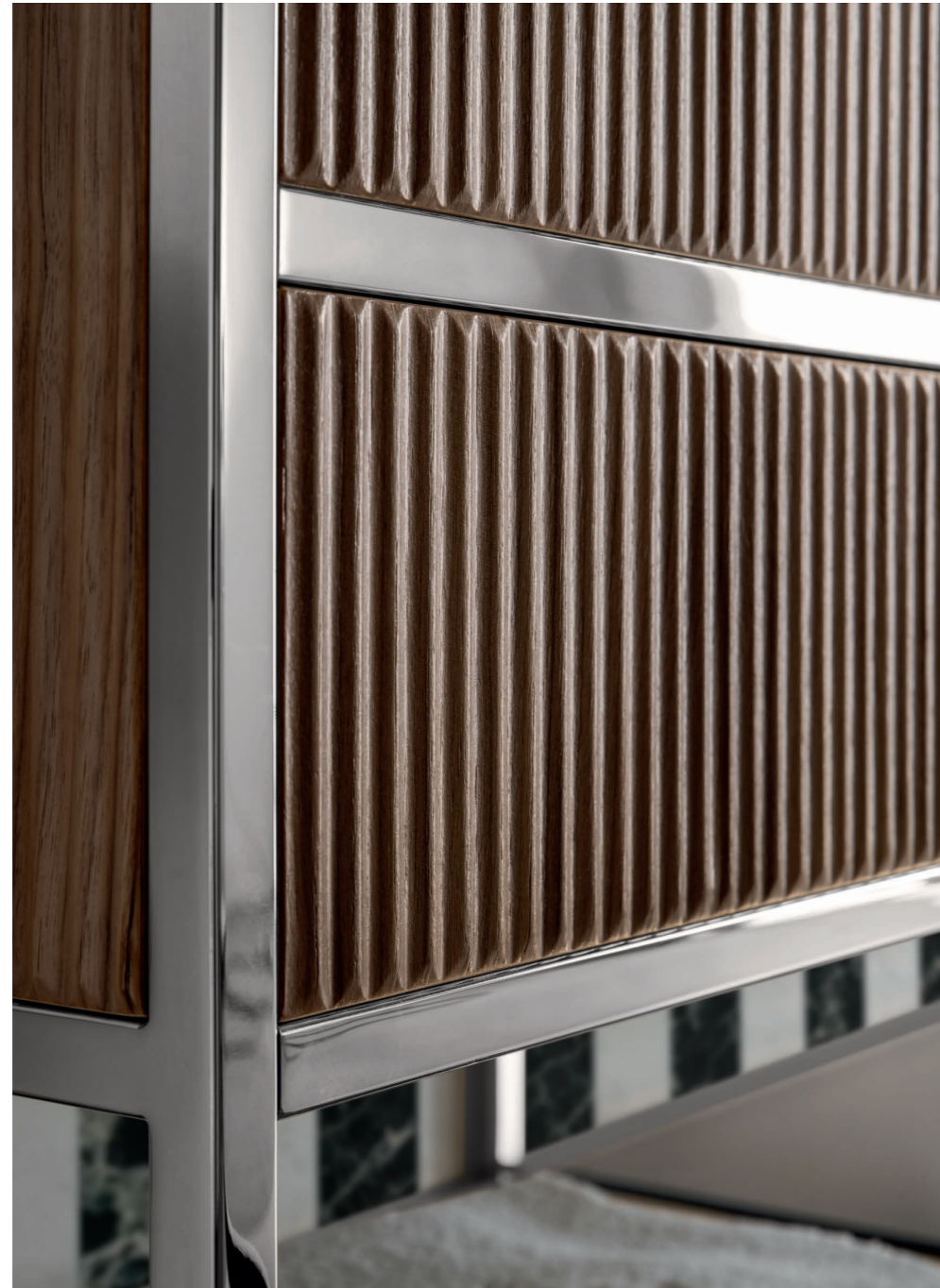







ACADEMY AC26

L110 x W53 x H200 cm

Finishes: E012 Walnut finish with ribbed decoration and gold metal finish. Bronze mirror shelf.

Washbasin & Top: Calacatta Oro marble top and undercounter washbasin in white ceramic.

Mirror: CASABLANCA, 70 x 4 x 100 cm; **Wall Lamp:** DUCALE SPHERA - Up version - in gold metal finish and "Rhombus" decorative glass.

Tap: VENICE in gold metal finish; **Accessories:** SQUARE towel holder in gold metal finish;

Suspended Tall Unit: 35 x 35 x 165 cm; **Small Bench:** 90 x 39 x 53 cm, fabric (Cat.C)

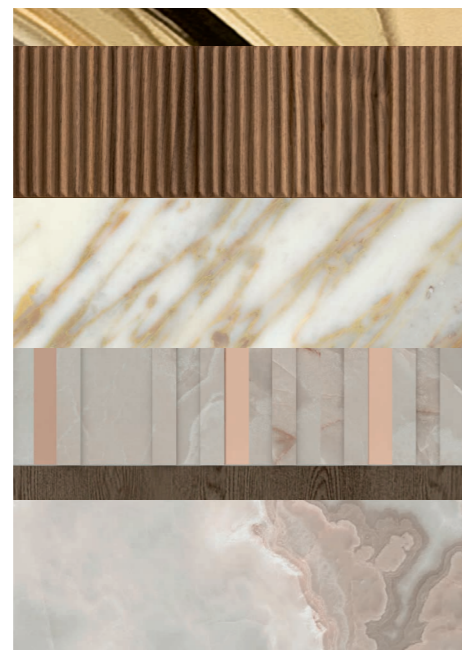
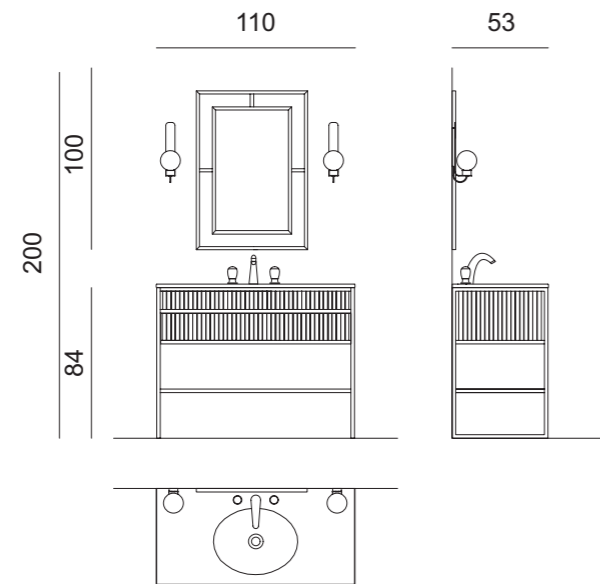











ACADEMY

WALNUT VERSION

TECHNICAL DATA

FINISHES

Front Panels



Ribbed Walnut

Metals



Gold



Chrome

Washbasins



Black ceramic washbasin
54 x 43 x 19 cm



White ceramic washbasin
54 x 43 x 19 cm



Integrated glass top

Marble Tops



Lasa Fantastico

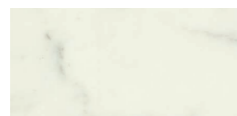

Bianco Statuario

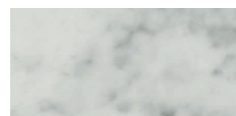

Bianco Carrara



Bardiglio Nuvolato



Calacatto Oro

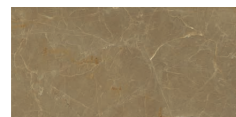

Emperador Light

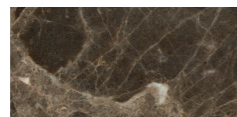

Emperador Dark

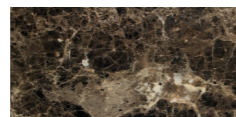

Mystic Brown

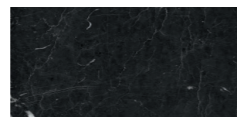

Nero Marquinia



Nero Assoluto



MODULARITY

Walnut Ribbed Decoration

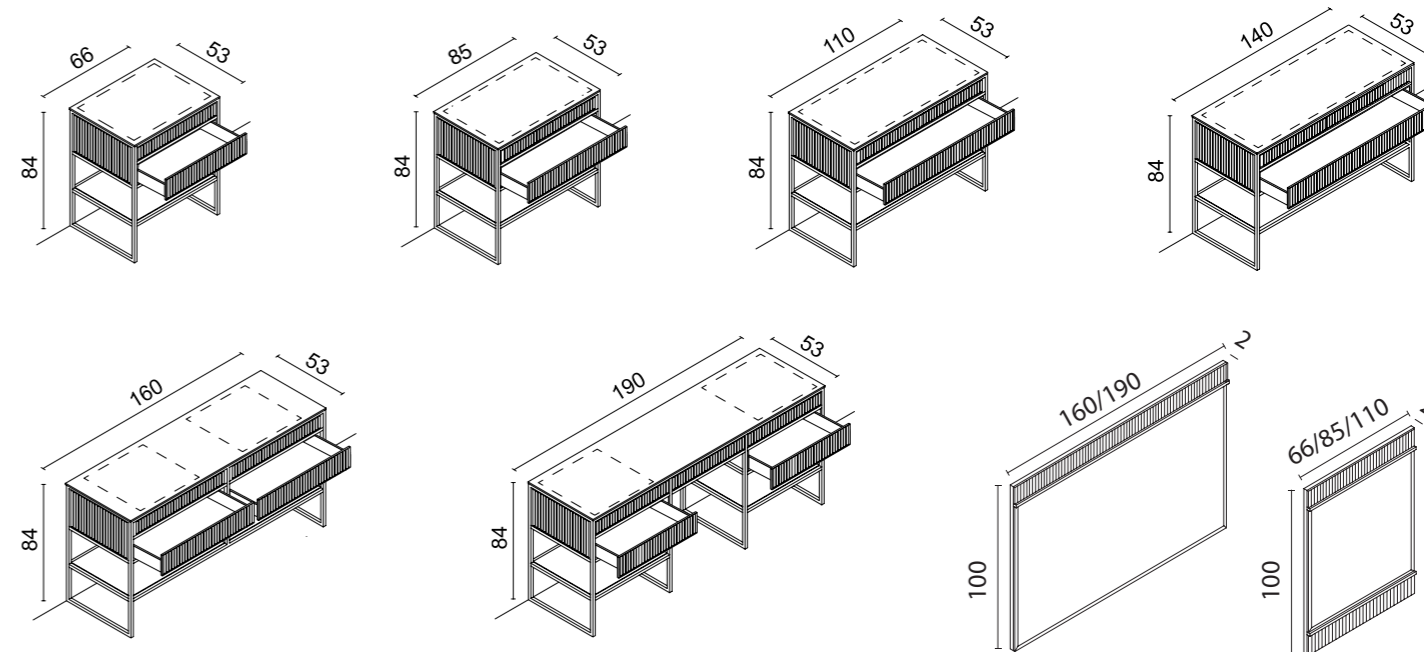

COMPLEMENTS

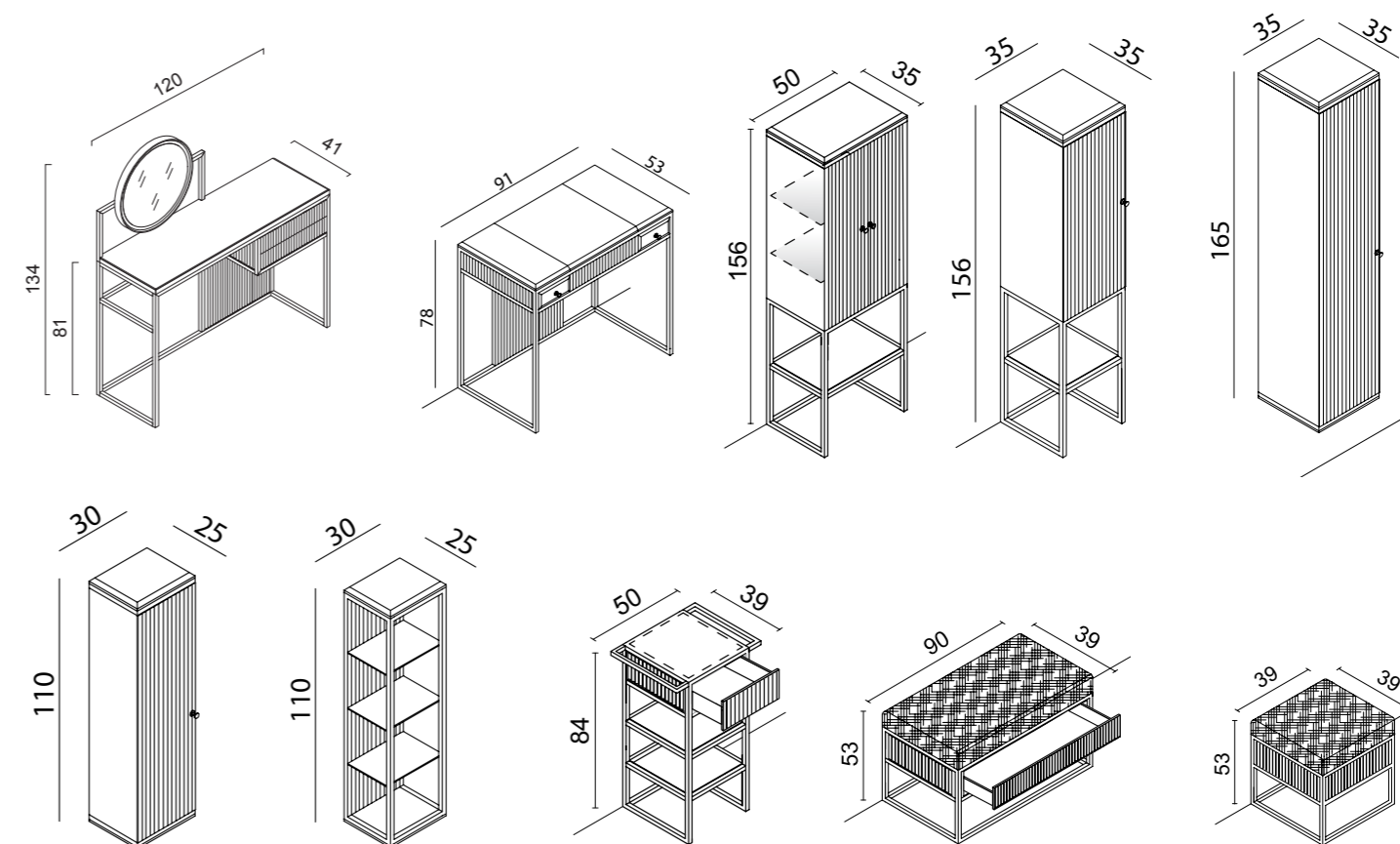



MADE IN ITALY

100% designed and made in Italy.

All Oasis products are protected by registered trademarks.

Oasis reserves the right to make all necessary modifications (in matters of colour, size and technical details) to its products in order to enhance their use and esthetic value.

Furthermore, it may suspend their production at any moment without notice. Such instances may not be subject to any claim on the part of the client.

Oasisgroup declines all responsibility for any possible uncertainties arising from misprints in this catalogue.

Edi.21 - Rev.00



Oasis Srl - Via Favola,19 - 33070 Polcenigo - Pordenone, Italy - T +39 0434 654752 - F +39 0434 654850
info@oasisgroup.it - www.oasisgroup.it



www.oasisgroup.it