

Collection 2020

Contents **p.3**

Discover Leolux **p.4**

Sofas **p.32**

Armchairs **p.78**

Chairs **p.107**

Tables **p.123**

Accessories **p.152**

Product information **p.170**

4 Discover Leolux

- 6 A product of generations
- 16 A product of individuality
- 22 A product of quality

32 Sofas

- 34 Overview sofas
- 36 Adartne
- 38 Arabella
- 40 Bellice
- 46 Bora Balanza
- 48 Bora Bora / Bora Bèta
- 50 Devon
- 52 Elias
- 54 Flint
- 58 Guadalupe
- 60 Gynko
- 64 Mayon
- 66 Nardo
- 68 Ponton Next
- 70 Rego
- 76 Tango
- 77 Vol de Rêve

78 Armchairs

- 86 Overview armchairs
- 82 Cantate
- 84 Caruzzo
- 88 Darius
- 89 Dolcinea
- 90 Hilco
- 91 Indra
- 92 Jill
- 93 Kikko
- 94 Lloyd
- 95 Mayuro
- 96 Pallone
- 98 Papageno
- 100 Parabolica
- 102 Scylla
- 104 Volare

106 Chairs

- 108 Overview chairs
- 110 Callas
- 112 Caron
- 113 Ditte / Didore
- 114 Freyr
- 115 Mara
- 116 Mime
- 118 Talos
- 120 Tamarinde

122 Tables

- 124 Overview coffee tables & tables
- 126 Aditi
- 127 Cimber
- 128 Coda
- 130 Griffio
- 131 Iduna
- 132 Liliom
- 134 Lys
- 135 Ninfea
- 137 Portello
- 138 Prismo
- 140 Rolan
- 142 Tampa
- 144 Bondi
- 146 Columna
- 148 Kalia
- 150 Yama

152 Accessories

- 154 Overview Accessories
- 156 Cosy Cushions
- 157 Cushion Lusso
- 158 Polaris
- 159 Sashiko
- 160 Topsy Turvy
- 161 Amund
- 162 Girisha
- 162 Izem
- 163 Mizu
- 164 Patna
- 164 Sperto
- 165 Amulet
- 165 Capri
- 166 Funo
- 166 Qone
- 1677 Overview footstools

170 Product information

- 172 Index
- 173 Icons
- 174 Your Leolux in the best condition
- 176 Service and warranty
- 220 The most stunning materials
- 232 Leolux Design Centers

Purely personal - At Leolux we take pride in focusing our full attention on realising your dream interior. Our family company has been building bespoke contemporary furniture for enthusiasts across the world since 1934. Enthusiasts like you.

Every day we combine the expertise of designers, craftsmen and artists to manufacture furniture that is a perfect match to your personal requirements. And that's something we do well at Leolux. We have a wide range of design, upholstery and comfort options so you don't need to compromise on anything.

The finish of every detail of our furniture is a true reflection of our craftsmen's focus and expertise. They manufacture perfect products from the most beautiful materials. Each item of furniture is in perfect balance, combining form and function. Pure design that is made especially for you.

Discover Leolux



1969

A product of generations

Leolux is now sold worldwide and some 350 people work for the company. But Leolux also has a great heritage going back to the 1930s. It's a story of innovation and entrepreneurship; a story of generations.

Leolux has become an established name over the past 86 years. Innovation and change have been a constant driver for that development.

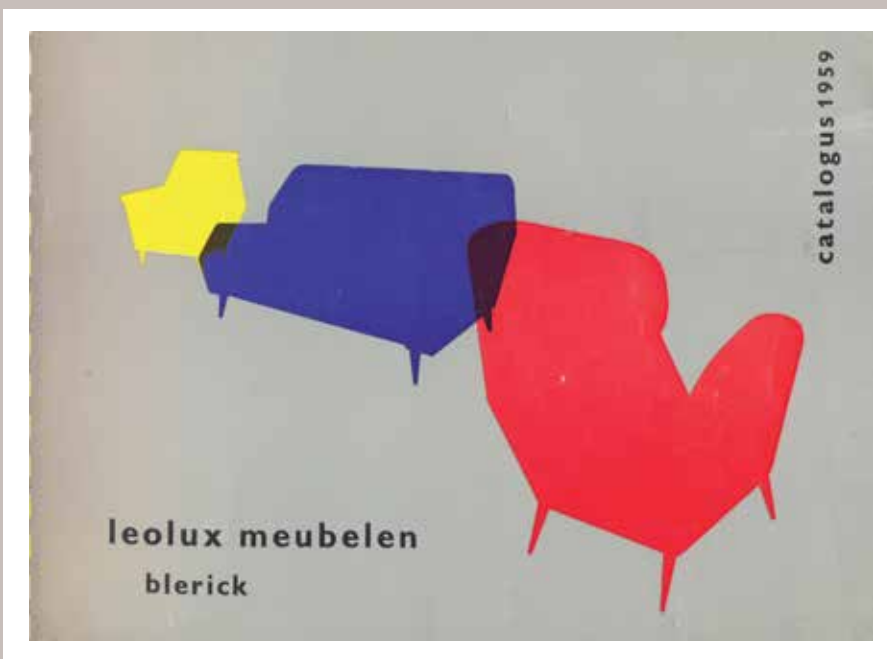

Catalogue 1959

The Zuid-Nederlandsche Clubmeubelfabriek (ZNC) was established in Venlo in 1934. With just a few employees ZNC produced traditional furniture, including club armchairs and couches. Brothers Jan and Ton Sanders acquired this small company shortly after World War II. Initially ZNC continued producing traditional furniture, but the ambitious company was determined to develop its own, more exclusive look.

Modern furniture

A few years later, the Sanders brothers started producing contemporary furniture. Inspired by Italian and Scandinavian design, they discovered contemporary materials including vegan leather and innovative production techniques. They incorporated the contemporary furniture in a separate collection, which they called 'Leolux'. 'Leo' refers to the lion in ZNC's logo, and 'lux' to the furniture's luxury character.



The Leolux woodworking department in 1970.

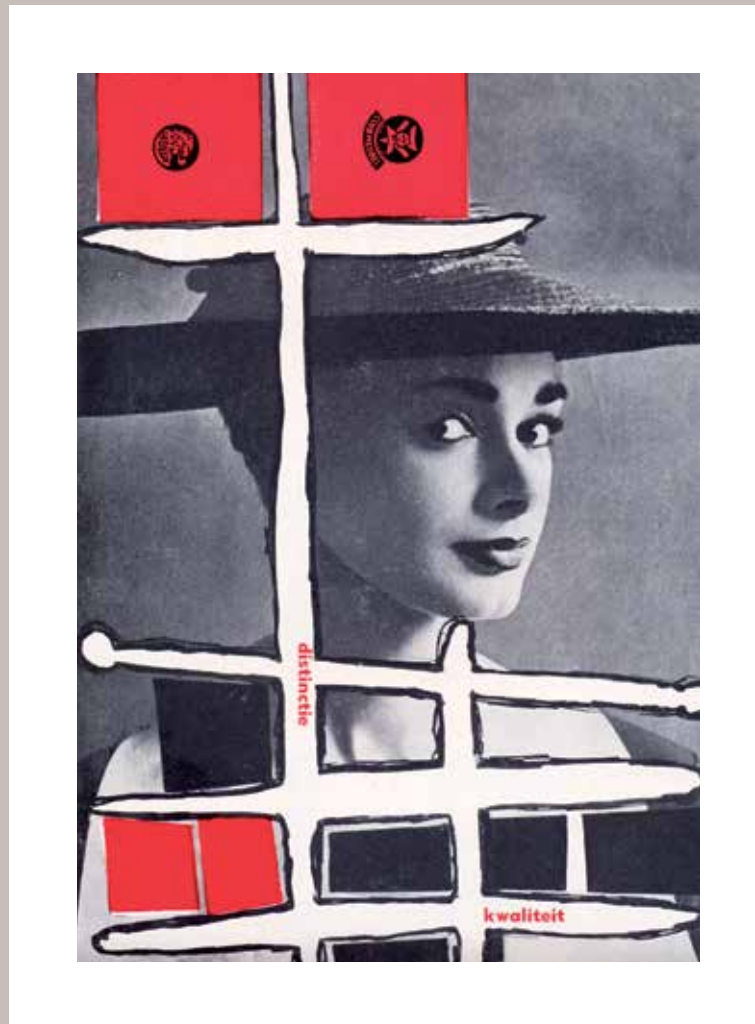

Page from the contemporary ZNC brochure dating from 1956

New enthusiasts

Leolux started to focus directly on consumers during the 1960s, with advertisements published in consumer magazines to inform new enthusiasts about the models produced in Venlo. The collection also became bolder at this time and the company opened its first factory showroom, the predecessor of the current Design-Centers. A decade later, when a large proportion of the European furniture industry was wiped out following an economic crisis, Leolux managed to hold its head above water by investing in people and developing international sales to Belgium and Germany.

Innovative design

A new generation took the helm in the early 1980s. Jeroen Sanders (son of founder Ton Sanders) and Johan van Beek continued along the course set by the founders but with some changes. The collection was expanded to include innovative products such as Bora Bora and Mink from designers including Axel Enthoven (B) and Jan Armgardt (D). Wayward advertising campaigns and innovative photography were introduced to promote the collection, because design is more than form alone. The slogan during these years was "Design tells about life". This is how the second generation helped the company take off.

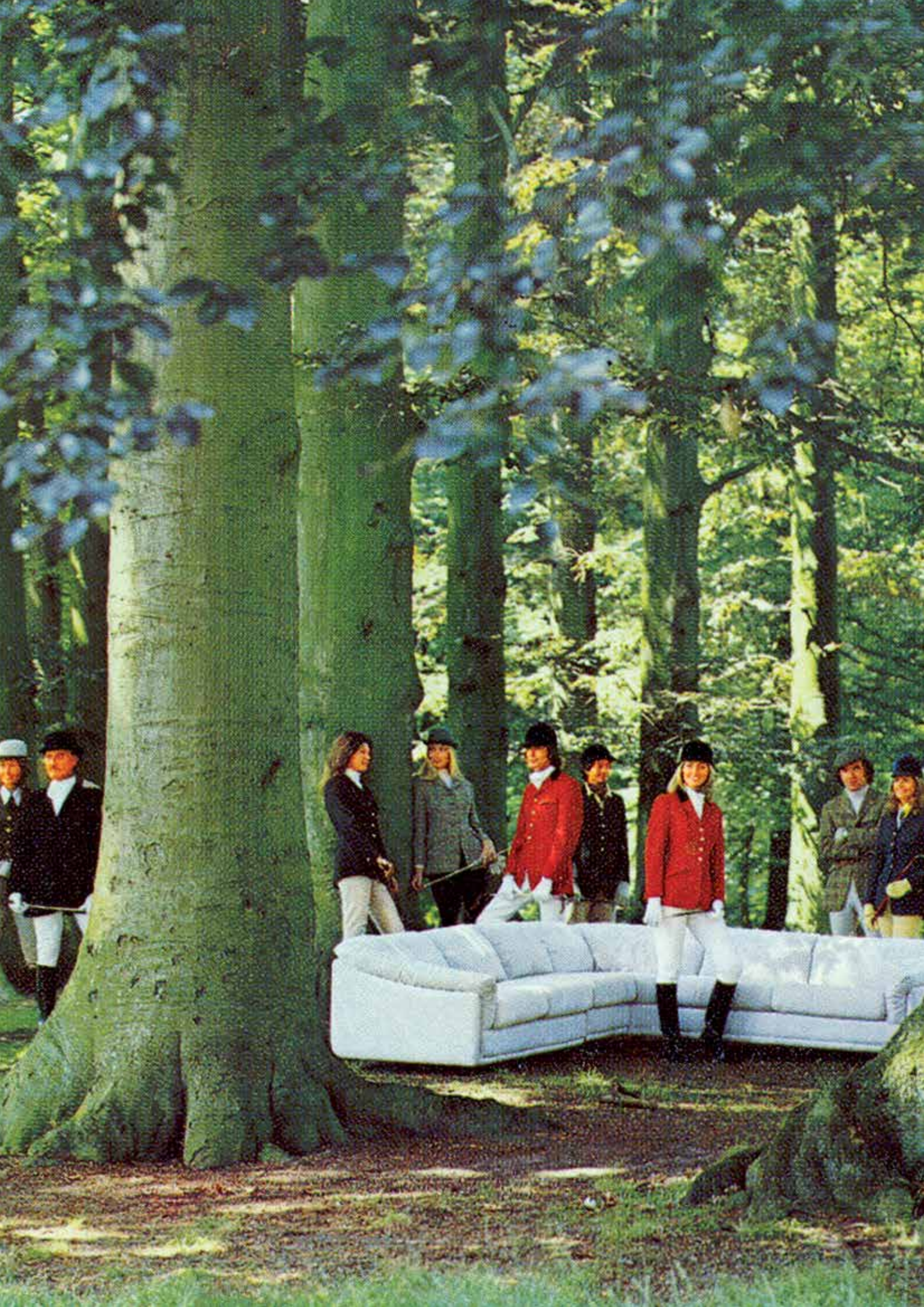



Model 901 Pallone. Designed in 1989 for the House of the Future and still in the Leolux collection.

Innovative partnerships

To safeguard quality, Leolux invested in contemporary production methods, such as the first computer-controlled leather cutting machines and logistics systems, which gave Leolux the flexibility to keep on creating new collections. Leolux introduced its first electrically-adjustable furniture at the turn of the new millennium, and started to collaborate with well-known partners, including home electronics manufacturer Philips. Art started to play an increasing role in communications and in how the furniture was presented. This made Leolux one of the top European manufacturers and they started to export furniture across the entire world. Sanders and Van Beek developed the Leolux visitor center Via Creandi in 2007. Every year, the visitor center offers many hundreds of consumers a look behind the scenes.



A painting by Leolux house artist Wouter Stips.

Leolux products are sold
all over the world.



Campaign image for the Guadalupe programme, 2016.

A focus on future generations

The third generation is now at the helm at Leolux. Sebastiaan Sanders, Jeroen's son, is developing a portfolio with multiple brands, each with its own position in the market. Leolux is investing in sustainable materials and production methods, in contemporary communications technology and in progressive online tools to inform consumers about the designs. The focus is on the future and the role that Leolux can play for future generations. Leolux presented an exploration of that future, during the

2019 Dutch Design Week; the Leolux What If Lab - a powerful vision of 2030 living.

Leolux has become an established name over the past 86 years. Innovation and change were constant drivers for that development. But they never compromise on certain things. Because every Leolux item of furniture is still made in Venlo (NL), on the banks of the river Maas, in a production location that is able to meet strict sustainable production requirements.



'Filter Family' presentation during the 2019 Dutch Design Week



A product of individuality

The world of Leolux offers space for every interior idea. From wonderful comfort furniture to individual signature pieces. You're in control; you determine which furniture we make to order for you. You select colours, materials and comfort options to shape the look of your new interior. And we're proud that we can offer you this ultimate service.



A form of temptation

Allow yourself to be tempted by the Rego's flowing Italian lines, or perhaps you prefer Flint's organic curves? Or is the iconic, progressive Pallone and Parabolica design or the decorative Caruzzo or Lloyd style more for you? Our collaboration with renowned international designers, each with their own specific style means you can always find a Leolux model to match your individual taste.

The most beautiful materials

Selecting your own colours and materials transforms your Leolux into a personal statement. Our luxury leather and fabric collection always have the colour and feel you're looking for. You can also select from many different materials, including wood, marble, glass and ceramics. And countless lacquer and epoxy colours, make it easy for you to put your personal stamp on a base or table top.

Create your own comfort

Comfort is the essence of Leolux furniture: the perfect support so you can enjoy the ultimate in comfortable seating. Most of our seating ideas can be adjusted to your personal requirements, including various options for seating height or cushion firmness. But you can also add a reclining mechanism to your armchair, or add an option so you can adjust your sofa arms whenever the mood takes you.

A crisp and clear image of your future Leolux

Each item of Leolux furniture is produced to order, so you can select your furniture colours and materials yourself. And that is of course a little stressful. Because what will your dream sofa, armchair, table or chair look like when it arrives? Leolux Creator is the solution. Design your own furniture and see how it will look in a crisp and clear image on your own computer or tablet.

Leolux Creator enables you to visualise almost every Leolux product. Select the configuration, upholstery and colours that appeal to you. You can then select your non-standard stitching or lacquered colour options. And of course, you can also configure our tables. You can change and improve as much as you want, until your Leolux is perfect. Find the Leolux Creator on the Leolux website: www.leolux.com/creator



The Leolux Creator: your self-styled furniture in razor sharp focus.

Select your own colours
and materials and transform
your Leolux into a personal
statement.



Explore the Leolux Design Centers

For specialised advice and inspiration, turn to the Leolux Design Centers. Here you can become familiar with all the possibilities the collection has to offer, free of any obligation. You will be received by experts who are driven by the desire to help you realise your own dreams for living. They provide advice about colours and materials, demonstrate the options and, if desired, use 3D drawings to bring your dream to life.

Our products are always sold via a specialised Leolux dealer who will be pleased to provide all the advice you require and is the point of contact for ordering and delivering your Leolux furniture. You can find an overview of our dealers on the website as well as the addresses and opening hours of our Leolux Design Centers.







Where hand-crafted art and innovative technology converge

A product of quality

You've made your choice and decided on every detail. Now it's the job that Leolux enjoys the most: producing your personal furniture. The form and comfort of the furniture you had in mind is realised in the expert hands of our carpenters, woodworkers, foam specialists, leather cutters, lacquer finishers and upholsterers.

Craftsmanship and innovation converge in the Leolux production locations in Venlo (NL) and Szolnok (H). For instance, a computer-controlled machine cuts the leather with millimetre precision but, of course, only after the leather has been inspected meticulously by our inspectors. And this is just one of the many examples.



The basis for comfort

Each item of furniture takes a journey through our factory. This journey starts in the woodworking, frame construction and preproduction departments, where the foundation for your comfort is created with great care. If you watch these processes, for instance during one of our factory tours, you'll discover that a Leolux is just as stunning on the inside as it is on the outside.

A feeling for upholstery

Your furniture then makes its way to the hall where we produce the upholstery. In the imposing leather warehouse, so many different high-quality leather types with endless variations in colour and feel await the moment that they are selected for your furniture. The Leolux leather masters already inspected whether the leather meets our strict requirements in the tannery, and there's another quality control on entrance to the warehouse. Irregularities such as scars are marked prior to cutting and are carefully avoided. Fabric upholstery is inspected carefully for flaws. Our fabric specialists also ensure that the fabric pile or pattern runs as beautifully as possible over the furniture.



In the hands of our craftsmen,
the furniture you have in mind
takes shape.



Final assembly

Once the upholstery has been cut to size, the fabric and leather sections arrive in the workshop, where they are stitched together to become furniture covers. In the meantime, metal and wooden components are lacquered or given a powder-coating in our lacquering department. The upholstery and all other components are assembled in the upholstery department. Our upholsterers use a subtle combination of strength and finesse to fit the furniture cover to your furniture. They ensure that every curve, seam and upholstery detail is perfect. And then to complete your furniture, our experts fit the base.

Delivered in style

The concluding phase ensures that your new Leolux finds its way to your interior in perfect condition. This starts with an extensive final inspection, after which the product is packaged with great care. The Logistics department and our drivers then ensure that your new pride and joy arrives on time at your desired location. And then the moment for which all our colleagues work hard every day arrives: the moment you start to enjoy your new Leolux.



Take a Leolux tour

We enjoy demonstrating our Leolux expertise and craftsmanship. You are always more than welcome to visit Via Creandi, the Leolux visitor center. During an extensive tour you can enjoy watching our furniture take shape in the expert hands of our craftsmen. The tour leader will inform you all about the work you see and how we organise our production. If you would like to take a Leolux tour, you can book one via our website.

Leolux Visitor Center
Marinus Dammeweg 22
Venlo (NL), nr. 6875
Tel.: +31 (0) 77 38 77 222
visitorcenter@leolux.nl

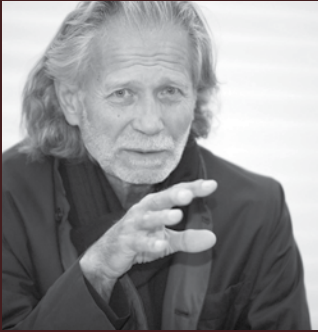

Jan Armgardt



Beck Design



Patrick Belli



Gino Carollo



Axel Enthoven



Cuno Frommherz

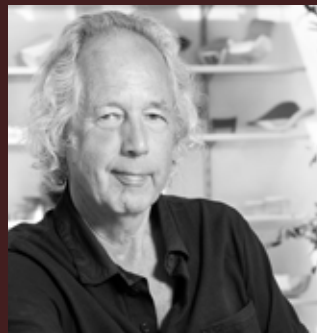

Stefan Heiliger



Hugo de Ruiter

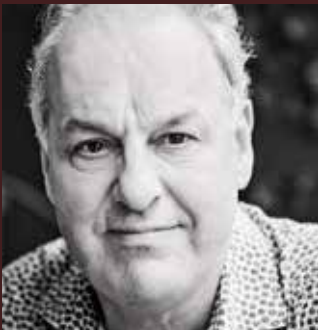

Frans Schrofer



Edward van Vliet



Christian Werner

Masters in form and function

Bringing people from all kinds of creative disciplines together is the real strength of Leolux. Craftsmen, product developers, artists, stylists and photographers, they all play a role. But the process begins in the mind of the freelance designer, the visionary who gives shape to his dreams about living.



Joel & Kate, Studio Truly Truly

Interview with Studio Truly Truly, the new Leolux art directors

Text: Jeroen Junte

Kate & Joel Booy, who together form design studio Truly Truly, are the new Leolux art directors. A perfect match, as they say themselves. “What Truly Truly and Leolux have in common is the pursuit of creativity.”

“Leolux is a courageous brand. It has a long history of original and daring designs with brilliant colours and expressive shapes. We want to build on this tradition”, stated Joel Booy (1981). He and partner Kate Booy (1981) do not only head up design studio Truly Truly, they are also the new Leolux art directors. “But times



Pavilion 'Das Haus' by Studio Truly Truly, commissioned by IMM Cologne, 2019.

“We take each other out of our comfort zones and create a surprising identity that you still recognise as a Leolux.”

are changing”, added Kate. “Not every item of furniture needs to be distinct. There’s now more space for nuance and detail.”

As Truly Truly, the Booy couple have created a furore over the past five years with understated furniture that captures your attention with its bright colours and sharp contours. Subtle details and intricate use of materials makes their designs much richer than they at first appear. “What Truly Truly has in common with Leolux is the pursuit of originality. Although our style is somewhat more reserved. But that’s great, because we take each other out of our comfort zones and create a surprising identity that you still recognise as a Leolux.”

Innovative living concept

The contact with Leolux came about after Truly Truly was asked to design Das Haus at the 2019 IMM furniture fair in Cologne. This prestigious assignment to present an innovative living concept made an impression on Leolux. “We designed everything ourselves for Das Haus; from the individual furniture, the staging and lighting to the folder, photography and even the bags. This was exactly what Leolux was seeking, an art director that considers every detail of the brand presentation as well as the collection.”

That is also exactly how Kate and Joel view their role as art directors. “We keep an eye on everything. Which new items of furniture are missing from the collection? What will the communications look like?” explained Kate. And yes, of course, they’ll also add their own designs to the collection. Joel: “After all, first and foremost, we are designers.” That Leolux has its own factory adds that extra something to their role as art directors. “Every new design, even an initial idea, can be tested immediately. Can it be made? If so, what will it cost?”

Graphic designers

This holistic approach can only succeed with unconditional trust. “That’s why we had countless discussions that were completely open. Sometimes we wanted to progress quickly. But at the same time Leolux challenged us to really make clear why we make certain choices”, stated Joel. What plays a

decisive role in this is that Leolux has been a family company for over seventy years. “The father of the current CEO positioned Leolux as a progressive brand in the 1990s. So, the desire to innovate is deeply embedded in the company.” Kate added: “Ultimately, as art directors we are never more than a link in a larger chain. Leolux is a family company and we’re now part of that family.”

Kate and Joel who with their young daughter also form a family, already had a career behind them when they relocated from the Australian city of Brisbane to Eindhoven in 2010. “We are both trained graphic designers and worked as colleagues at a design agency undertaking many assignments in the cultural sector. That offered us so much space for experimentation and expression”, explained Joel. “I wanted to study spatial design in depth. For me, there was just one place to do that: the Design Academy Eindhoven. I have a Dutch passport because my father is Dutch. That made the step a lot easier.” Kate quickly found work as graphic designer. “We started Truly Truly as soon as Joel graduated in 2014.”

Building stories

The Truly Truly portfolio is now diverse, from exclusive gallery pieces to commercial consumer furniture. “We’re inspired by combining artistic objects with a maximum level of sophistication and expression and products that are really practical, in which all aspects have been carefully considered to ensure accessibility for a large group of people”, stated Joel. Truly Truly still focuses on interiors. “Items of furniture are everyday objects and we have an intimate, physical connection with them. We sit or lie on them, feel them, even caress them. At the same time, with variations in form, material or colour an item of furniture can tell a range of stories.”

That is the core of Joel and Kate’s task as art directors: building the Leolux story. From photography for the catalogue to colours for the collection; nothing escapes their attention. “You could almost be forgiven for thinking that we have prepared ourselves for this particular job over the past ten years”, explained Joel. “It’s amazing that we can use all our knowledge and ideas in one assignment.”

A Leolux sofa is a great match for every contemporary interior - as a centre-piece or as a place to relax for the whole family. As comfort plays an important role in the Leolux philosophy, almost all Leolux designer sofas come with additional options: adjustable backs and seats, higher legs, or extra firm or extra soft foam. Select your own comfort, with colours and upholstery to match your requirements. A leather sofa or do you prefer a sofa upholstered in fabric? You can even choose the stitching colour from the extensive Leolux design collection.

Sofas

Overview Sofas



Adartne

Design: Natalie Buijs, 2007 / 2013

Inspiration – p. 36

Info – p. 179



Arabella

Design: Stefan Heiliger, 2011

Inspiration – p. 38

Info – p. 179



Bellice

Design: Beck Design, 2017

Inspiration – p. 40

Info – p. 180



Bora Balanza

Design: Axel Enthoven, 2016

Inspiration – p. 46

Info – p. 184



Bora Bora / Bora Bèta

Design: Axel Enthoven, 1983

Inspiration – p. 48

Info – p. 184



Devon

Design: Jan Armgardt, 2018

Inspiration – p. 50

Info – p. 185



Elias

Design: Christian Werner, 2018

Inspiration – p. 52

Info – p. 186



Flint

Design: Beck Design, 2019

Inspiration – p. 54

Info – p. 187



Guadalupe

Design: Christian Werner, 2016

Inspiration – p. 58

Info – p. 188



Gynko

Design: Jörg Wulff & Thomas Müller, 2014

Inspiration – p. 60

Info – p. 189



Mayon

Design: Christian Werner, 2012

Inspiration – p. 64

Info – p. 190



Nardo

Design: Beck Design, 2020

Inspiration – p. 66

Info – p. 190



Ponton Next

Design: Braun & Maniatis, 2008/2014

Inspiration – p. 68
Info – p. 191



Rego

Design: Gino Carollo, 2020

Inspiration – p. 70
Info – p. 192



Tango

Design: Jan Armgardt, 1984

Inspiration – p. 76
Info – p. 193



Vol de Rêve

Design: Jane Worthington, 2006

Inspiration – p. 77
Info – p. 193



Adartne

Design: Natalie Buijs, 2007 / 2013
More info - p. 179



Adartne

Design: Natalie Buijs, 2007 / 2013
More info - p. 179



Arabella

Design: Stefan Heiliger, 2011

More info – p. 179



Arabella

Design: Stefan Heiliger, 2011
More info - p. 179



Bellice

Design: Beck Design, 2017
More info - p. 180





Bellice

Design: Beck Design, 2017

More info – p. 180



Bellice

Design: Beck Design, 2017
More info – p. 180



Bellice

Design: Beck Design, 2017
More info – p. 180





Bora Balanza

Design: Axel Enthoven, 2016
More info – p. 184



50



Bora Bora / Bora Bèta

Design: Axel Enthoven, 1983
More info – p. 184





Devon

Design: Jan Armgardt, 2018
More info - p.185





Elias

Design: Christian Werner, 2018
More info – p. 186





Flint

Design: Beck Design, 2019
More info - p. 187



Flint

Design: Beck Design, 2019
More info - p. 187



Flint

Design: Beck Design, 2019
More info – p. 187



Flint

Design: Beck Design, 2019

More info – p. 187



Guadalupe

Design: Christian Werner, 2016
More info - p. 188



Guadalupe

Design: Christian Werner, 2016
More info - p. 188



Gynko

Design: Jörg Wulff & Thomas Müller, 2014
More info – p. 189





Gynko

Design: Jörg Wulff & Thomas Müller, 2014
More info – p. 189

Sofas



Gynko

Design: Jörg Wulff & Thomas Müller, 2014
More info – p. 189



Mayon

Design: Christian Werner, 2012
More info – p. 190



Mayon

Design: Christian Werner, 2012

More info - p. 190



Nardo

Design: Beck Design, 2020
More info – p. 190





Nardo

Design: Beck Design, 2020

More info - p. 190



Ponton Next

Design: Braun & Maniatis, 2008/2014
More info – p. 191





Rego

Design: Gino Carollo, 2020
More info - p. 192





Rego

Design: Gino Carollo, 2020
More info – p. 192



Rego

Design: Gino Carollo, 2020

More info - p. 192



Rego

Design: Gino Carollo, 2020
More info - p. 192

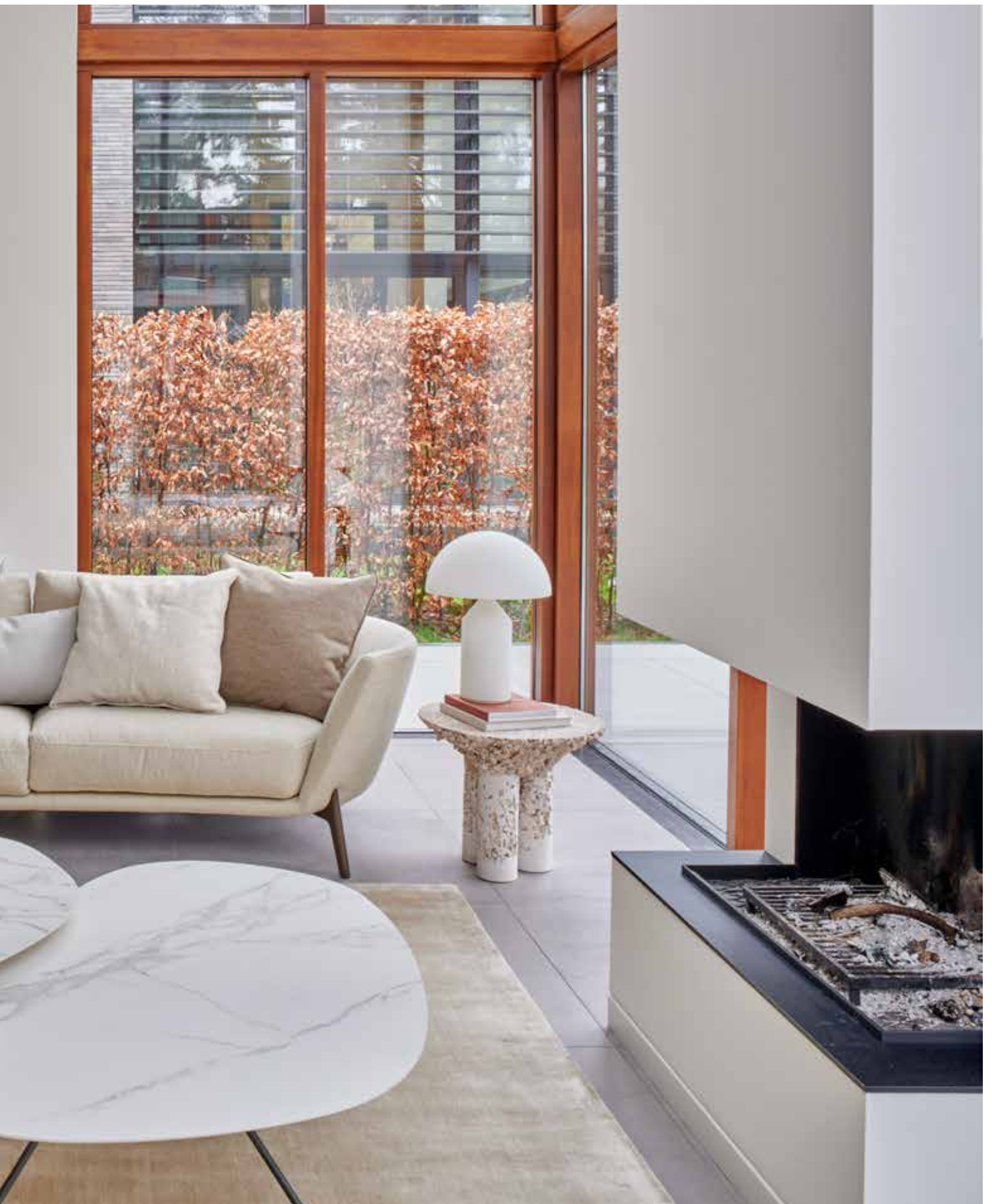



Tango

Design: Jan Armgardt, 1984
More info – p. 193



Vol de Rêve

Design: Jane Worthington, 2006
More info – p. 193

An iconic element for your living room or a functional item of furniture that matches your seating area? Leolux armchairs come in all shapes and sizes. From expressive to subtle. And almost all are fitted with functions to make sitting even more comfortable. Even if you are somewhat taller or shorter than average.

Armchairs

Overview armchairs



Cantate
Design: Frans Schrofer, 2017

Inspiration – p. 82
Info – p. 194



Caruzzo
Design: Frans Schrofer, 2015

Inspiration – p. 84
Info – p. 194



Darius
Design: Jan Armgardt, 2013

Inspiration – p. 88
Info – p. 195



Dolcinea
Design: Jan Armgardt, 1992

Inspiration – p. 89
Info – p. 195



Hilco
Design: Patrick Belli, 2019

Inspiration – p. 90
Info – p. 196



Indra
Design: Cuno Frommherz, 2015

Inspiration – p. 91
Info – p. 196



Jill
Design: Edward van Vliet, 2018

Inspiration – p. 92
Info – p. 197



Kikko
Design: Hugo de Ruiter, 2000

Inspiration – p. 93
Info – p. 197



Lloyd
Design: Gino Carollo, 2018

Inspiration – p. 94
Info – p. 198



Mayuro
Design: Christian Werner, 2013

Inspiration – p. 95
Info – p. 198



Pallone
Design: Boonzaaijer / Mazairac / de Scheemaker, 1989

Inspiration – p. 96
Info – p. 199



Papageno
Design: Jan Armgardt, 1993

Inspiration – p. 98
Info – p. 199

**Parabolica**

Design: Stefan Heiliger, 2009

Inspiration – p. 100

Info – p. 200

**Scylla**

Design: Gerard Vollenbrock, 1996

Inspiration – p. 102

Info – p. 200

**Volare**

Design: Jan Armgardt, 1998

Inspiration – p. 104

Info – p. 201



Cantate

Design: Frans Schrofer, 2017
More info - p. 194



Cantate

Design: Frans Schrofer, 2017
More info – p. 194



Caruzzo

Design: Frans Schrofer, 2015
More info - p. 194



Caruzzo

Design: Frans Schrofer, 2015
More info - p. 194



Caruzzo

Design: Frans Schrofer, 2015
More info - p. 194





Caruzzo

Design: Frans Schrofer, 2015
More info - p. 194



Darius

Design: Jan Armgardt, 2013
More info – p. 195



Dolcinea

Design: Jan Armgardt, 1992
More info – p. 195



Dolcinea

Design: Jan Armgardt, 1992
More info – p. 195



Hilco

Design: Patrick Belli, 2019

More info – p. 196



Indra

Design: Cuno Frommherz, 2015
More info - p. 196



Jill

Design: Edward van Vliet, 2018
More info – p. 197



Kikko

Design: Hugo de Ruiter, 2000

More info – p. 197



Lloyd

Design: Gino Carollo, 2018

More info - p. 198

Armchairs



Mayuro

Design: Christian Werner, 2013
More info – p. 198



Mayuro

Design: Christian Werner, 2013
More info – p. 198



Pallone

Design: Boonzaaijer / Mazairac / de Scheemaker, 1989

More info – p. 199



Pallone

Design: Boonzaaijer / Mazairac / de Scheemaker, 1989
More info – p. 199



Papageno

Design: Jan Armgardt, 1993

More info – p. 199



Papageno

Design: Jan Armgardt, 1993
More info – p. 199



Parabolica

Design: Stefan Heiliger, 2009
More info – p. 200



Parabolica

Design: Stefan Heiliger, 2009
More info – p. 200



Scylla

Design: Gerard Vollenbrock, 1996

More info – p. 200



Scylla

Design: Gerard Vollenbroek, 1996
More info - p. 200



Volare

Design: Jan Armgardt, 1998
More info – p. 201



Volare

Design: Jan Armgardt, 1998
More info – p. 201

Sitting should always be comfortable. This, of course, applies to the furniture in your living room, but also when seated at the table you deserve the comfort of a real Leolux. From a wonderful dining-room chair with armrests to a stylish chair for hours of comfortable lingering at the table; you're guaranteed to succeed with our tasteful collection of dining-room chairs.

Chairs



Callas

Design: Frans Schrofer, 2015

Inspiration – p. 110
Info – p. 202



Caron

Design: Frans Schrofer, 2018

Inspiration – p. 112
Info – p. 202



Ditte / Didore

Design: Cuno Frommherz, 2017

Inspiration – p. 113
Info – p. 202



Freyr

Design: Erik Munnikhof, 2003

Inspiration – p. 114
Info – p. 203



Mara

Design: Christian Werner, 2016

Inspiration – p. 115
Info – p. 203



Mime

Design: Gino Carollo, 2019

Inspiration – p. 116
Info – p. 203



Talos

Design: Scooter & Partners, 2006

Inspiration – p. 118
Info – p. 204



Tamarinde

Design: Frans Schrofer, 2013

Inspiration – p. 120
Info – p. 204



Callas

Design: Frans Schrofer, 2015

More info – p. 202



Callas

Design: Frans Schrofer, 2015
More info - p. 202



Caron

Design: Frans Schrofer, 2018
More info – p. 202



Ditte

Design: Cuno Frommherz, 2017
More info – p. 202



Didore

Design: Cuno Frommherz, 2017
More info – p. 202



Freyr

Design: Erik Munnikhof, 2003
More info – p. 203

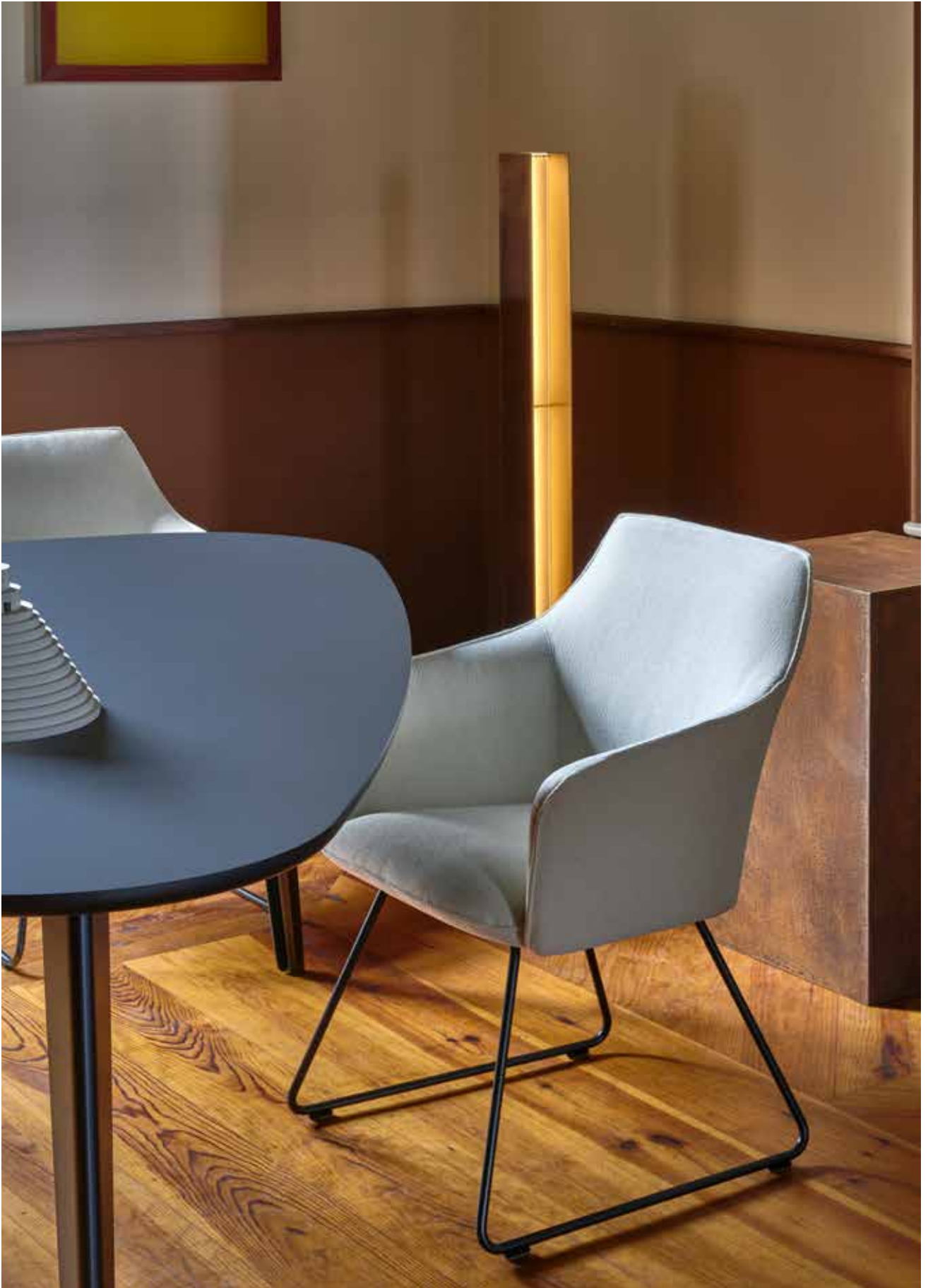

Mara

Design: Christian Werner, 2016

More info – p. 203



Mime

Design: Gino Carollo, 2019
More info - p. 203



Mime

Design: Gino Carollo, 2019
More info - p. 203



Talos

Design: Scooter & Partners, 2006

More info – p. 204



Talos

Design: Scooter & Partners, 2006
More info - p. 204



Tamarinde

Design: Frans Schrofer, 2013
More info – p. 204



Tamarinde

Design: Frans Schrofer, 2013
More info – p. 204

With a table you envision a central meeting place. A place for a delicious meal with friends, great conversation or quality time with a book or magazine. And you're entirely right in this. But a table can of course also be a handy side-table or a stylish coffee table. Whatever type of table you're looking for, you're in the right place with Leolux. You are very welcome to join us!

Tables

Overview coffee tables



Aditi
Design: Minimal Design, 2002

Inspiration – p. 126
Info – p. 205



Cimber
Design: Frans Schrofer, 2012

Inspiration – p. 127
Info – p. 205



Coda
Design: Pascal Bosetti, 2018

Inspiration – p. 128
Info – p. 205



Griffo
Design: Scooter & Partners, 2015

Inspiration – p. 130
Info – p. 206



Iduna
Design: Beck Design, 2017

Inspiration – p. 131
Info – p. 206



Liliom
Design: Beck Design, 2010

Inspiration – p. 132
Info – p. 207



Lys
Design: Beck Design, 2018

Inspiration – p. 134
Info – p. 207



Ninfea
Design: Stephan Veit, 2015

Inspiration – p. 135
Info – p. 208



Portello
Design: Patrick Belli, 2013

Inspiration – p. 137
Info – p. 208



Prismo
Design: Edward van Vliet, 2017

Inspiration – p. 138
Info – p. 209



Rolan
Design: Gino Carollo, 2020

Inspiration – p. 140
Info – p. 209



Tampa
Design: Beck Design, 2019

Inspiration – p. 142
Info – p. 209



Bondi

Design: A Design Studio, 2019

Inspiration – p. 144

Info – p. 210



Columna

Design: Hugo de Ruiter, 2016

Inspiration – p. 146

Info – p. 210



Kalia

Design: A Design Studio, 2012

Inspiration – p. 148

Info – p. 211



Yama

Design: A Design Studio, 2017

Inspiration – p. 150

Info – p. 211



Aditi

Design: Minimal Design, 2002

More info – p. 205



Cimber

Design: Frans Schrofer, 2012
More info – p. 205



Coda

Design: Pascal Bosetti, 2018

More info – p. 205



Coda

Design: Pascal Bosetti, 2018
More info - p. 205



Griffo

Design: Scooter & Partners, 2015
More info – p. 206



Iduna

Design: Beck Design, 2017
More info – p.206



Liliom

Design: Beck Design, 2010
More info – p. 207

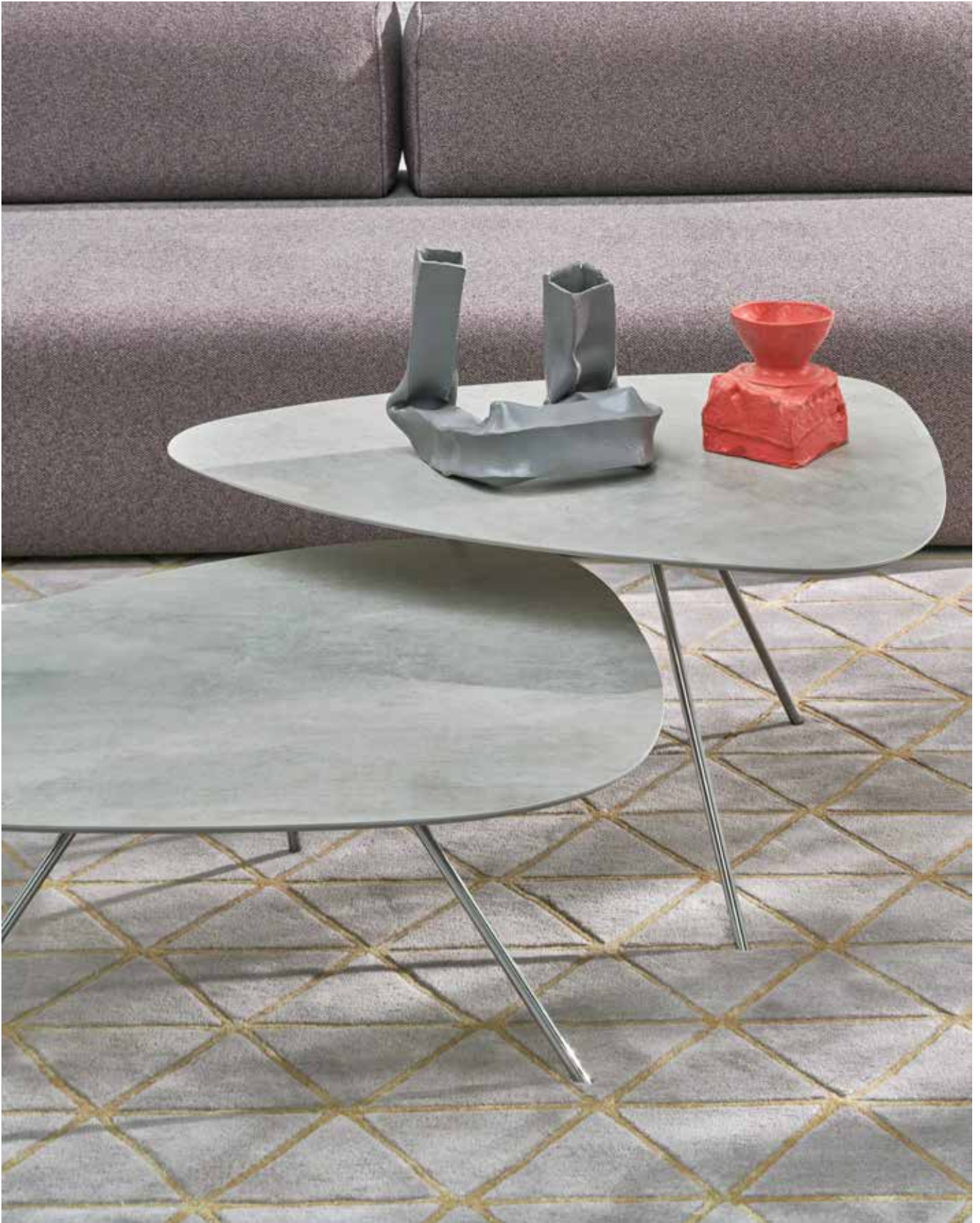

Liliom

Design: Beck Design, 2010

More info - p. 207



Lys

Design: Beck Design, 2018
More info – p.207



Ninfea

Design: Stephan Veit, 2015
More info – p. 208



Ninfea

Design: Stephan Veit, 2015
More info – p. 208



Portello

Design: Patrick Belli, 2013

More info - p. 208



Prismo

Design: Edward van Vliet, 2017
More info - p. 209



Prismo

Design: Edward van Vliet, 2017

More info – p. 209



Rolan

Design: Gino Carollo, 2020
More info - p. 209



Rolan

Design: Gino Carollo, 2020
More info - p. 209



Tampa

Design: Beck Design, 2019
More info – p. 209



Tampa

Design: Beck Design, 2019
More info – p. 209





Bondi

Design: A Design Studio, 2019

More info - p. 210



Bondi

Design: A Design Studio, 2019
More info - p. 210



Columna

Design: Hugo de Ruiter, 2016
More info – p. 210

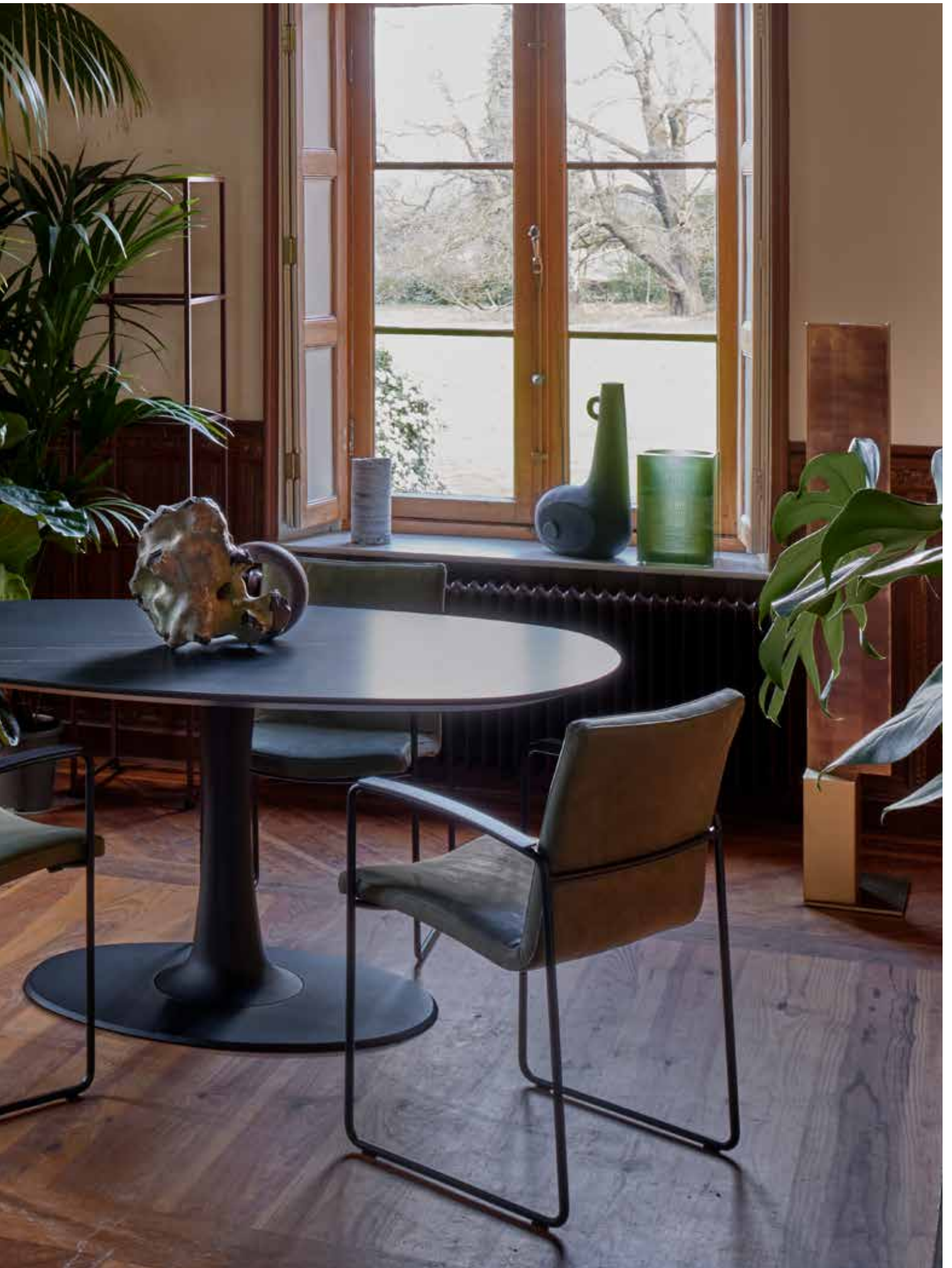

Kalia

Design: A Design Studio, 2012
More info – p. 211







Yama

Design: A Design Studio, 2017
More info – p. 211





Yama

Design: A Design Studio, 2017

More info - p. 211

Each interior is a composition. A totality of elements, large and small, that together determine the ambiance. Your ambiance. For a sublime total look, Leolux offers you a wide selection of the most beautiful accessories. Create a beautiful basis with a high-quality rug and add the finishing touches with a stylish decorative cushion or nice plaid. Your interior only really feels complete with Leolux accessories.

Accessories

Overview Accessories



Cosy Cushions

Design: Leolux, 2013

Inspiration – p. 156

Info – p. 212



Cushion Lusso

Design: Scooter & Partners, 2018

Inspiration – p. 157

Info – p. 212



Polaris

Design: Edward van Vliet, 2017

Inspiration – p. 158

Info – p. 213



Polaris Plaid

Design: Edward van Vliet, 2017

Inspiration – p. 158

Info – p. 213



Sashiko

Design: Edward van Vliet, 2017

Inspiration – p. 159

Info – p. 213



Sashiko Plaid

Design: Edward van Vliet, 2017

Inspiration – p. 159

Info – p. 213



Topsy Turvy

Design: Edward van Vliet, 2017

Inspiration – p. 160

Info – p. 214



Amund

Design: Maghalie Dooms, 2020

Inspiration – p. 161

Info – p. 214



Girisha

Design: Edward van Vliet, 2017

Inspiration – p. 162

Info – p. 215



Izem

Design: Edward van Vliet, 2017

Inspiration – p. 162

Info – p. 215

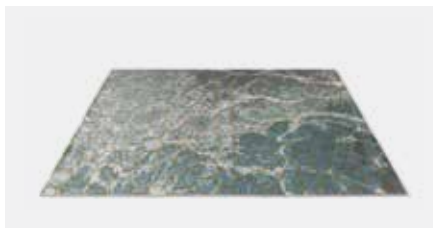

Mizu

Design: Edward van Vliet, 2018

Inspiration – p. 163

Info – p. 216



Patna

Design: Leolux, 2018

Inspiration – p. 164

Info – p. 216



Sperto

Design: Maghalie Dooms, 2020

Inspiration – p. 164
Info – p. 217



Amulet

Design: Edward van Vliet, 2017

Inspiration – p. 165
Info – p. 218



Capri

Design: Edward van Vliet, 2018

Inspiration – p. 165
Info – p. 218



Funo

Design: Michael Raasch, 2020

Inspiration – p. 166
Info – p. 219

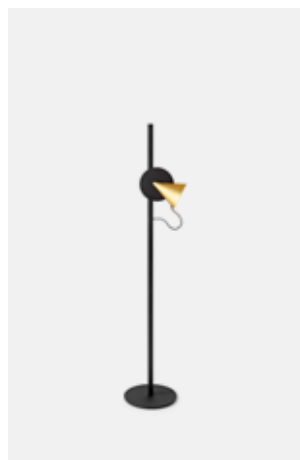

Qone

Design: Michael Raasch, 2020

Inspiration – p. 166
Info – p. 219



Cosy Cushions

Design: Leolux, 2013
More info – p. 212



Cosy Cushions

Design: Leolux, 2013
More info - p. 212



Cushion Lusso

Design: Scooter & Partners, 2018
More info - p. 212



Polaris

Design: Edward van Vliet, 2017
More info – p. 213



Polaris Plaid

Design: Edward van Vliet, 2017
More info – p. 213



Sashiko Plaid

Design: Edward van Vliet, 2017

More info – p. 213



Sashiko

Design: Edward van Vliet, 2017

More info – p. 213



Topsy Turvy

Design: Edward van Vliet, 2017

More info – p. 214

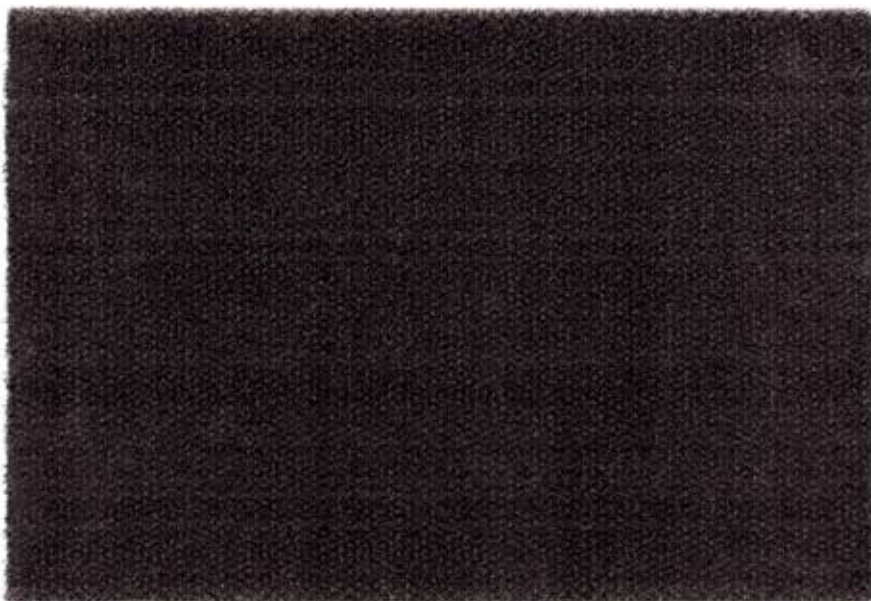

Amund

Design: Maghalie Doods, 2020

More info – p. 214



Amund

Design: Maghalie Doods, 2020

More info – p. 214

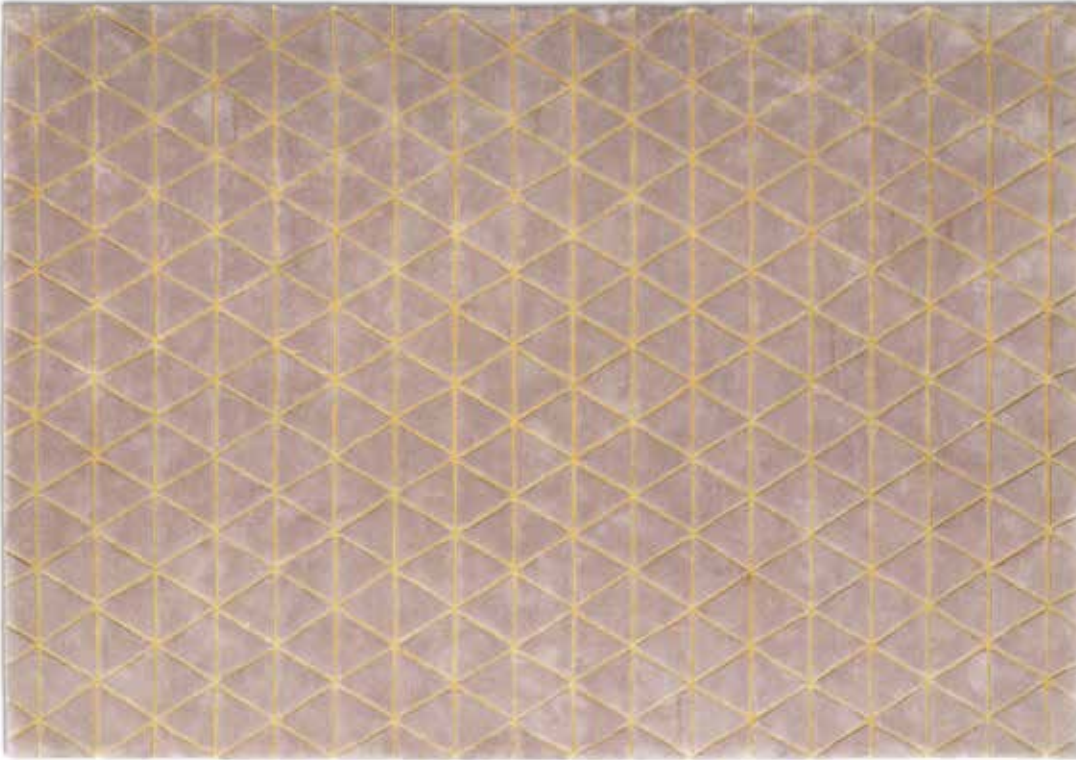

Girisha

Design: Edward van Vliet, 2018

More info - p. 215



Izem

Design: Edward van Vliet, 2017

More info - p. 215

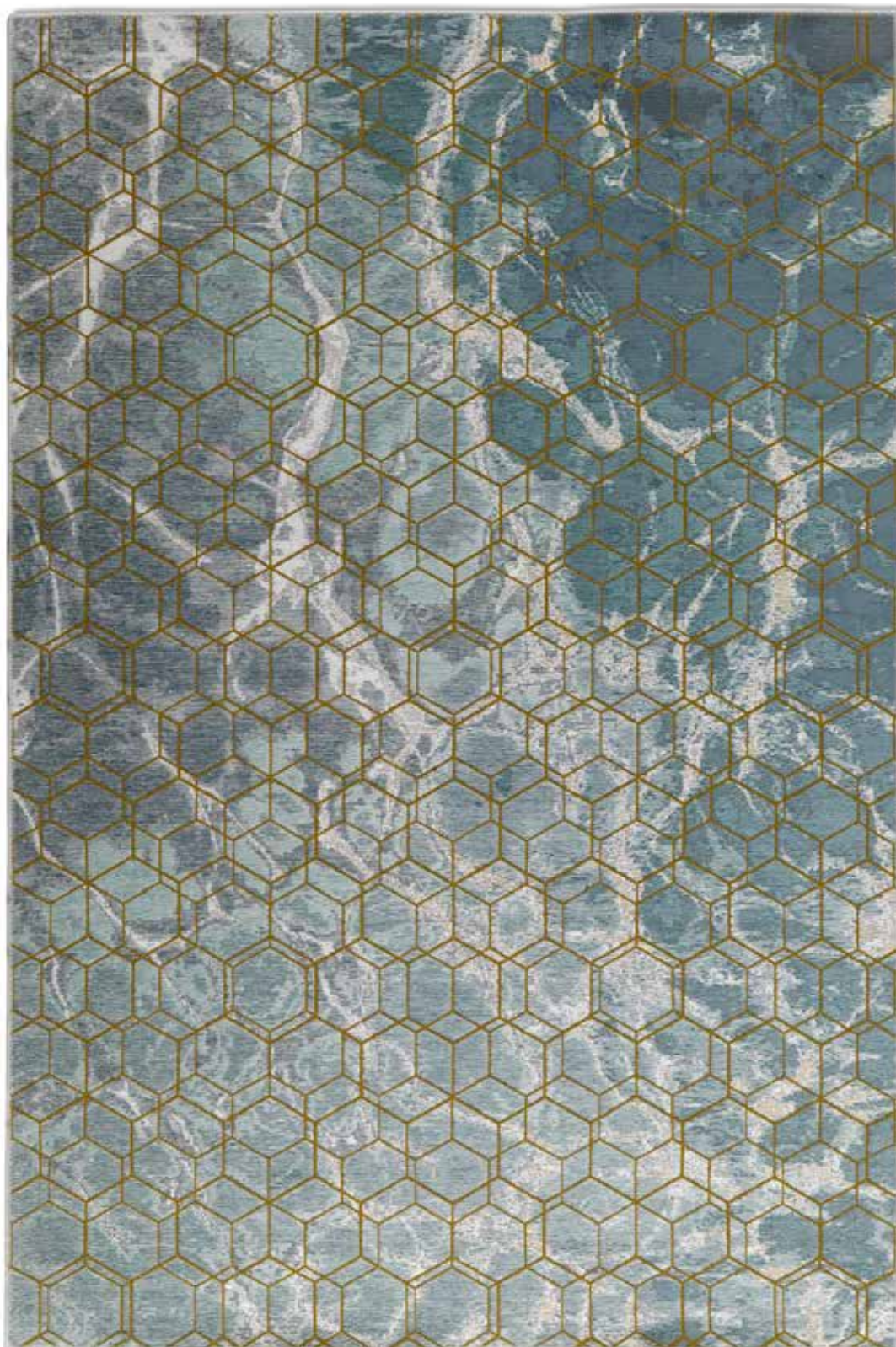

Mizu

Design: Edward van Vliet, 2018

More info – p. 216



Patna

Design: Leolux, 2018
More info – p. 216



Sperto

Design: Maghalie Doods, 2020
More info – p. 217



Amulet

Design: Edward van Vliet, 2017
More info – p. 218



Capri

Design: Edward van Vliet, 2018
More info – p. 218



Funo

Design: Michael Raasch, 2020
More info – p. 219



Qone

Design: Michael Raasch, 2020
More info – p. 219



Adartne

Design: Natalie Buijs, 2007 / 2013

Sofa – p. 36
Info – p. 179



Amulet

Design: Edward van Vliet, 2017

Info – p. 218



Bellice

Design: Beck Design, 2017

Sofa – p. 40
Info – p. 180



Bora Balanza

Design: Axel Enthoven, 2016

Sofa – p. 46
Info – p. 184



Bora-Bora / Bora-Bèta

Design: Axel Enthoven, 1983

Sofa – p. 48
Info – p. 184



Cantate

Design: Frans Schrofer, 2017

Armchair – p. 82
Info – p. 194



Capri

Design: Edward van Vliet, 2018

Info – p. 218



Caruzzo (Forte)

Design: Frans Schrofer, 2015

Armchair – p. 84
Info – p. 194



Caruzzo (Fine)

Design: Frans Schrofer, 2015

Armchair – p. 84
Info – p. 194



Darius

Design: Jan Armgardt, 2013

Armchair – p. 88
Info – p. 195



Devon

Design: Jan Armgardt, 2018

Sofa – p. 50
Info – p. 185



Elias

Design: Christian Werner, 2018

Sofa – p. 52
Info – p. 186



Flint
Design: Beck Design, 2019

Sofa – p. 54
Info – p. 187



Guadalupe
Design: Axel Enthoven, 1983

Sofa – p. 58
Info – p. 188



Gynko
Design: Jörg Wulff & Thomas Müller, 2014

Sofa – p. 60
Info – p. 189



Hilco
Design: Patrick Belli, 2019

Armchair – p. 90
Info – p. 196



Indra
Design: Cuno Frommherz, 2015

Armchair – p. 91
Info – p. 196



Jill
Design: Edward van Vliet, 2018

Armchair – p. 92
Info – p. 197



Lloyd
Design: Gino Carollo, 2018

Armchair – p. 94
Info – p. 198



Mayon
Design: Christian Werner, 2012

Sofa – p. 64
Info – p. 190



Mayuro
Design: Christian Werner, 2013

Armchair – p. 95
Info – p. 198



Nardo
Design: Beck Design, 2020

Sofa – p. 66
Info – p. 190

**Pallone**

Design: Boonzaaijer / Mazairac /
De Scheemaker, 1989

Armchair – p. 96
Info – p. 199

**Ponton Next**

Design: Braun & Maniatis, 2008/2014

Sofa – p. 68
Info – p. 191

**Rego**

Design: Gino Carollo, 2020

Sofa – p. 70
Info – p. 192

**Rego**

Design: Gino Carollo, 2020

Sofa – p. 70
Info – p. 192

**Scylla**

Design: Gerard Vollenbrock, 1996

Armchair – p. 102
Info – p. 200

**Volare**

Design: Jan Armgardt, 1998

Armchair – p. 104
Info – p. 201

**Vol de Rêve**

Design: Jane Worthington, 2006

Sofa – p. 77
Info – p. 193

A Leolux is all about feeling. It's about the look that conquers your heart and the comfort that always supports you. But you also know that every product that leaves our factory is a unique one. That is why we would like to give you an overview of the facts and possibilities to make your furniture personal.

Product information

Index

- 180 Your Leolux in the best condition
- 182 Service and warranty

Sofas

- 179 Adartne
- 179 Arabella
- 180 Bellice
- 184 Bora Balanza
- 184 Bora Bora / Bora Bèta
- 185 Devon
- 186 Elias
- 187 Flint
- 188 Guadalupe
- 189 Gynko
- 190 Mayon
- 190 Nardo
- 191 Ponton Next
- 192 Rego
- 193 Tango
- 193 Vol de Rêve

Armchairs

- 194 Cantate
- 194 Caruzzo
- 195 Darius
- 195 Dolcinea
- 196 Hilco
- 196 Indra
- 197 Jill
- 197 Kikko
- 198 Lloyd
- 198 Mayuro
- 199 Pallone
- 199 Papageno
- 200 Parabolica
- 200 Scylla
- 201 Volare

Chairs

- 202 Callas
- 202 Caron
- 202 Ditte and Didore
- 203 Freyr
- 203 Mara
- 203 Mime
- 204 Talos
- 204 Tamarinde

Coffee tables / Occasional tables

- 205 Aditi
- 205 Cimber
- 205 Coda
- 206 Griffo
- 206 Iduna
- 207 Liliom
- 207 Lys
- 208 Ninfea
- 208 Portello
- 209 Prismo
- 209 Rolan
- 209 Tampa / Troy

Tables

- 210 Bondi
- 210 Columna
- 211 Kalia
- 211 Yama

Accessories

- 212 Cosy Cushions
- 212 Cushion Lusso
- 213 Polaris
- 213 Sashiko
- 214 Topsy Turvy
- 214 Amund
- 215 Girisha
- 215 Izem
- 216 Mizu
- 216 Patna
- 217 Sperto
- 218 Amulet
- 218 Capri
- 219 Funo
- 219 Qone

- 220 The most stunning materials
- 232 Leolux Design Centers

Icons



Lower

This model is available with lower feet or armrests.



Higher

This model is available with higher feet or armrests.



Shorter seat depth

Available with a shorter seat, or fitted with an adjustable seat. Ideal for smaller users.



Longer seat depth

Available with a longer seat, or fitted with an adjustable seat. Ideal for bigger users.



Tilt

Armchair with a mechanism that enables you to adjust the tilt of the entire seat, forwards or backwards.



Adjustable backrest

The backrest can be adjusted as required—you can choose for a “lazier” or more upright position.



Swivel

Armchair with a mechanism that enables you to swivel the seat.



Adjustable arm and/or back parts

This model can be adapted to the mood of the moment by adjusting the arms or parts of the backrest.



Castors

Available with castors which enable you to move this seating concept around with even more ease.



Pocket-spring

Available with pocket-spring cushions.



Extendable table

This table is fitted with a system with which you can make it bigger or smaller.



Leather

This product is available in leather.



Fabric

This product is available in fabrics.



Lacquer

This product is available in various Leolux lacquer, stain or epoxy colours.



Your Leolux in the best condition

Our craftsmen incorporate the most beautiful and best materials in your own item of furniture. That's why our products have a long lifespan.

But with a little maintenance, you can keep your Leolux in even better condition. Of course, we'd like to tell you how best to do this. That's why our website contains maintenance instructions for all materials that we use. Check www.leolux.com to keep your sofa, armchair, table or rug in the very best condition!



Service and warranty

Leolux strives to provide you with a perfect product. Even so, something can always go wrong. After all, the making of a piece of Leolux furniture remains a human activity. If something is not in order, we will correct it for you. And if something goes wrong at a later date, then the Leolux warranty provides reassurance.

If you experience a problem, your dealer is the first person to contact, however, you can also contact Leolux directly. You can contact our service department via the Leolux website. There you will find our complete warranty scheme, useful maintenance tips and the serviceshop, where you can quickly and easily purchase small parts and maintenance products.

**More information about service and maintenance:
www.leolux.com/service-maintenance**

180

Adartne

Inspiration – p. 36

Design: Natalie Buijs, 2007 / 2013

In fabric or leather, Adartne exudes atmosphere and colour in every room. And the transparent look of the frame makes this Natalie Buijs design a great choice for smaller living rooms. With clear lines and ample choices for the upholstery, frame and the cheerful decorative seam 'Dashes'. Combine the colours to decide your ultimate personal styling mix. Expressive or more understated.

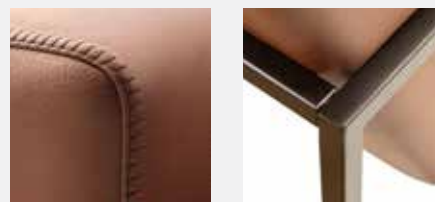
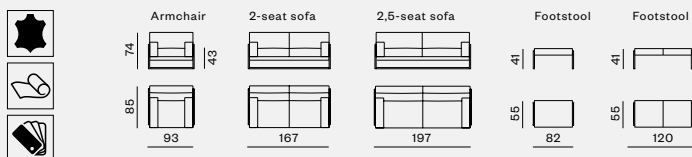

Arabella

Inspiration – p. 38

Design: Stefan Heiliger, 2011

Admiring looks follow the Arabella lines, which in dual colours become even more exciting. The asymmetrical shape is a voyage of discovery in itself. But above all, as Arabella supports so many different seating positions, it is a truly functional piece. It's not without reason that this comfortable Stefan Heiliger showpiece has been awarded the: 2011 Good Industrial Design award, 2012 Interior Innovation Award and the 2012 Good Design Award.

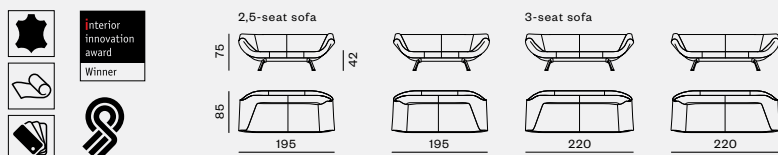

Bellice

Inspiration – p. 42

Design: Beck Design, 2017

A real beauty, opulent and inviting. Bellice brings together taste, atmosphere and living styles thanks to the extensive range of options and timeless refinement of its finishing. You can see this in the hand-knotted decorative stitching and the loosely upholstered cushions, and you can feel it in the comfort.

The Bellice range is unique in terms of its possibilities. You can define the dimensions, comfort and versions exactly as you want them, so that they fit in every interior. Your own individual style determines the shape that Bellice takes.



Cushion width

Your Bellice starts with the seat width. This is the first decision you need to make before you choose the legs, arms, upholstery materials or colours. Bellice is available as an armchair, or as a sofa with two 70, 80, 90, 100, or 110 centimetre cushions. Virtually all these widths are also available for the modular elements. There are also the XL sofas sized 3 x 80 or 3 x 90 centimetres.

Comfort

Some people prefer a firm comfort; others love a soft comfort. Nothing is more personal than seating comfort. So when you buy a Bellice, you can choose from different levels of comfort for both the seats and the back cushions.



Soft

For a soft and comfortable sitting experience, the seat or back is filled with foam covered with a wadding made from 90% duck feathers.

Medium

For a firmer seat, the medium comfort level has a foam core, supplemented with high-quality flock filling.

Semi-firm

With the option Semi-firm, you choose a filling that consists entirely of HR-foam. These cushions are tightly upholstered.

Firm

For a firm and tightly upholstered seat, choose this option. It has a filling of HR-foam with a higher density, making it the firmest of all comfort styles.

All upholstery will develop creases over time.

However, these creases are kept to a minimum in shape-stable cushions

Arms

It may seem a mere detail, but when you see the different versions, you suddenly realise how much an arm changes the appearance of your sofa. So with the Bellice, you can choose from no fewer than five arm types: narrow-low, narrow-high, wide-low, wide-high and narrow-adjustable.



Narrow-low



Narrow-high



Wide-low



Wide-high



Narrow-adjustable

Base

Six different base options are available for the Bellice. You have plenty of choice, from sleek to decorative; every leg or sledge base will give your sofa a different look. The Fino and Sobrio legs, the stainless steel Tubo legs and the Anillo sledge base can be optionally lacquered or powder coated (epoxy). You can have the Palo wooden leg stained or oiled. Finally, there is the Onyx leg; it is available in epoxy or lacquer and is the only leg available in the beautiful Black Nickel.

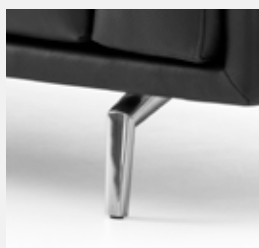

Fino



Sobrio

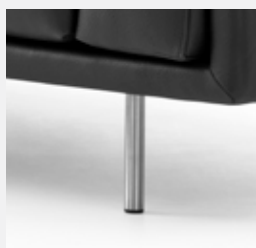

Tubo



Palo

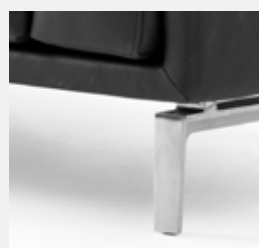

Anillo



Onyx

Bellice

Design: Beck Design, 2017

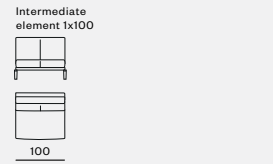
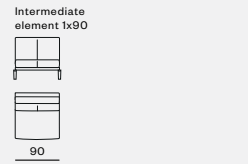
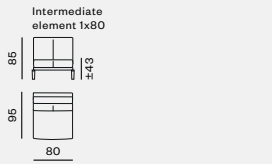
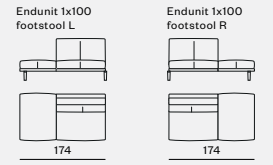
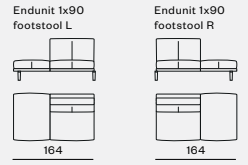
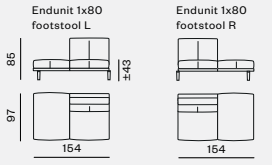
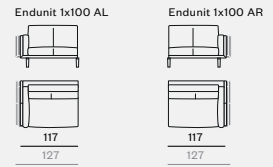
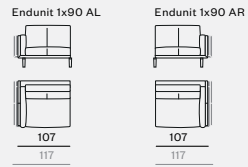
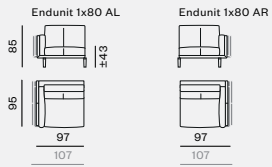
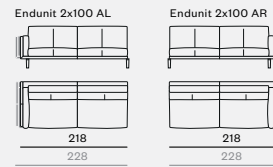
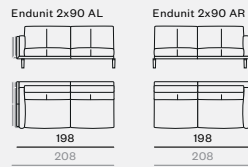
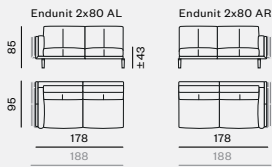
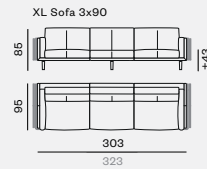
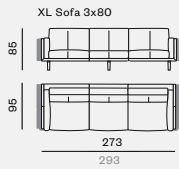
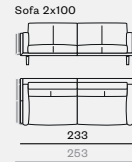
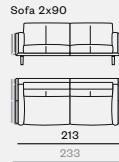
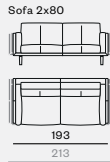
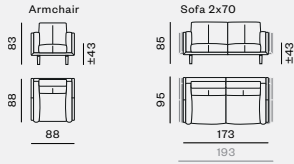

Bellice

Design: Beck Design, 2017

Sofa 2x110

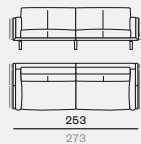

Corner element XL

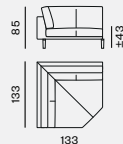

Corner element 100 SBL

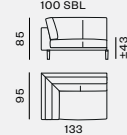

Corner element 100 SBR



Corner element 110 SBL



Corner element 110 SBR



Long Chair 1x110 footstool L

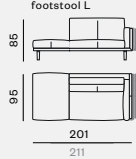

Long Chair 1x110 footstool R

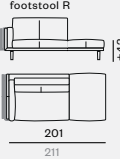

Chaise longue 1x90 AL

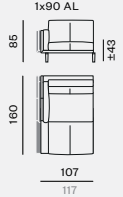

Chaise longue 1x90 AR



Chaise longue 1x125 AL

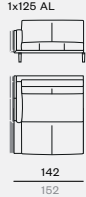

Chaise longue 1x125 AR



Endunit 2x110 AL

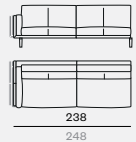

Endunit 2x110 AR

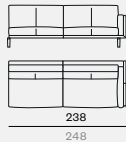

Connection element 100 AR

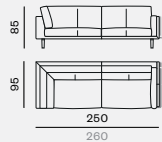

Connection element 100 AL

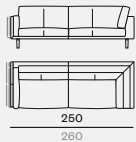

Connection element 110 AR

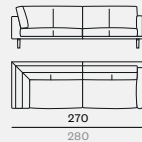

Connection element 110 AL

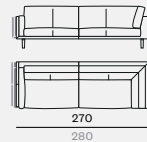

Endunit 1x110 AL



Endunit 1x110 AR



Footstool 80x57



Footstool 100x57



Footstool 120x57



Footstool 97x97



Connection footstool 1x100

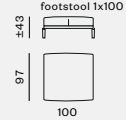

Endfootstool R 1x100



Endfootstool L 1x100



Endunit 1x110 footstool L



Endunit 1x110 footstool R



Insert table 80

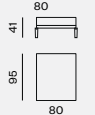

End table 80 R



End table 80 L



Insert table 55

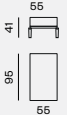

End table 55 R



End table 55 L



Intermediate element 1x110



Headrest 50 cm



Headrest 60 cm



Headrest 80 cm



Cushion with bolster

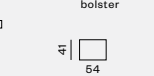

Examples

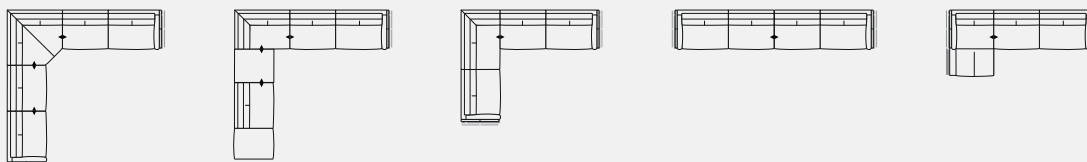

Bora Balanza

Inspiration – p. 48

Design: Axel Enthoven, 2016

The connoisseur will immediately recognise that the inspiration for Bora Balanza is derived from the successful 1980s-era Bora series. However, designer Axel Enthoven used a completely new approach to the basic principle of comfort and hidden beauty, entirely in keeping with these times. The result is both comfortable and beautiful. A reborn Bora, in total balance.

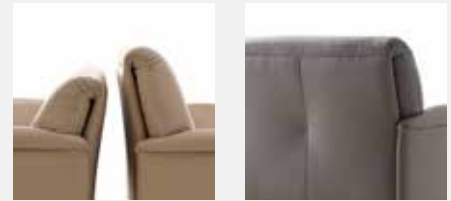
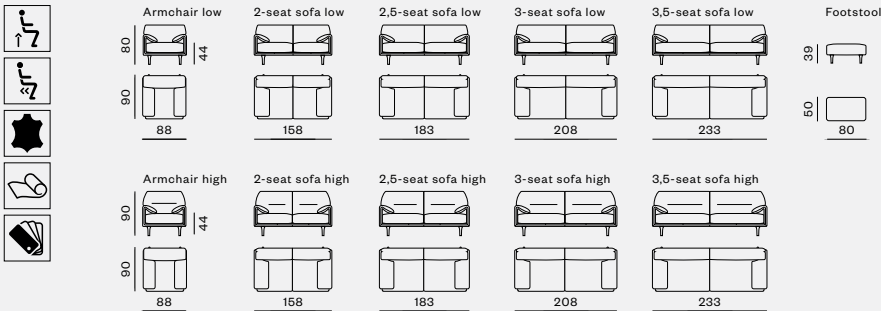

Bora Bora / Bora Bèta

Inspiration – p. 50

Design: Axel Enthoven, 1983

The Boras were truly revolutionary at the time. The design was so light and subtle, it was simply unparalleled. Axel Enthoven created an interplay between forms, on which time has no influence. Bora Bora and the higher Bèta version are unchanged classics, with the soft arms and backs that mould themselves to your body offering extremely high comfort levels.

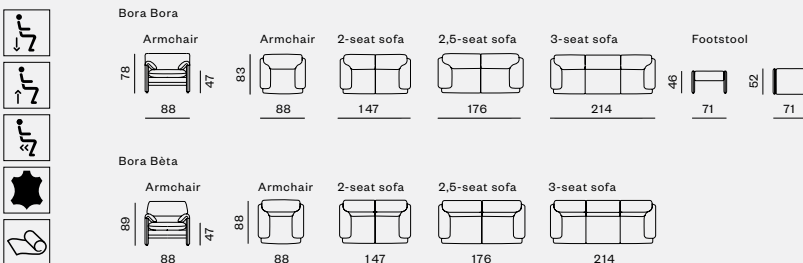

Devon

Inspiration – p. 52

Design: Jan Armgardt, 2018

This sofa programme combines the design quality of Jan Armgardt with renowned Leolux craftsmanship. From an individual sofa or chaise longue to a generous modular set. Whatever you choose, every Devon version offers adjustability for creating the ultimate in comfort. The beautiful crafted details ensure that Devon is immediately recognisable as a true Leolux sofa, but with its own unique look.

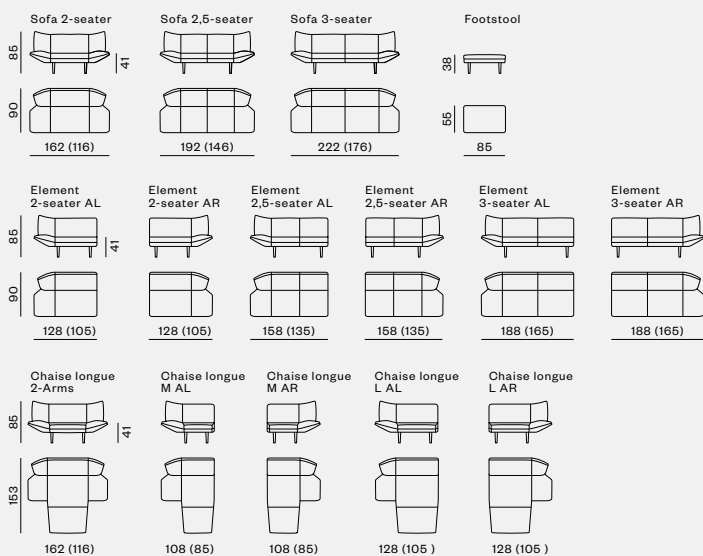

Elias

Inspiration – p. 54

Design: Christian Werner, 2018

A lovely, deep sofa with undulating lines and large surfaces. The arms flow over into the back, ensuring that Elias looks low and light, an image enhanced by unexpected design delights, such as the decorative seam on the arms and the slender legs that support the sofa. Although the deep seat is very comfortable in its pure shape, this sofa offers extra comfort with the two separate cushions that follow the curve of the back.

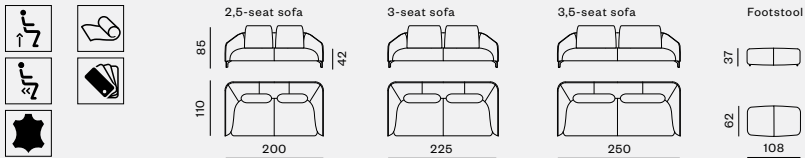

Flint

Inspiration – p. 58

Design: Beck Design, 2019

An extensive programme, with sofas, divans and modular elements to create large and small configurations. Such as a 90 degree corner or an exciting angled combination. The organic shapes of the seats and arms give Flint a friendly look, enhanced by its generous loose seating cushions. Flint is a bundle of energy, a strong design that demands its own place in your room.

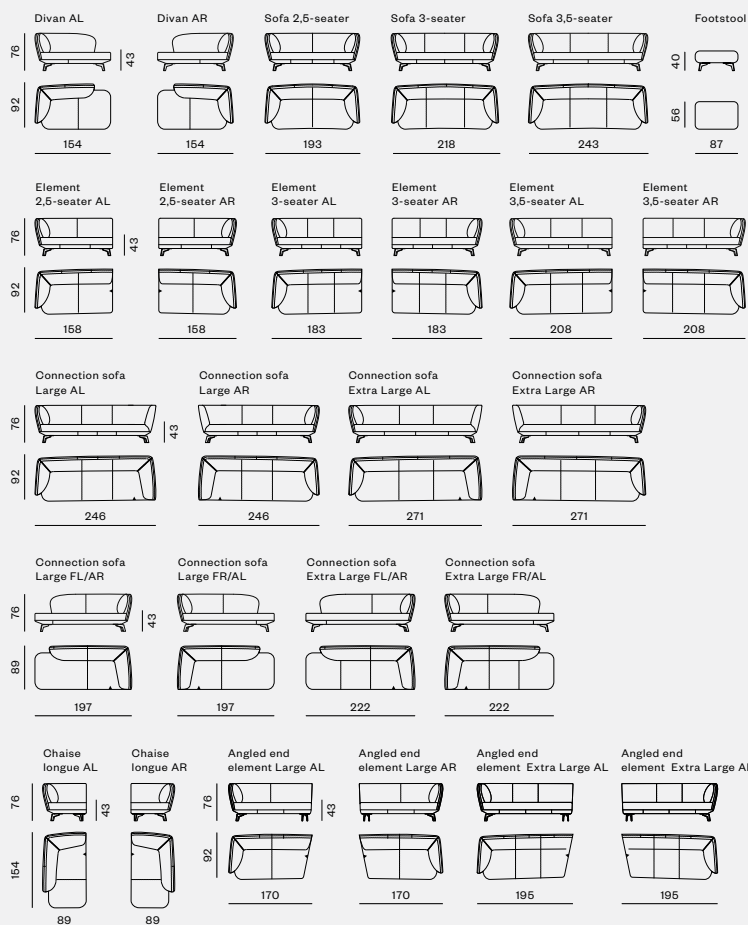

Examples

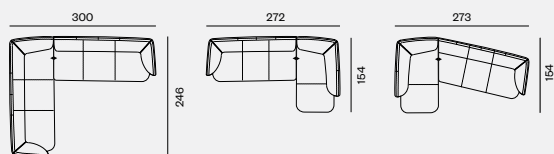

190

Guadalupe

Inspiration – p. 62

Design: Axel Enthoven, 1983

The Leolux Guadalupe elements enrich your interior like soft rounded, colourful islands. In a small setting as sofa or in a modular version that enables you to create every conceivable layout. The combination of eccentric basic shapes and colour combinations make this a unique product that can be personalised with the many Leolux fabric options.

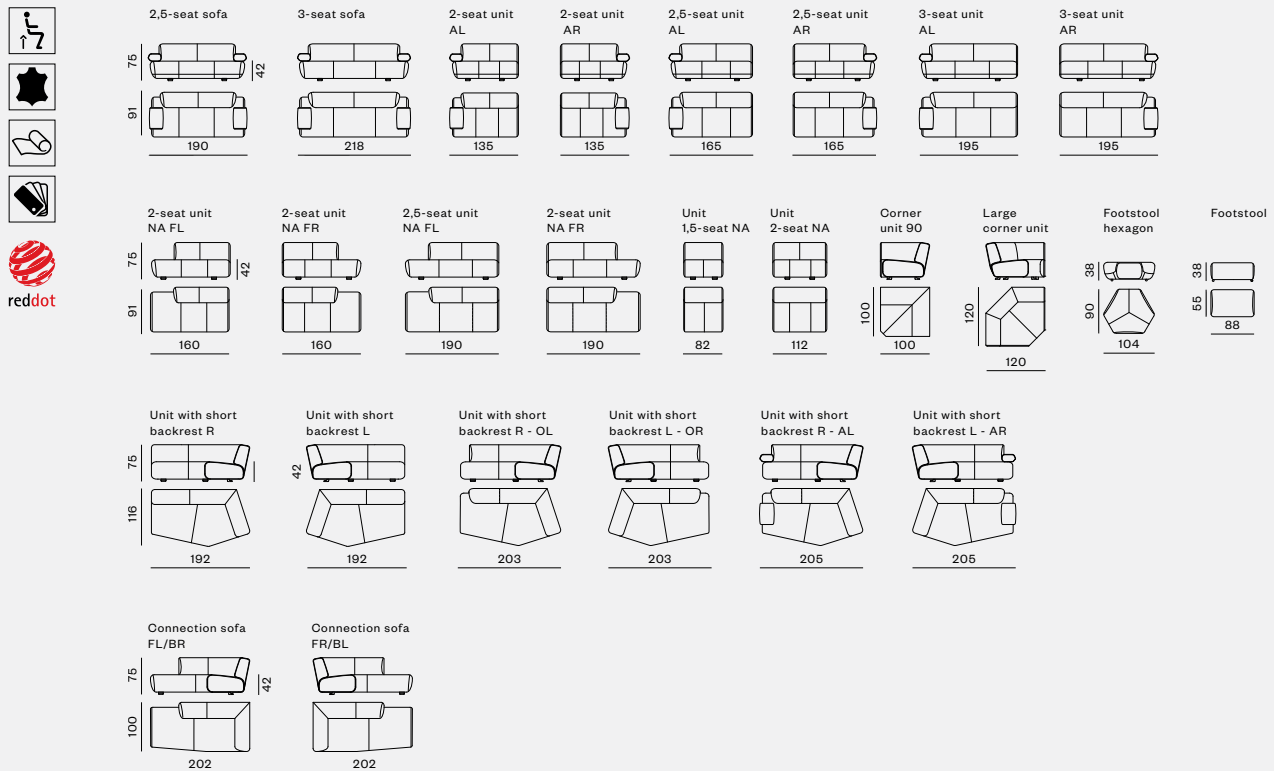

Example

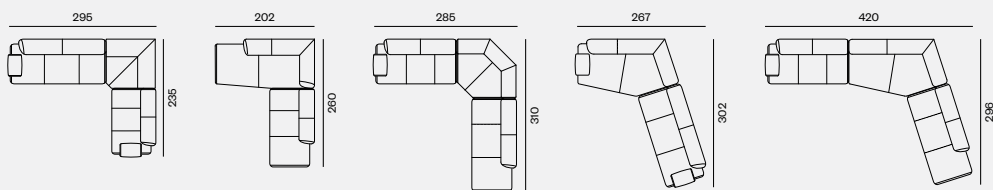

Gynko

Inspiration – p. 64

Design: Jörg Wulff & Thomas Müller, 2014

Friendly, inviting and functional. The round 'ears' of Gynko are fitted with an infinitely variable mechanism, enabling you to change the arms into a comfortable backrest for those moments of total relaxation. With different colours or fabrics for interior and exterior, Gynko offers you a truly personal look. Awarded the 2014 Interior Innovation Award and the 2014 Red Dot Design Award.



reddot

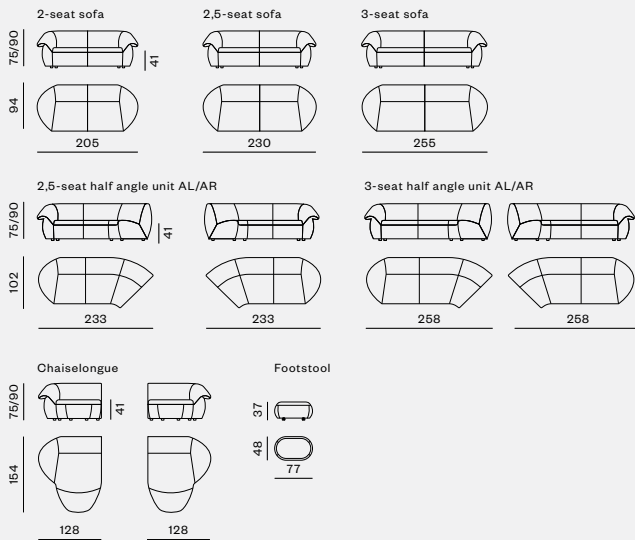

Example

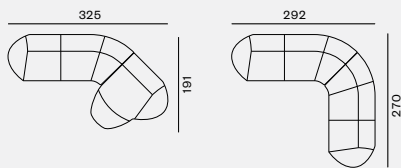

Ponton Next

Inspiration – p. 74

Design: Braun & Maniatis, 2008/2014

Revolving, sliding and matching; everything is possible with the Leolux Ponton. The cube elements invite you to enjoy endless experimentation. As the backs of the Ponton can be rotated in four positions, you can create comfortable nooks. Do you want to immerse yourself in a book while someone else watches a film? With Ponton everyone can create their ideal seating, all on the same item of furniture.

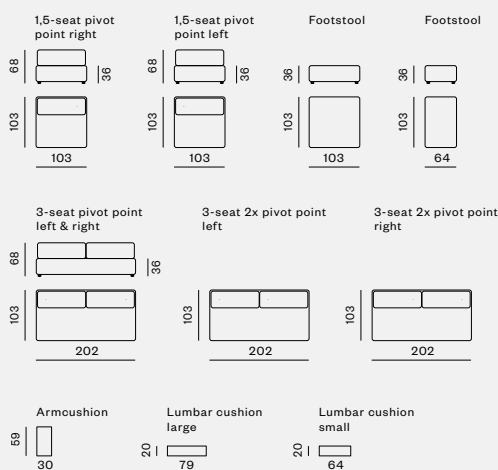

Example

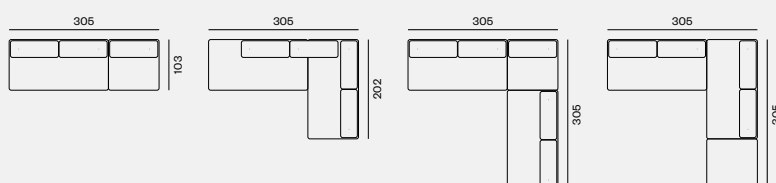

Rego

Inspiration – p. 76

Design: Gino Carollo, 2020

Rego is a design with pure Italian elegance. Original design enthusiasts will really love the curved elements. The curve is very slight, which provides an exciting visual effect, and they look absolutely stunning in combination with the round chaise longue.

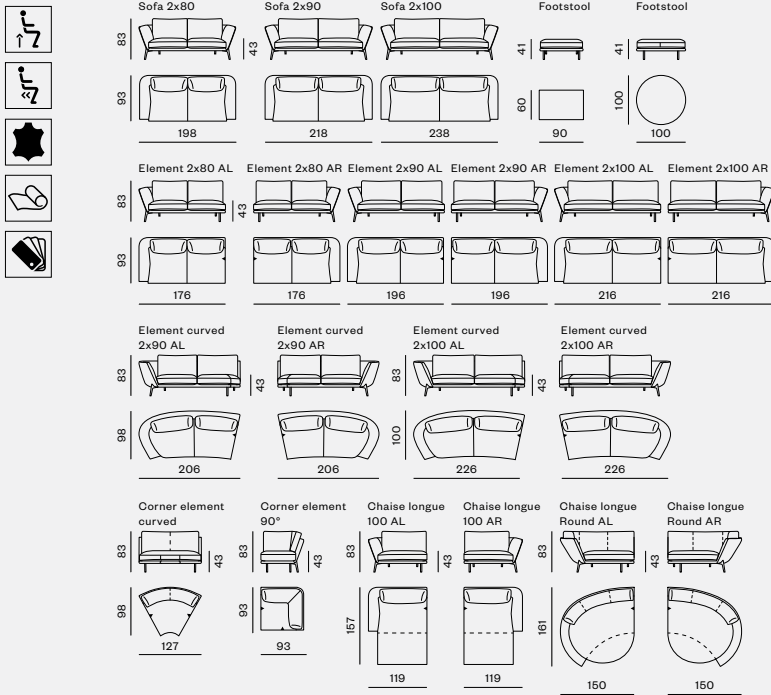

Example

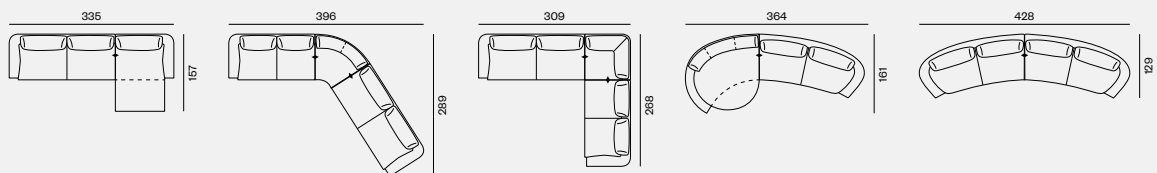

Tango

Inspiration – p. 82

Design: Jan Armgardt, 1984

A true 'classic' that has been a trendsetter for three decades. The Tango seat and back have adjustable left and right sections offering alternative application options in all positions.

A cosy 2-seater can be transformed into a wonderful reclining sofa with headrest and the generous 3-seater becomes even more spacious. Enjoy the beautiful features of this flexible character sofa.

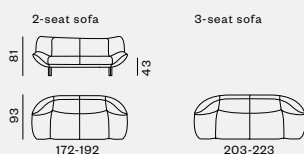

Vol de Rêve

Inspiration – p. 83

Design: Jane Worthington, 2006

A real masterpiece! The floating back, the organic lines and many treasured details make the Vol de Rêve a dream sofa that you can colour to your wishes. Select a 2.5 or 3.5-seat sofa or use the many options available within the modular sofa programme to compose your perfect layout. The large footstools complete the programme, bringing unparalleled luxurious combinations within reach.

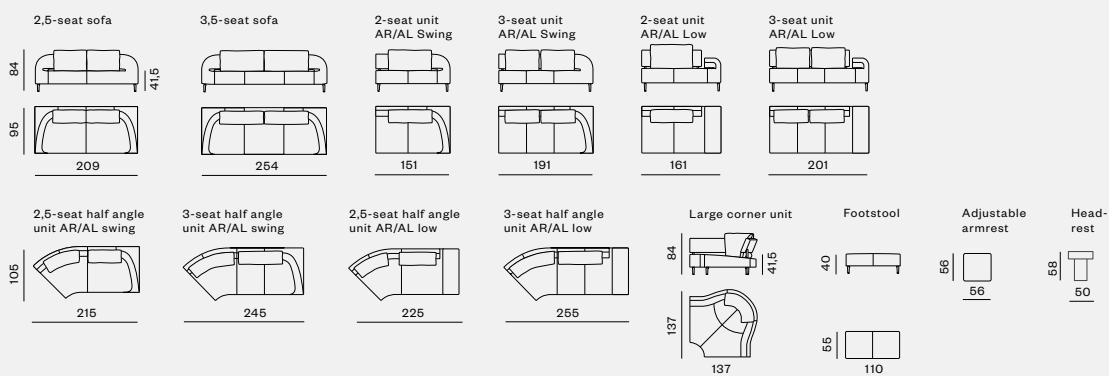

Example

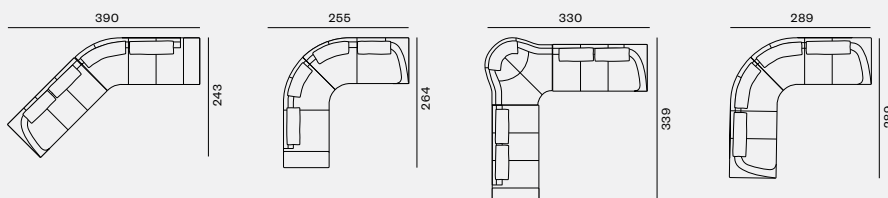

Cantate

Inspiration – p. 89

Design: Frans Schrofer, 2017

Cantate is a compact club chair that surrounds and supports your body. Beautifully finished at the back with the "Artisan" decorative stitch. The smart swivel base automatically returns to the start position when you leave the chair. And whatever you do, don't forget to experience the softness of the upholstery materials. Leather, fabric, or both, in a composition that you create yourself.

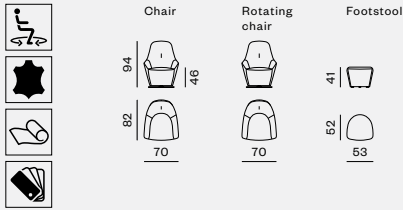

Caruzzo

Inspiration – p. 90

Design: Frans Schrofer, 2015

Caruzzo is unparalleled in many respects. The curved lines of this swivel chair create movement in this timeless design and give it momentum. With the hand-sewn 'Artisan' stitch, Leolux is presenting a powerful example of hand-crafted art, while modern technology provides the perfect seating position for every moment of the day. It's not without reason that Caruzzo was awarded the 2015 Red Dot Design Award and the 2015 Good Industrial Design award. Available with two types of bases 'Original' or 'Pure'.

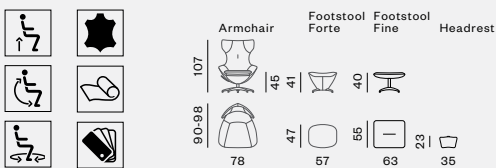

Darius

Inspiration – p. 94

Design: Jan Armgardt, 2013

This is the king of armchairs. Darius's high protective back and soft spring frame ensures total relaxation. The line of the armrests flows naturally into the seat and back, complementing the perfect organic design. For the right look, select upholstery for the inside and the outside and any lacquer or epoxy for the frame.

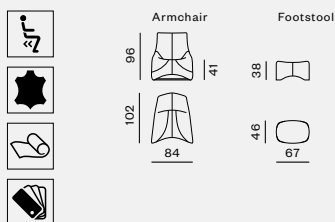

Dolcinea

Inspiration – p. 95

Design: Jan Armgardt, 1992

Active, compact and comfortable, with a back that shapes to your body. The curved base of the Dolcinea makes standing up easy and prevents damage; smart features that give this distinctive classic that decisive advantage. You can choose the upholstery, the leg finish and the seating height so that Dolcinea is personalised entirely to your requirements.



Hilco

Inspiration – p. 96

Design: Patrick Belli, 2019

Logic and simplicity are the starting points of the Hilco lounge armchair. The design, in which the shells of the seat and back slide to fit together, clearly shows how the armchair's comfort is created. The curvature in the back gives just the right amount of support, making Hilco an excellent choice.

A unique story

The story behind Hilco is unique. To reduce the CO2 footprint as much as possible, the armchair is actually constructed entirely from materials from the local region. This particularly applies to the 'Prime' version in beautiful Corus leather. This biodegradable, chrome-free and entirely traceable full grain leather originates from Limburg Limousin cattle.

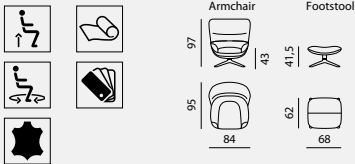

Indra

Inspiration – p. 97

Design: Cuno Frommherz, 2015

Your own universe for dreams and ideas. The armchair that perfectly fulfils this function is of true value for its user. Cuno Frommherz embodied this vision in the Indra armchair, with the softness and elegance that fulfil these wishes. The seat of this armchair appears to float in a trapezoid frame. The seating cushion that rests on it is divided into softly filled segments that embrace you.

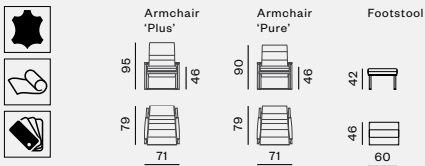

Jill

Inspiration – p. 98

Design: Edward van Vliet, 2018

The design references a bygone era, inspired by 19th-century luxury interiors. The Edward van Vliet style is distinctly evident in the armchair and chaise longue. He combines a touch of nostalgia with contemporary comfort, charming curves and elegant details, such as the legs, the decorative stitching and the button accent in the centre of the lower back cushion.

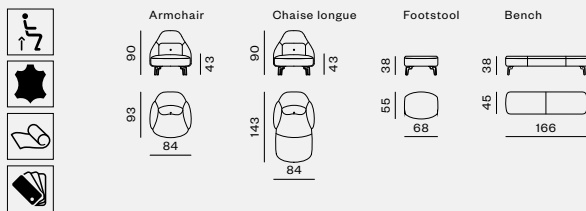

Kikko

Inspiration – p. 99

Design: Hugo de Ruiter, 2000

Is it a chaise longue? Yes, but Kikko offers many more possibilities. If you lift the back lightly, you can rotate it 90 degrees left or right, transforming your chaise longue into a truly comfortable seat. You can choose from two colours for the seat and back, offering you a canvas for tasteful combinations that are just as versatile as the comfort of this unique Hugo de Ruiter design.

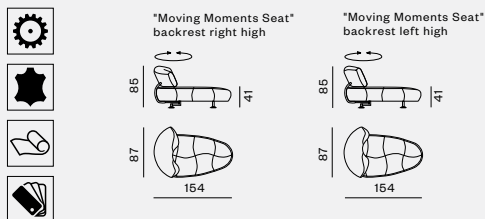

200

Lloyd

Inspiration – p. 100

Design: Gino Carollo, 2018

Lloyd is a design beacon in your living room. Cool, yet so inviting. With supple, almost nonchalant upholstery and crafted details, such as decorative piping to emphasise the strong shape. The inside and the outside can be chosen separately, as can the colour of the legs and the decorative stitching. The recliner lever is upholstered in leather.

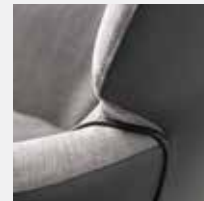
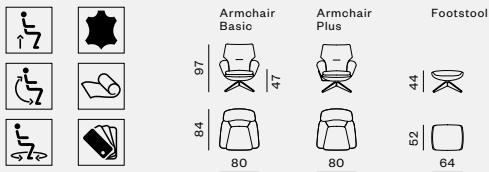

Mayuro

Inspiration – p. 101

Design: Christian Werner, 2013

Building on the successful Mayon series, Leolux has created the Mayuro armchair, with more compact dimensions and active comfort. The beautiful upholstery accents, including attractive dimples in the sides and loose upholstery are what make Mayuro truly elegant, just like the specially designed legs. All these elements create stunning enrichment for contemporary interiors.

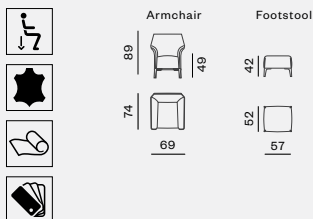

Pallone

Inspiration – p. 102

Design: Boonzaaijer / Mazairac / de Scheemaker, 1989

This was originally designed for the House of the Future. Pallone is perhaps the best-known Leolux armchair. This is undoubtedly due to its futuristic design, but without the legendary Leolux comfort the relevance would certainly have been lost. Available in multiple sizes and in numerous colour and upholstery fabric options. Pallone has personality, and is the perfect eye-catcher for distinctive interiors.

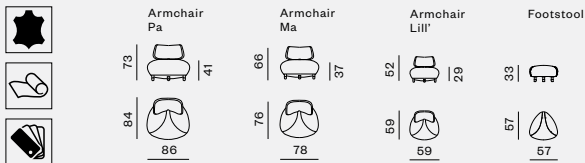

Papageno

Inspiration – p. 104

Design: Jan Armgardt, 1993

Papageno is the Leolux symbol for playfulness, amusement and humour. The striking aluminium legs, the lightly sprung back and beautiful organic form make Papageno an eye-catcher that's difficult to date. And yet this Leolux classic has been around for over twenty years. Arty and playful, design with stunning organic forms.

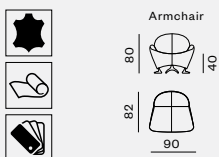

202

Parabolica

Inspiration – p. 106

Design: Stefan Heiliger, 2009

With its powerful design, the Parabolica swivel chair is a fantastic object in your living room. The asymmetrical form enables at least three different types of use: 'normal' sitting, relaxed reclining or active sitting with the armrest as a small workstation. A true eye-catcher, with tremendous versatility. You can select different upholstery for the inside and the outside and the band between the two.

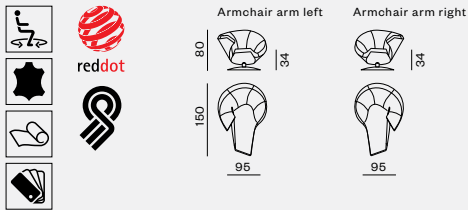

Scylla

Inspiration – p. 108

Design: Gerard Vollenbrock, 1996

Gerard Vollenbrock designed this traditional Dutch Scylla with references to 'De Stijl'. He gave the sober design a stunning tube frame that runs entirely along the back and sturdy upholstered armrests. It is the small details and perfectionist finish that ensure that this design easily passes every test, even after many years. Because it's only under these conditions that true timeless design is created.

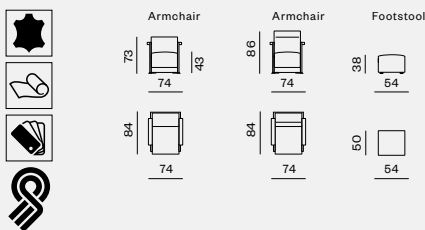

Volare

Inspiration – p. 110

Design: Jan Armgardt, 1998

Volare is a generous armchair with the minimalist industrial design that is so distinctive of wire furniture. However, the comfort is anything but minimalistic. The thick cushions pamper you with wonderful springy comfort. Quilted for a luxurious look. Sitting almost feels like floating. Of course, you have complete control of the styling, both in terms of frame colour and the upholstery.

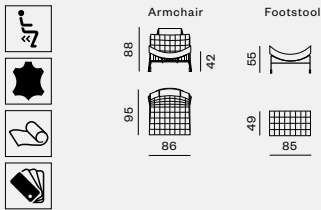

Callas

Inspiration – p. 116

Design: Frans Schrofer, 2015

Callas is an expressive eye-catcher at the table. You can select the front, back and legs for each Callas chair to create a mix that is a perfect match for your taste. As standard, Callas has a sturdy zip at the back, but for that extra grand finish, Callas offers Artisan: a skilfully sewn decorative stitch that replaces the zip at the back.



Caron

Inspiration – p. 118

Design: Frans Schrofer, 2018

The comfortable Caron bar stool is a Frans Schrofer design and is a clear continuation of the stylish elements of the Caruzzo, Cantate and Callas models. The Caron finish is also entirely in line: as alternative to the sturdy zip on the back, you could decide to go for the handcrafted 'Artisan' decorative seam. It can be used as bar stool or counter height stool and you can choose from every fabric and leather from the collection for the inside and outside upholstery.

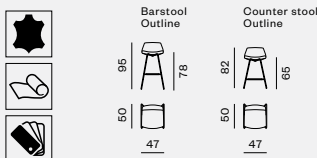

Ditte / Didore

Inspiration – p. 118

Design: Cuno Frommherz, 2017

For Leolux, designer Cuno Frommherz created a contemporary version of the traditional dining room bench: light and transparent, with comfortable and active seating. You can style Didore exactly the way you want it. And the same applies to the Ditte chair, with which you can create your own combination of colours and materials. This freedom makes Ditte and Didore excellent choices for almost every contemporary interior.



Ditte



Didore

Freyr

Inspiration – p. 120
 Design: Erik Munnikhof, 2003

In Freyr, Leolux combines the classic curved tubular frame with contemporary comfort. The springy seat is so characteristic of the cantilever and the options you expect from Leolux. Select your own version; with or without armrests (oak, walnut or leather) and a frame in chrome, lacquer or epoxy. This makes Freyr the perfect symbiosis between then and now.

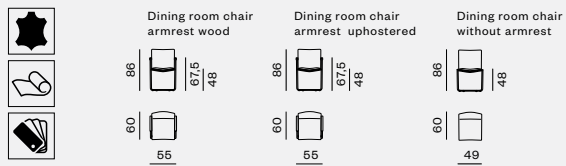
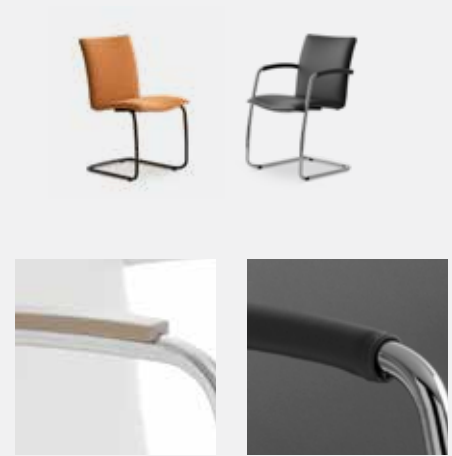

Mara

Inspiration – p. 121
 Design: Christian Werner, 2016

Unmistakably a Christian Werner design: the curves of the shell seat, the light nonchalance of the upholstery, the refined finish. Mara is a fitting choice in many contemporary interiors due to the different frames: solid oak legs (Palo) are a great match for the oak tables in the Leolux collection; sleek-looking sledge frame (Outline), a pivot base (Cruz) or a frame on castors (Twist).

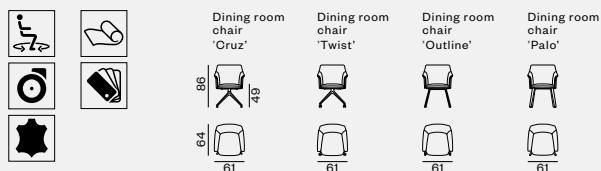

Mime

Inspiration – p. 122
 Design: Gino Carollo, 2019

Designer Gino Carollo provided the Mime dining-room chair with stunning details, such as soft pleats, the accent on the front face of the back and beautiful decorative stitching. Mime is available with and without armrests. Further variation is possible by using different materials for the inside and outside and by combining different bases.

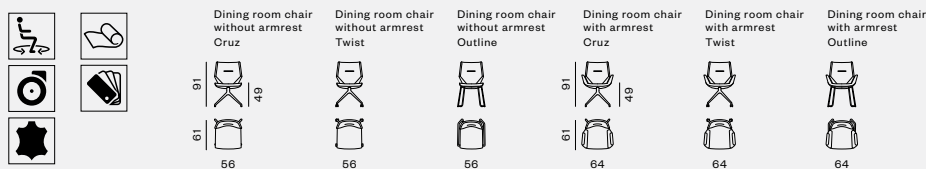

206

Talos

Inspiration – p. 124

Design: Scooter & Partners, 2006

Enjoyable dining places strict requirements on a dining-room chair. Talos is a strong candidate, with a stylish design, high level of comfort and a contemporary frame in chrome, lacquer or epoxy. Arm rests are finished in leather, lacquer, oak or walnut. The frame is available in chrome, lacquer or epoxy. The modest dimensions mean that Talos can even be used with smaller dining-room tables.

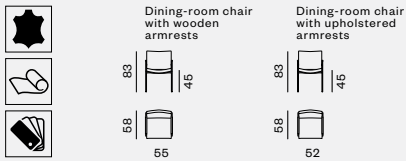

Tamarinde

Inspiration – p. 126

Design: Frans Schrofer, 2013

A slim design with inviting projecting arms and an infinitely variable back that you can adjust to the ideal position after dessert. Depending on the function that you have in mind for Tamarinde, you could go for swivel castors or legs in aluminium, lacquer or epoxy. Whatever you choose, you'll enjoy endless comfort, ensuring that good after-dinner conversations simply go on for hours.



Aditi

Inspiration – p. 132
 Design: Minimal Design, 2002

Simple is all you need sometimes. The refined finish of Aditi offers you the choice of a rectangular or square model. Both versions have a practical glass lower table top for storing small items. The solid wood upper table top has a truly natural look. And if you're a devotee of a colourful interior, you can select a lacquered upper table top.

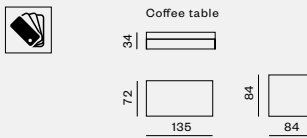

Cimber

Inspiration – p. 133
 Design: Frans Schrofer, 2012

A playful table with legs like open hairpins. The leaves are available in lacquer, oak or walnut and in three sizes and three heights. You can combine the two largest by pushing them together or you can partly slide them over each other. The smallest Cimber is the perfect occasional table. The characteristic base of these tables is chrome, but you could also go for lacquer or a beautiful epoxy colour.

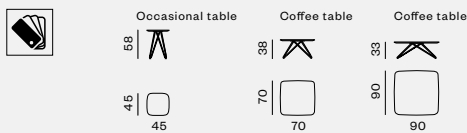

Coda

Inspiration – p. 134
 Design: Pascal Bosetti, 2018

The stylish wire frame imparts a transparency to these occasional tables and coffee tables. Making combinations with Coda is an adventure in itself, because you have the choice of a wide range of lacquer and epoxy colours. If you look closely, you can see subtle differences: the large coffee table has a pentagonal base and a raised edge all around, while the smaller occasional table has a triangular wire frame with a table top that is curved on just one side.



Griffo

Inspiration – p. 136

Design: Scooter & Partners, 2015

A portable, practical table that you can move easily to wherever you need it. With a handy handle underneath the table top. This table top, which you can easily move across the seat or a low arm of your sofa, is available in oak or lacquer, with the frame in aluminium, lacquer or epoxy. This makes Griffo a fantastic and practical addition to your living comfort and it takes up hardly any space.

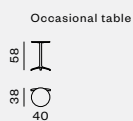

Iduna

Inspiration – p. 137

Design: Beck Design, 2017

Natural shapes and materials bring calm to your living room because they exude softness and quality. That is the first thing that strikes you when you see the Iduna coffee tables. The tapering wooden legs support the marble or solid oak table top. Large or small, in a high or a low version, for the most beautiful combinations.

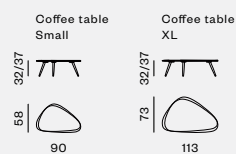

Liliom

Inspiration – p. 138
 Design: Norbert Beck, 2010

Organically designed tables in various shapes and heights. Stack them over each other for a neat look. For a natural accent, select a solid walnut or oak table top. A lacquer finish gives you the option of colour. But Liliom goes even further, because you could also have a practical and truly stylish ceramic table top. A beautiful frame in chrome, epoxy or lacquer enables you to create timeless combinations.

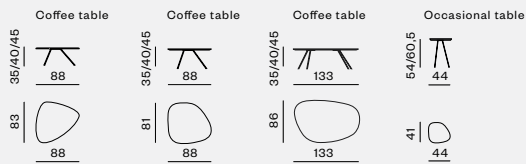

Lys

Inspiration – p. 140
 Design: Beck Design, 2018

Lys is an inviting high table, which forms a perfect combination with the Caron bar stools. The organic shape of the larger table top, available in solid oak or walnut, offers a comfortable place for a get-together over a tea or coffee. At the same time, the lower leaf offers fantastic extra storage space.



210

Ninfea

Inspiration – p. 141, 142

Design: Stephan Veit, 2015

Ninfea offers many colourful choices and is very flexible. The table tops revolve around a point that the designer has placed just off-centre. You rotate each table top for as long as it takes to find the configuration you need. The leaves of 'Rondo' are rounded and the 'Clover' are table top-shaped. Both versions are available in various finishes: lacquer, wood or ceramic.

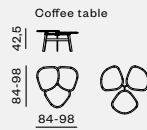
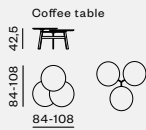

Portello

Inspiration – p. 143

Design: Patrick Belli, 2013

Portello is light, refined and incredibly practical. The table is completely in balance if you lift it using the grip that is hidden on the bottom of the table top. That table top also fits perfectly above the seat of your Leolux sofa, so you have everything within easy reach, from remote control to cup of tea. The leaves are finished in lacquer or in solid oak and the frame in aluminium, lacquer or epoxy.



Prismo

Inspiration – p. 144

Design: Edward van Vliet, 2017

The extensive Prismo table series was designed by Edward van Vliet and is all about the interplay between square and circle-shaped leaves and bases. If the table top is square, the frame is circular and vice versa. You can experience this effect to the full in the glass leaves, but this is also a stylish feature in the Prismo ceramic table top. Timeless design for interiors created with love and the utmost care.

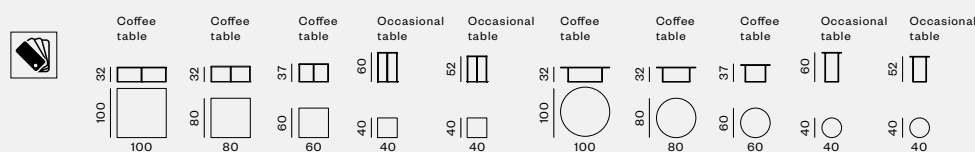

Rolan

Inspiration – p. 146

Design: Gino Carollo, 2020

The Rolan table series is characterised by the streamlined form that you would expect from Italian designs. There are five different versions: three round tables, one oval one and one rectangular one. Each size is available in two different heights: 31 and 37 centimetres. The table top is available in solid oak or walnut, but there is also a ceramic table top.

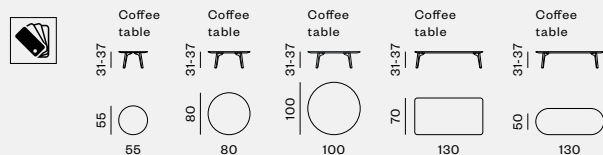

Tampa / Troy

Inspiration – p. 148

Design: Beck Design, 2019

The Tampa tables combine their useful function and colourful look with a playful shape. Stunning compositions can be created by combining various leaf shapes. Tampa is available in a beautiful fixed version with a round, bean-shaped or oval table top. The materials also differ per version, from oak or walnut to marble, glass or lacquer. The combination with "Troy" is decorative and functional; this tray looks fantastic on the coffee table frames.

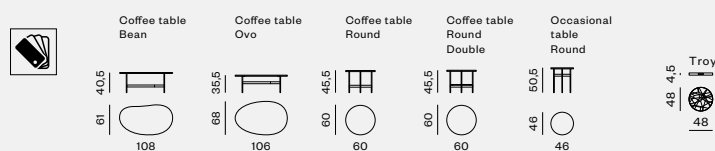

Bondi

Inspiration – p. 150

Design: A Design Studio, 2019

This table adds a wealth of colour to every interior. Bondi's unusual organic wing shape is the first thing you notice. This creates space for at least five users. The three-leg steel frame offers stability and the table top gives Bondi character in oak, walnut or user-friendly Fenix. (Not available in the USA)

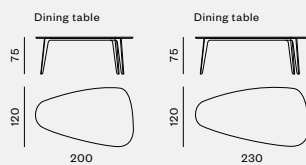

Columna

Inspiration – p. 152

Design: Hugo de Ruiter, 2016

Columna by Leolux is a very practical table. Round or oval, to ensure that it offers space for the maximum number of guests, without awkward table legs. The table top is available in solid walnut or oak, ceramic or lacquer. A beautiful detail of this subtle table is the way in which the column connects to the leg: like an ancient marble column, smooth or fluted. Columna is also available in XL-versions that have two columns.

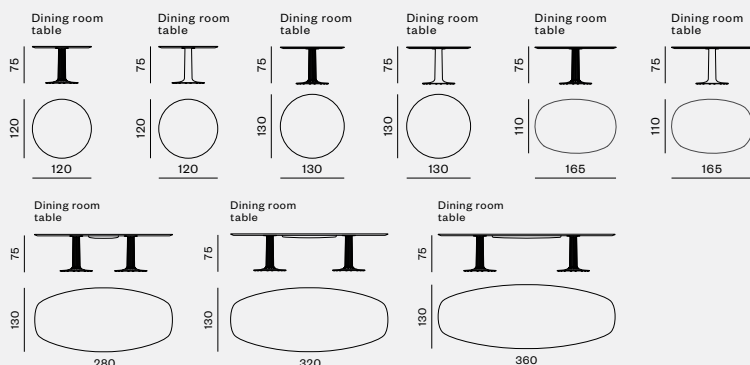

Kalia

Inspiration – p. 154

Design: A Design Studio, 2012

A modern and sleek personality with an extremely luxurious look: that is Kalia by Leolux. The table offers you all the space you need for extensive dining with friends or family, as the biggest Kalia version is some 280 centimetres! The frame is available in epoxy and lacquered colours to give your table the perfect finishing touch. And for the table top you can choose from various wood options and the particularly practical Fenix. (Not available in the USA)

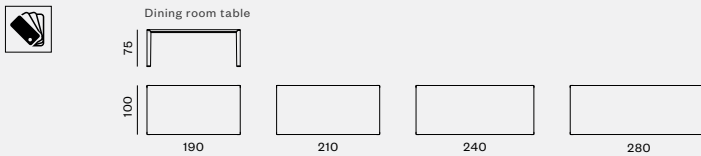

Yama

Inspiration – p. 156

Design: A design studio, 2017

Yama is a real eye-catcher and is available in different lengths. With straight lines and subtle profiles in black aluminium, giving the sides a streamlined look. The different parts of the table top, in solid walnut or oak, have been chosen with great care so that they create the most natural look for your Yama table. The extendible tables are fitted with a grip under the table top and invisible wheels.

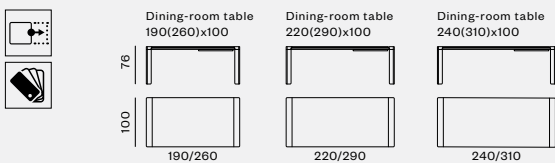

Cosy Cushions

Inspiration – p. 162
 Design: Leolux, 2013

Leolux developed an extremely complete cushion collection for that perfect look. Customised, available in five dimensions, in any type of Leolux upholstery fabric and with a choice of no fewer than five finishes. So why would you select cushions off the shelf? The 'Pure' padding contains a combination of foam and small feathers. The 'Royal' padding is foam and is also suitable for people with an allergy to down.

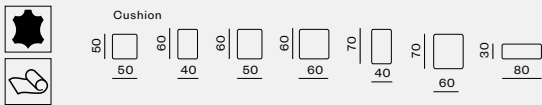

Cushion Lusso

Inspiration – p. 163
 Design: Scooter & Partners, 2018

Lusso is unique in its decorative value, with the embroidered motif on the front giving the cushion a fun, modern element. You can totally personalise Lusso when you choose the materials and the colours from the Leolux collection: fabric or leather on the front, fabric on the back. For wonderfully soft comfort, we fill your cushion with duck feathers, which we combine with high-quality foam.

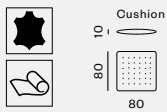

216

Topsy Turvy

Inspiration – p. 166

Design: Edward van Vliet, 2017

Upside down, back-to-front and inside out; that's what "Topsy Turvy" means in English. It perfectly expresses what Edward van Vliet intended when he developed this unusual accessory. A cushion that literally has two faces: a fabric side and a leather side. When folded open, Topsy Turvy has a decorative function when you nonchalantly lay it over the armrest like a plaid blanket. That way, it can also be used as back support for smaller users of your sofa. Then when you close Topsy Turvy with the retro wooden buttons, you suddenly have a lovely soft cushion.

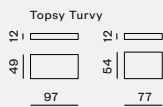

Amund

Inspiration – p. 167

Design: Maghalie Doods, 2020

The Amund rug is a very soft rug that feels comfortable to the feet. It is available in three sizes: two rectangular ones (200 x 300 cm and 240 x 340 cm) and a round version with a diameter of 280 cm. All three sizes of this rug are available in five different natural colours.

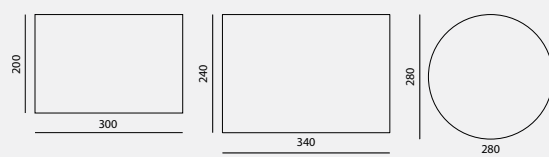

Polar Fox



Reindeer



Bear

Girisha

Inspiration – p. 168

Design: Edward van Vliet, 2017

Using costly high-quality wool, specialists in India manufacture the Girisha rugs for Edward van Vliet's Leolux collection. In different sizes and colour themes, hand-tufted and manufactured with high-quality threads. The graphical motif of timeless triangles is applied on a lower level so that these rugs are given extra depth.

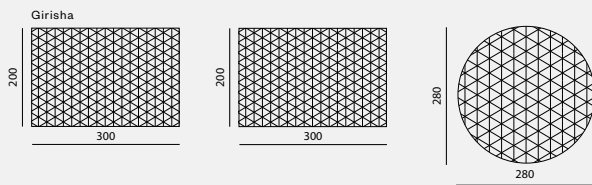

Red

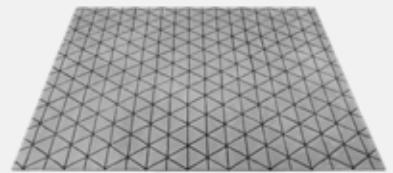

Blue



Yellow

Izem

Inspiration – p. 168

Design: Edward van Vliet, 2017

Edward van Vliet is always looking for equilibrium. Colours, patterns and use of materials must be in balance and form a whole. By opting for timeless motifs, Van Vliet always succeeds in creating new combinations that nevertheless seem familiar. With the Izem rugs, he put this working method into practice by combining a cube pattern with almost classical colour combinations and a vintage look. Izem is a beautiful machine-woven rug in the soft pastel tint of "Cream" with olive-green cubes, or deep warm blue-grey with dark red.

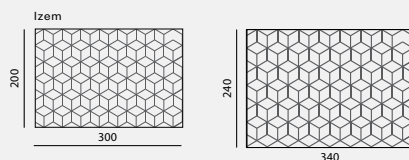

Blue



Cream

Mizu

Inspiration – p. 169

Design: Edward van Vliet, 2018

Edward van Vliet has a unique talent for creating balance between colour, patterns and use of materials. He chooses timeless patterns, then makes new combinations with them that somehow seem to belong. Van Vliet's hand is immediately evident in the rug Mizu. The geometrical pattern on the foreground is characteristic of his work and in the background we see the flowing water that the name "Mizu" refers to. The combination of the softness in the background and the hard, graphic lines in the foreground creates tension and contrast.

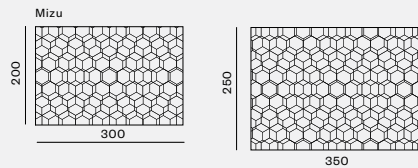

Buru



Chairo



Beju

Patna

Inspiration – p. 170

Design: Leolux, 2018.

The Leolux rug collection offers various size, colour and pattern options. A really beautiful choice is the Patna rug. A beautiful hand-made rug, in six warm colours, with an accent colour that is incorporated in little loops throughout the rug. Patna is manufactured entirely from viscose, which provides a stunning sheen.

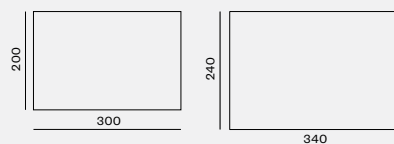

12 Chalk



13 Beige



22 Light Grey



23 Grey

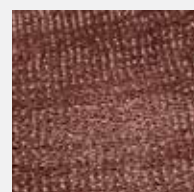

44 Burgundy

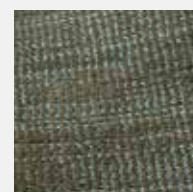

53 Taupe

Sperto

Inspiration – p. 170

Design: Maghalie Dooms, 2020

The Sperto drawing stimulates your fantasy. You can see anything you like in it, from a cloudy sky to a road map. Sperto is a rug with blended shades that always form the perfect foundation for your interior. All four colours are available in two rectangular versions (200 x 300 cm and 240 x 340 cm) and a round version, which is 280 cm in diameter.

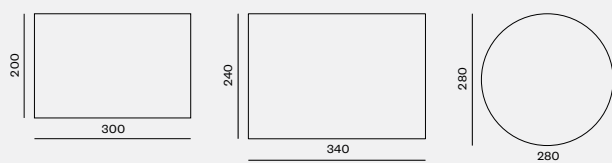

Brick



Bronze



Concrete



Sky

Amulet

Inspiration – p. 171

Design: Edward van Vliet, 2017

Edward van Vliet's Amulet series: eye-catching because of its shape and proportions, and practical in daily use. There are two types (I and II). Both have a sloping base, but one of the two also sees these facets carried through to the top. The octagonal footstool offers an extra place to sit, but is also very handy as a side table due to its sturdy, flat seat.

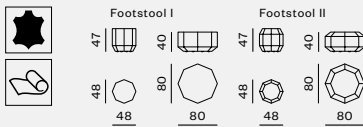

Capri

Inspiration – p. 171

Design: Edward van Vliet, 2018

Capri blends into the most elegant interiors. Besides the basic footstool features, which are comfort and flexibility, the Capri's refined details make it so much more. The footstool seems to float on hidden wheels and the vertical pleats feature artisan stitching. These characteristics transform Capri into a showpiece and standalone feature of your interior.

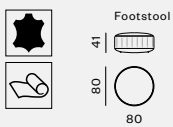

Funo

Inspiration – p. 172

Design: Michael Raasch, 2020

Funo provides both atmospheric as well as functional lighting. The atmospheric lighting is located right at the top of the shade. This contains a round bulb that you can operate using the dimmer in the foot switch. It generates warm light, and this in turn creates a cosy atmosphere. The second light source, a small reading light, is at the bottom, under the edge of the shade. (2700 Kelvin, lightning only available with euro and UK plug)



Qone

Inspiration – p. 172

Design: Michael Raasch, 2020

The Qone reading light was designed by Michael Raasch. The streamlined geometric shapes in the design show overtones of the Bauhaus style, and the spotlight shade is golden in colour, which makes it stand out against the black frame. (2700 Kelvin, lightning only available with euro and UK plug)

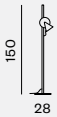

The most stunning materials

Every Leolux product is manufactured entirely from high-quality materials. Each contributes to the quality, feel and look of your new Leolux. Of course, the upholstery plays an important role in upholstered furniture, but that's not the only important feature. You also have a huge choice of wood, lacquer, marble and much more. That's why we're itemising the many beautiful materials from our collection in these pages.

At Leolux, we are fervent admirers of leather as an upholstery material. Because whoever chooses leather chooses character. Leather is a natural product, and it exudes the quality that we feel so strongly about. Each type of leather has its own specific features and properties, such as the type of finish, feel and type of use. That is why we would like to explain about the various leather types.

Wapiti

With Wapiti leather, you get dependability with everyday use. Its appearance is defined by a specific tanning method and the characteristic Wapiti grain that is applied during the finishing process.

Finish: pigmented
Emotion: reliable and soft leather for rigorous use
Type of use: intensive
Thickness: 1.1 – 1.3 mm

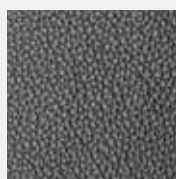

1 Black



120 Alba



129 Triel



200 Kepanki



330 Goura



400 Toerako

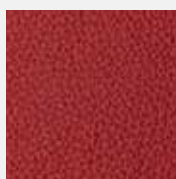

607 Kardinaal

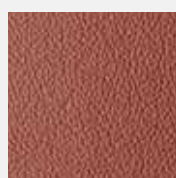

610 Carmina

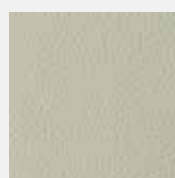

900 Sabaku



910 Chuchubi

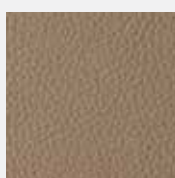

1107 Nomade



1386 Hazy

Senso

The high-quality finish provides extra protection against external influences such as light, dirt and dust. The hide thickness and the robust structure of Senso give furniture a special cachet that is admired by all lovers of strong leather qualities.

Finish: pigmented
Emotion: leather with body that is extremely durable
Type of use: intensive
Thickness: 1.4 – 1.7 mm

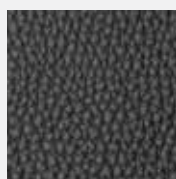

1000 Black



1077 Ferrari



1110 Rose

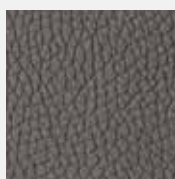

1120 Castor



1290 Mist



2000 Cobalt

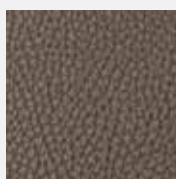

2100 Walnut

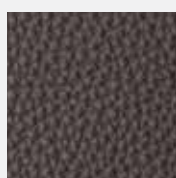

2210 Chocolate

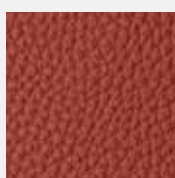

2260 Terracotta



2500 Chicco

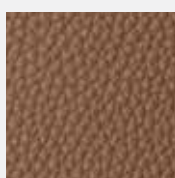

2960 Camel

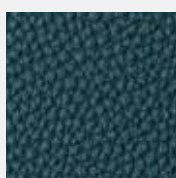

3040 Teal

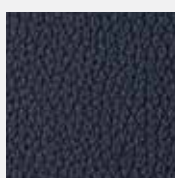

3100 Eclipse



3110 Agate



3210 Tempest

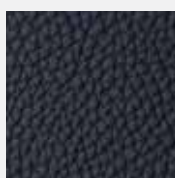

3610 Indigo



3890 Heaven

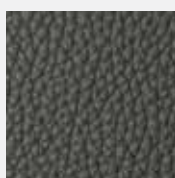

3906 Ombra

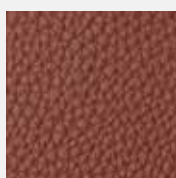

4100 Rust

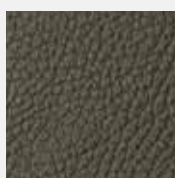

4210 Avocado

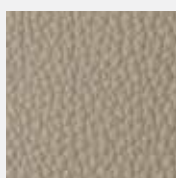

4400 Off-White



5000 Berry



5100 Iris

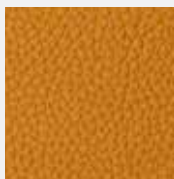

6000 Gold



6100 Petal



6110 Olivine

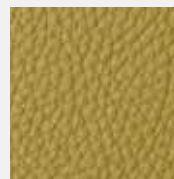

6200 Sprig

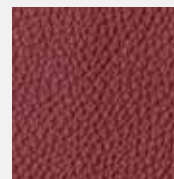

6620 Brick



6700 Cinnabar

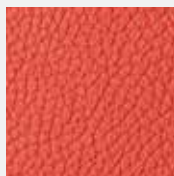

6870 Grenadine

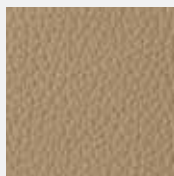

7200 Sahel

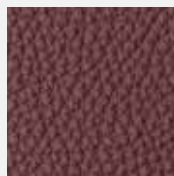

7300 Granata



7600 Apricot

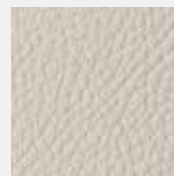

8000 Polar

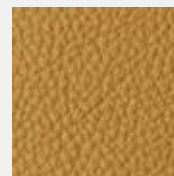

8100 Amber



8700 Mimosa

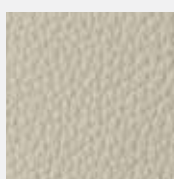

9080 Egret



9100 Dawn

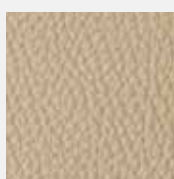

9780 Ginger

Ceras

Ceras is a soft grain leather with brilliant colours that is nevertheless very suitable for daily use. The surface area is lightly polished, so the original structure of the hide is preserved. A perfect choice for lovers of leather with a luxurious touch.

Finish: semi-aniline
Emotion: pure nature, rich and luxurious
Type of use: normal
Thickness: 1.2 - 1.4 mm



1090 Flint

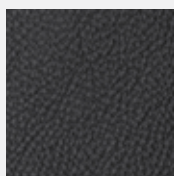

1100 Peat



1130 Rock



2110 Brindle



2210 Earth



2510 Brandy

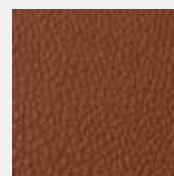

2620 Auburn

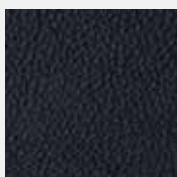

3100 Mazarine

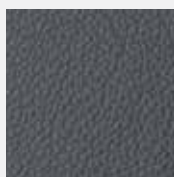

3190 Dew



3900 Tourmaline

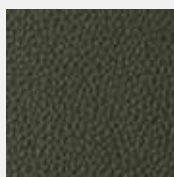

4210 Leaf

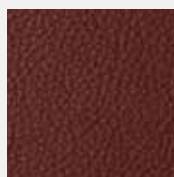

6200 Maroon

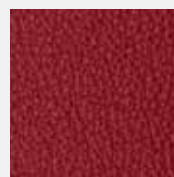

6600 Siam

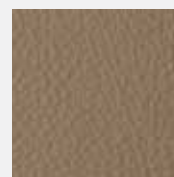

9220 Shell



9910 Pristine

Raffino

Raffino has the soft grip that is so characteristic of authentic natural leather. It has the hallmarks of real leather that the thin protective layer cannot hide. This layer ensures that Raffino is more resistant to dirt, but it still needs to be treated with care during everyday use.

Finish: smoothed aniline
Emotion: pure and luxurious natural leather
Type of use: elegant
Thickness: 1.4 - 1.6 mm



100 Panther



130 Dragonfly



200 Mink



266 Kodiak



290 Koala

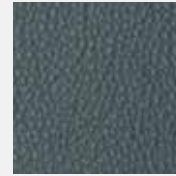

340 Whale

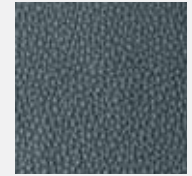

400 Turtle



550 Dove

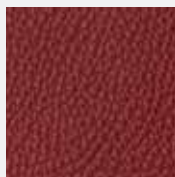

600 Puma



720 Fox

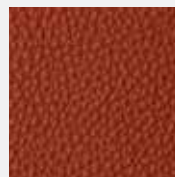

760 Lion

Danza

Leolux Danza is pure aniline leather that proudly displays the marks of authenticity and nature's colour variations. The lightly roughened surface and the oiled finish make this leather supremely supple and soft. Danza develops a beautiful patina in the course of time.

Finish: aniline
Emotion: natural, soft and vintage
Type of use: elegant
Thickness: 1.1 - 1.3 mm

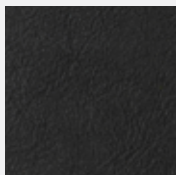

100 Phantom

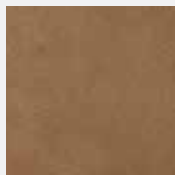

209 Moreno

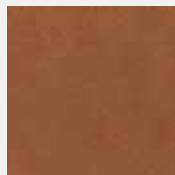

268 Mocha

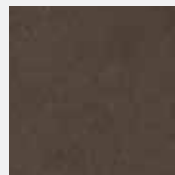

270 Bombay

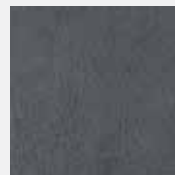

315 Mirage

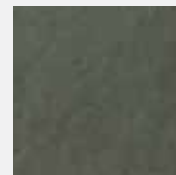

410 Olive

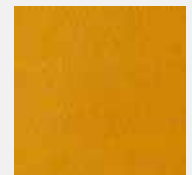

820 Ochre

226

Noli

Noli is a naturally pure leather with an exclusive full-grain quality and a buffed aniline finish. It is finished with a custom-designed Leolux finish. This enables Noli leather to retain its silky grain feeling and a transparent depth.

Finish: smoothed aniline
Emotion: a natural, silky feeling
Type of use: elegant
Thickness: 1.4 – 1.6 mm



100 Carbone



190 Argento



210 Ramo

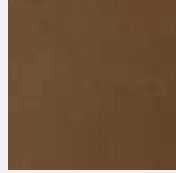

272 Oliva



620 Moka

Negev

This aniline leather proudly displays its origin and radiates strength and authenticity. Visual deviations in the hide, such as structural differences and skin folds, are deliberately integrated into the leather rather than removed by Leolux's leather specialists.

Finish: smoothed aniline
Emotion: rugged and generous,
with a luxurious feel
Type of use: elegant
Thickness: 2.1 – 2.4 mm



100 Noche

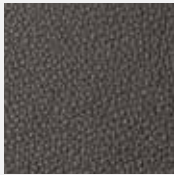

210 Nervio



226 Duna



269 Arena

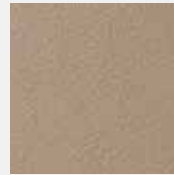

920 Seco

If you prefer fabric upholstery, Leolux also has a wide range of options. Beautiful woven materials, produced by trusted suppliers such as Kvadrat and De Ploeg. Whatever the feel, colour and type of use, there is a fabric that offers the perfect answer to your requirements and the style you had in mind for your new furniture.

Loft

Not available in all UK



Fay

Not available in all UK

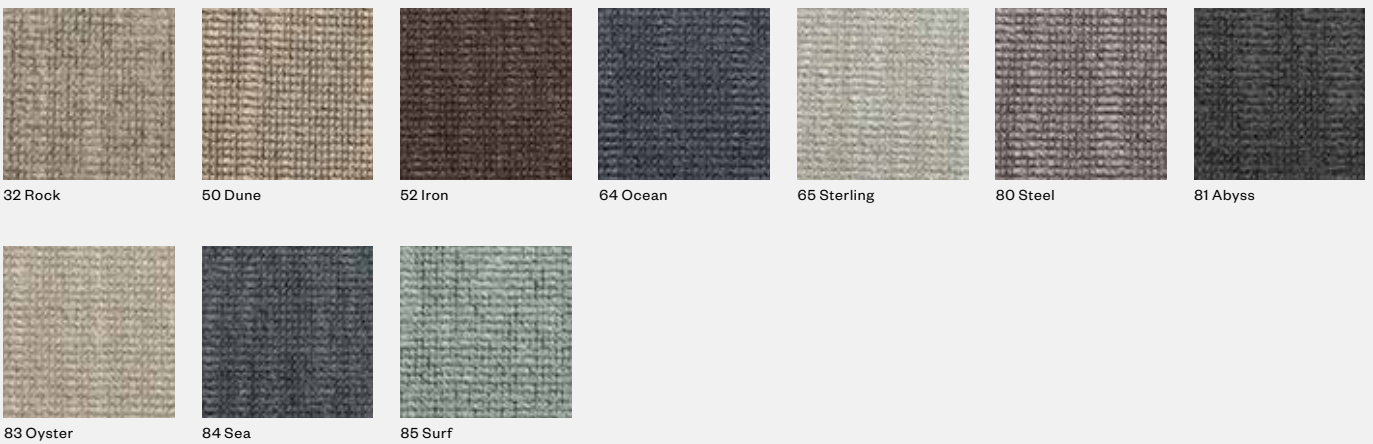

Tiempo



Apollo

Not available in all UK



31 Star



32 Moon



12 Venus



57 Sun

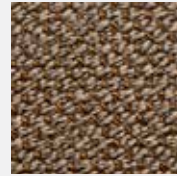

56 Earth



66 Neptune



81 Mercury



86 Pluto

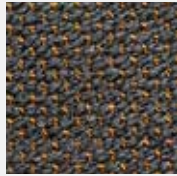

50 Jupiter

Spazio

Not available in all UK



403 Yellow



37 Beige

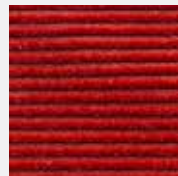

100 Red

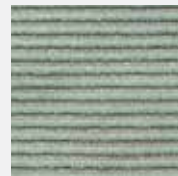

614 Light bleu

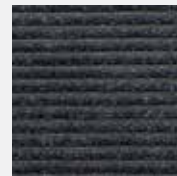

64 Dark bleu

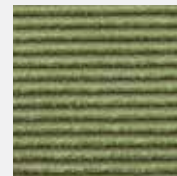

209 Green



61 Petrol



3 Black



86 Anthracite

Prairie

Not available in all international markets

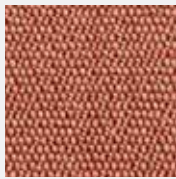

17

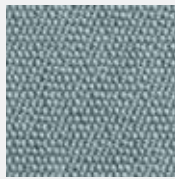

45



48



59



79

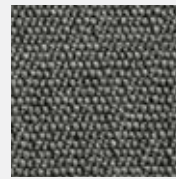

86

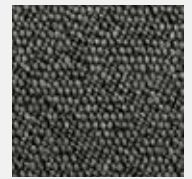

88



96

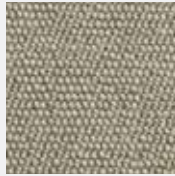

97

Lucir

Not available in all UK & USA



005 Tourmaline

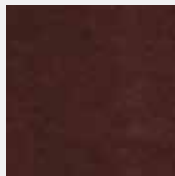

071 Ruby

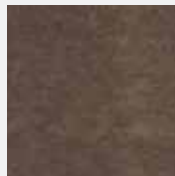

081 Zultanite



190 Calcite

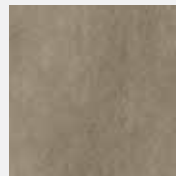

228 Agate

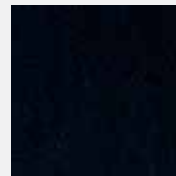

310 Lapis



380 Jade



590 Amethyst



600 Jasper

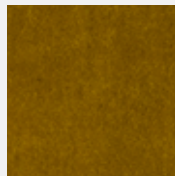

800 Topaz

Hallingdal 65

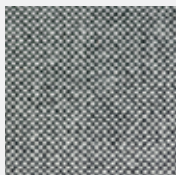

126



130

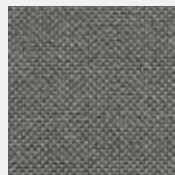

163

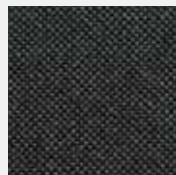

173

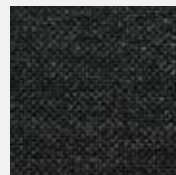

180

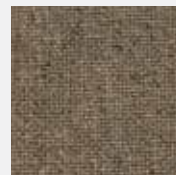

227



368



674

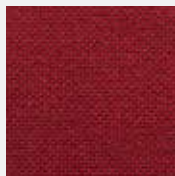

687

230

Bolster



04



18



44



66



75



80



83



84



87



88



99

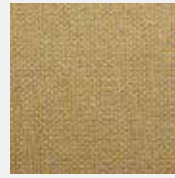

962

Varese

Not available in all UK & USA



02 Fer

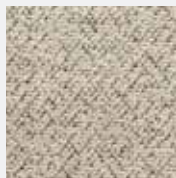

05 Blanc

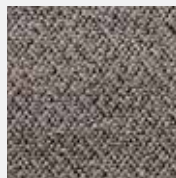

08 Raisin



10 Gris

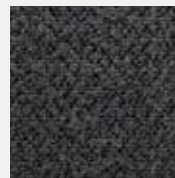

13 Bleu

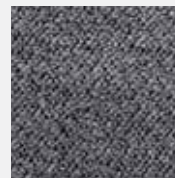

14 Inox



15 Poivre



19 Taupe



22 Angora

From a sofa to a coffee table, you can attune your new Leolux product to your taste, down to the very last detail. We offer a huge collection of materials for this so that you can shape your new pride and joy exactly as you'd like. From lacquer to epoxy colours to the most beautiful wood and most exclusive marble.

Ceramic



Basalt Noir



Béton

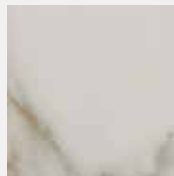

Calacatta



Iron Moss

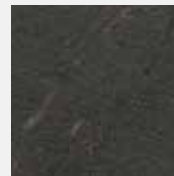

Pietra Grey

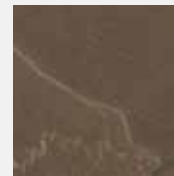

Pulpis

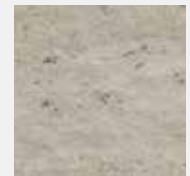

Strata Argentum

Ceramic Gloss

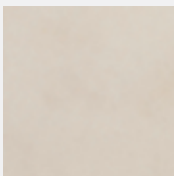

Raffaello



Frappuccino

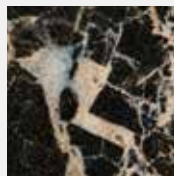

Saint Laurant

Fenix

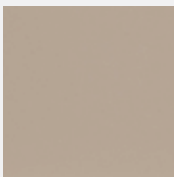

Beige-Luxor

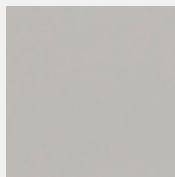

Bianco-Male

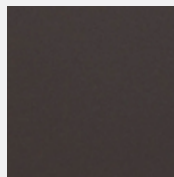

Cacao-Orinoco

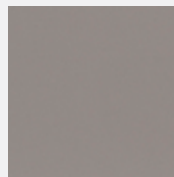

Grigio-Londra

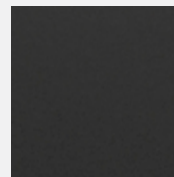

Nero-Ingo

Glass

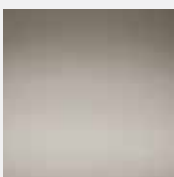

Bronze



Grey

Marble



Bianco Carrara

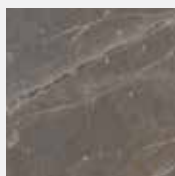

Grey Rigna



Marron Emperador

Wood — Oak

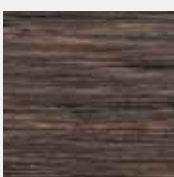

Coffee M4200

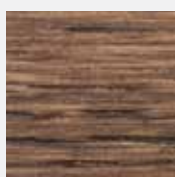

Hazel M5000

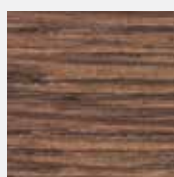

Macademia M3700

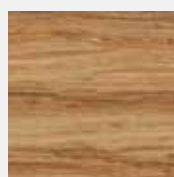

Naturel M2100

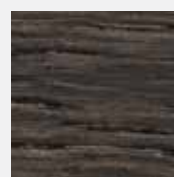

Night M4300

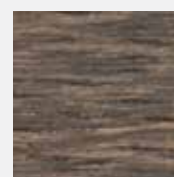

Nut M4100

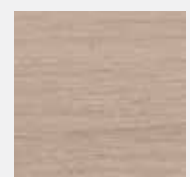

Pale White

Wood — Oak



Pinegrey M4500



Pistache M4400

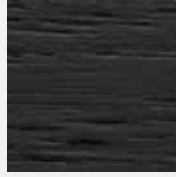

Santos M2900

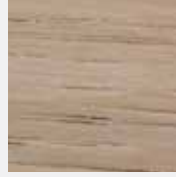

White M4000

Wood — Walnut



Naturel M2100

Epoxy



E800 Ice Silk

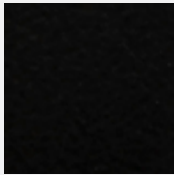

E900 Ebony Silk



E1100 Titanium Silk



E1500 Granite Matt



E1600 Basalt Matt

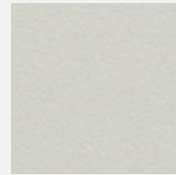

E1700 Pearl Matt



E1900 Biscotti Matt



E2000 Alfalfa Matt



E2100 Charcoal Matt

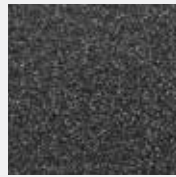

E2200 Nuit



E2300 Bronze Silk



E2500 Taupe Silk

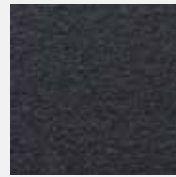

E2600 Lava Silk



E2700 Khaki Diamond



E2800 Raven Diamond



E3000 Lead Diamond



E3100 Patina Diamond



E3200 Alpaca Diamond



E3400 Silver Silk



E3500 Nickel Silk



E3600 Noctis Diamond

Cristallo



C1000 Dark Chocolate



C1100 Platinum



C1200 Steel

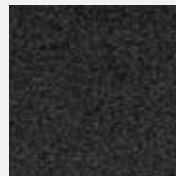

C1300 Raven



C2800 Military



C2900 Gold

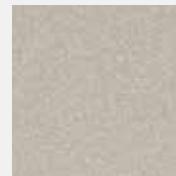

C3000 Vanilla



C3100 Eggshell



C3500 Pumice



C3600 Champagne



C4300 Alpaca

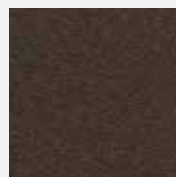

C4400 Taupe

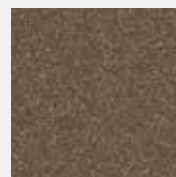

C4500 Bronze

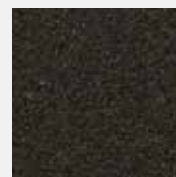

C4600 Notte

Satiné / Spruzza

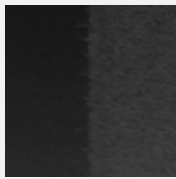

10 Black



20 Santos

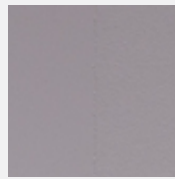

025 Spray

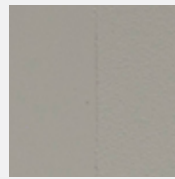

030 Dove

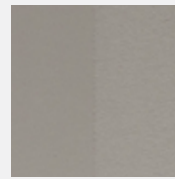

040 Pewter



050 Coal

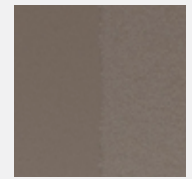

070 Taupe



80 Ivory

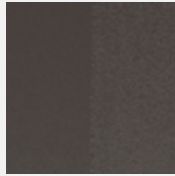

081 Cocoa



90 White

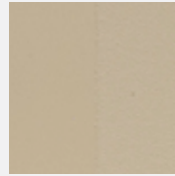

110 Ash



120 Powder

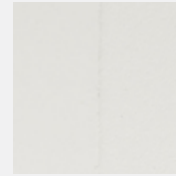

130 Lily



155 Sahara



160 Saffron



170 Kurkuma

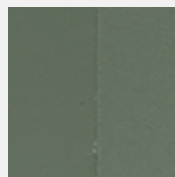

175 Thyme

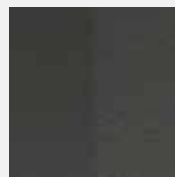

210 Carbon



286 Wave

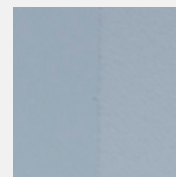

288 Air

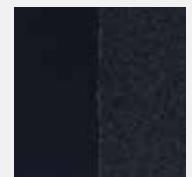

290 Eclipse



390 Cranberry



400 Pepper

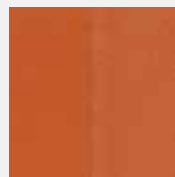

425 Minnola

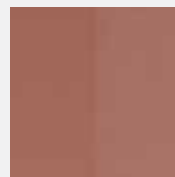

435 Cedar



Leolux Design Centers

Eindhoven (NL)

Meubelboulevard Ekkersrijt 4040
5692 DA Son
Tel.: +31 (0) 499 490 976
E-mail: eindhoven@leolux.nl

Krefeld (D)

Elbestraße 39
47800 Krefeld-Gartenstadt
Tel.: +49 (0) 2151 94 36 60
E-mail: krefeld@leolux.de

Utrecht (NL)

Beneluxlaan 27
3527 HS Utrecht
Tel.: +31 (0) 30 293 81 49
E-mail: utrecht@leolux.nl

Sint-Pieters-Leeuw (B)

Bergensesteenweg 423A
1600 Sint-Pieters-Leeuw
Tel.: +32 (0) 2 331 27 70
E-mail: info@leolux.be

Follow us on **f** facebook: @leoluxglobal
i instagram: @leoluxdesignfurniture

Text:

Ben Salden | Antal Németh

Chief editors:

Hans Filippini | Studio Truly Truly

Interviews:

Jeroen Junte

Art direction:

Studio Truly Truly

Photography:

Pim Top | René van der Hulst | Zebra Fotostudio's | Peer
Coopmans | Hugo Thomassen | Lisa Klappe

Styling:

Dennis & Did | Mira Bettin | Isabel Croon | José Martens |
Kamer 465

Photo locations

B.C. Koekkoek-Haus Kleef | Museum Van Bommel
Van Dam Venlo | Kasteel Aerwinkel Posterholt |
Villa Kerckebosch | Ateliershuur Enschede |
Bosman Family Zeist | Grace Locations

Decoration detail photography

Baars & Bloemhoff

We want to thank everyone who has contributed to the
creation of this book.

Leolux

Kazernestraat 15
5928 NL Venlo
The Netherlands
info@leolux.com www.leolux.com



Verband der Deutschen
Polstermöbelindustrie e.V.

Member of Association of German
upholstery manufacturers

© 2020 Leolux. Nothing from this publication may be
copied or reprinted without written permission from
Leolux Living B.V.

Printing and typographical errors reserved.

Colours may vary for typographical reasons.

Leolux Global BV
Kazernestraat 15
PO Box 3076
5902 RB Venlo
The Netherlands
T +31 (0) 77 38 77 222
E export@leolux.nl

More information about our partners, prices,
upholsteries and the Leolux warranty:
www.leolux.com



leolux