



Furniture



TAVOLI / TABLES
 CONSOLLE / CONSOLES
 SCRITTOI / DESKS



01_Alice
p.15



02_Atlantis
p.21



03_Babar
p.31



04_Bisel
p.45



05_Boxinbox
p.55



06_Calice
p.63



07_Collector
p.69



08_Compression
p.75



09_Crack
p.85



10_Crossing
p.91



11_Deep Sea
p.103



12_Diapositive
p.109



13_Doble
p.115

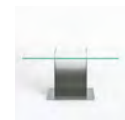

14_Donald
p.123



15_Don Cavalletto
p.135



16_Don Gerrit
p.141



17_Float
p.151



18_Folio
p.157



19_Fountain
p.163



20_Funghetti
p.171



21_Glass Table (1976)
p.177



22_Harold and Maude
p.183



23_Hub
p.189



24_Hub Cut
p.199



25_I-Beam
p.205



26_Illusion
p.211



27_I Massi tavoli bassi
p.217



28_Kazmir
p.223



29_Kooh-I-Noor tavoli
p.231



30_Lazy Hub
p.237



31_L.A. Sunset
p.247



32_Liquefy
p.253



33_Mari Cristal
p.263



34_Metal
p.269



35_Mirror Mirror
p.275



36_Nacre
p.285



37_Nesting
p.291



38_Ollie
p.297



39_Oscar
p.305



40_Pipeline
p.311



41_Pirandello
p.317



42_Plissé
p.323



43_Post Modern
p.329



44_PRISM mirror table
p.335



45_Ratio
p.345



46_Remis
p.351



47_Robotin
p.359



48_Seasons
p.367



49_Shimmer
p.373



50_Simoon
p.385



51_SiO₂-Bridge
p.399



52_SiO₂-Tunnel
p.405



53_Specchio di Venere
p.411

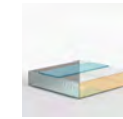

54_Spectrum
p.421



55_Strata
p.429



56_Terraliquida
p.435



57_The Dark Side of the Moon Striped / Faded
p.441



58_Verglas
p.451



59_Wireframe
p.457



60_X-T
p.463



61_XX
p.471



62_XXX
p.477

SEDUTE / SEATS



63_ Bent Glass Bench
Bent Glass Stool
p.483



64_ Crystal Lounge
p.489



65_ Crystal Stool
p.497



66_ Diapositive
p.503



67_ I-Beam
p.509



68_ Merci Bob
p.515



69_ PRISM glass chair
p.521



70_ Tête-à-tête
p.525



71_ Triennale
p.533

CONTENITORI / STORAGE UNITS LIBRERIE / BOOKCASES VETRINE / DISPLAY CASES



72_ Ami-verre
p.537



73_ Boxinbox
p.55



74_ Collector
p.545



75_ Commodore
p.551



76_ Deep Sea P.
p.557



77_ Dr Jekyll and Mr Hyde
p.561



78_ Drift
p.567



79_ Float
p.575

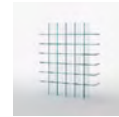

80_ Glass shelves #1 (1976)
p.581



81_ Heigh-Ho
p.587



82_ Layers
p.593



83_ Magic Box
p.599



84_ Mandarin
p.609



85_ Obliquo
p.619



86_ Ollie
p.627



87_ Oltralpe
p.633



88_ PRISM glass wardrobe
p.641



89_ Quantum
p.647



90_ Robotin
p.655



91_ Space
p.661



92_ Transfix
p.665



93_ Wunderkammer
p.669

SPECCHI / MIRRORS



94_ Andromeda (1974)
p.677



95_ Bric
p.689



96_ Brillante
p.695



97_ Celeste
p.701

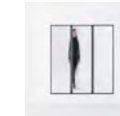

98_ Como
p.707



99_ Cosmos
p.717



100_ Diva
p.723



101_ Ecco
p.729



102_ Etrusco
p.735



103_ Fiction
p.741



104_ Giano
p.747

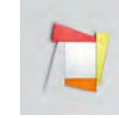

105_ Gli Specchi di Dioniso
p.753

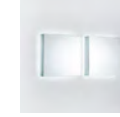

106_ I Massi specchi
p.765



107_ Kooh-I-Noor specchi
p.769



108_ Leon Battista
p.775



109_ Lesena
p.781



110_ Maestrale
p.785



111_ Mandala
p.793



112_ Marlene
p.799



113_ Menteur
p.807

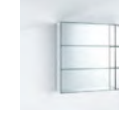

114_ Mirror Mirror
p.815



115_ Onda
p.821



116_ Palanco
p.825



117_ PRISM mirror specchi
p.831



118_ Rokokó
p.837

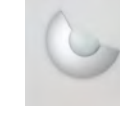

119_ Scornice
p.847



120_ Scribble
p.853



121_ Settecento
p.861



122_ Shibam 1
p.867



123_ Shibam 2
p.873



124_ Shimmer specchi
p.879



125_ Specchio di Proust
p.889



126_ Spizzo
p.895



127_ Sturm und Drang
p.901



128_ Sybilla
p.907

COMPLEMENTI / COMPLEMENTS



129_ Angelo e Angela
p.913



130_ Fragment *paravento*
p.919



131_ PRISM *partition*
p.925



132_ Rayures
p.935



133_ Telegrafo
p.943



134_ Transformer
p.949



135_ Tutube
p.955

MENSOLE / SHELVES



136_ Everywhere
p.961



137_ Kazmir
p.967



138_ Light-Light
p.975



139_ On
p.981

TAVOLI / TABLES
CONSOLLE / CONSOLES
SCRITTOI / DESKS



■ ← INDEX

Serie di tavoli bassi a forma di parallelepipedo in cristallo fumè 6 mm temperato, incollato a 45°, al cui interno è contenuta una complessa struttura a nido d'ape. Quattro piedini cromati sollevano leggermente il volume da terra. Disponibili in due differenti misure.

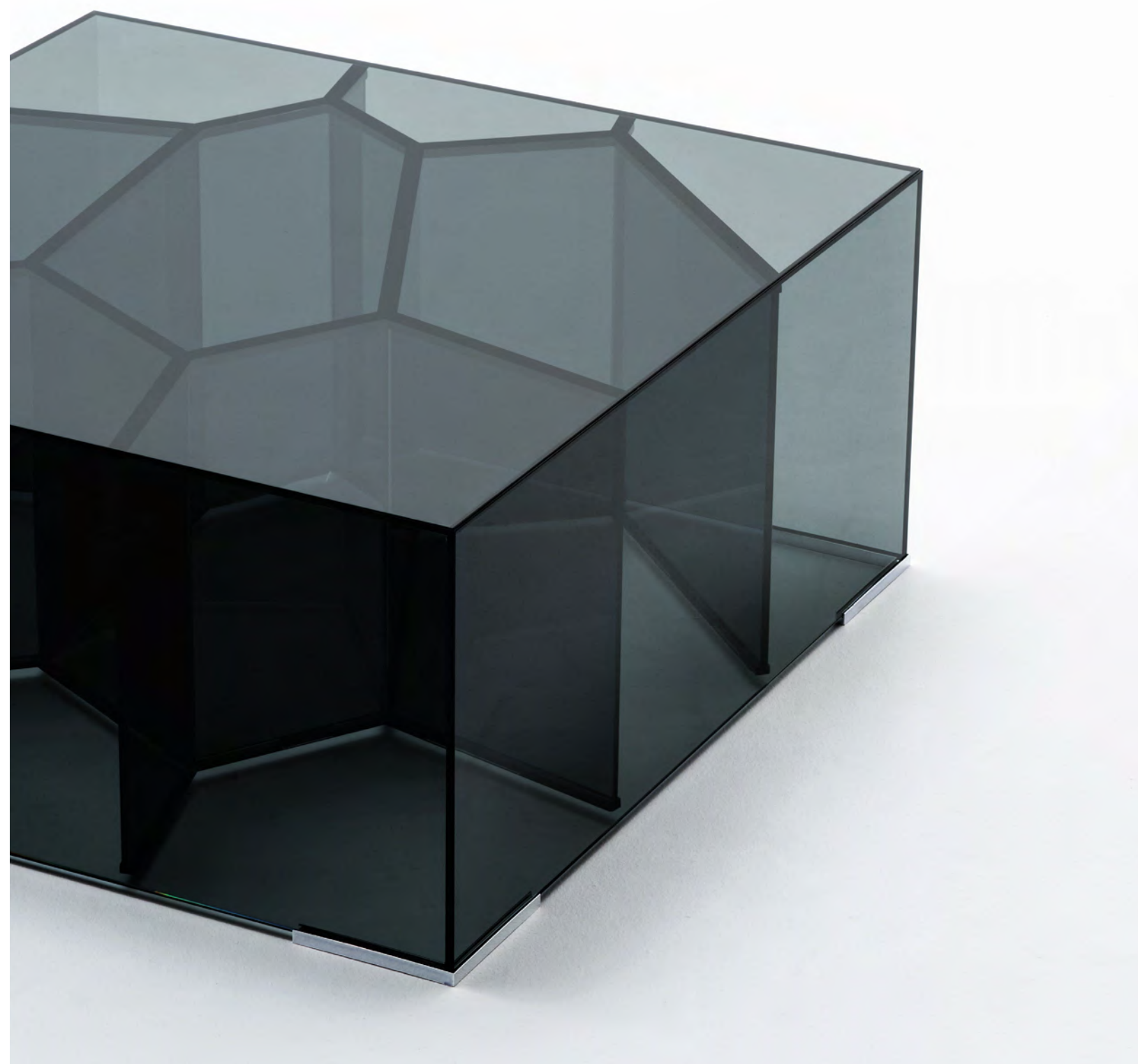

Dimensioni:

ALI01 L 60 P 60 H 27

ALI02 L 50 P 50 H 45



Series of parallelepiped shaped low tables in 6 mm tempered smoked glass, glued 45°, to which inside contains a complex honeycomb structure. Four little chromium-plated feet slightly raise up the volume from the ground. Available in two different sizes.





INDEX ←





Serie di tavoli alti realizzati incollando lastre di cristallo 8 mm temperato, tagliato a getto d'acqua e molato a 45°. Disponibili in cristallo trasparente extralight o laccato lucido. La purezza formale, la sobrietà e le sofisticate tecniche di lavorazione sono le caratteristiche principali di questo tavolo.

Finiture: cristallo trasparente extralight / cristalli laccati lucidi

Dimensioni:

TAA02 L 130 P 130 H 74
TAA03 L 200 P 90 H 74

TAA05 L 180 P 180 H 74
TAA07 L 250 P 100 H 74

Series of high tables obtained by glued 8 mm thick tempered glass plates, cut with water jet and with 45° chamfered edge. Available in extralight transparent glass or glossy lacquered glass. The formal purity, the sobriety and the sophisticated craftsmanship are the main features of this high table.

Finishes: transparent extralight glass / glossy lacquered glass







Serie di tavoli bassi realizzati incollando lastre di cristallo 6 mm temperato, tagliato a getto d'acqua e molato a 45°. Disponibili in cristallo trasparente extralight o laccato lucido. La purezza formale, la sobrietà e le sofisticate tecniche di lavorazione sono le caratteristiche principali di questo tavolo.

Finiture: cristallo trasparente extralight / cristalli laccati lucidi

Dimensioni:

TAT05 L 140 P 80 H 36

TAT07 L 80 P 80 H 36

TAT06 L 120 P 60 H 36

TAT08 L 110 P 110 H 36

Series of low tables realized by glued 6 mm thick tempered glass plates, cut with water jet and with 45° chamfered edge. Available in extralight transparent glass or glossy lacquered glass. The formal purity, the sobriety and the sophisticated craftsmanship are the principal characteristics of this table.

Finishes: extralight transparent glass / glossy lacquered glass







← INDEX



Serie di tavoli alti, tavoli bassi e consolle di forma rotonda e ovale, realizzati in una speciale graniglia di vetro riciclato al 100%, legata da polimeri con componenti d'origine vegetale e ottenuti da fonti rinnovabili. Ogni pezzo, realizzato a mano, si caratterizza per superfici e geometrie irregolari, per un aspetto organico, unico e irripetibile. Le gambe sono facilmente assemblabili e smontabili grazie ad un comodo sistema di piastre metalliche. Disponibile in cinque diverse colorazioni, sempre leggermente variabili e disomogenee: ghiaccio, giada, argilla, miele e lavanda.

Dimensioni:

BAB01	ø 42	H 51	BAB06	ø 140	H 74	
BAB02	ø 42	H 41	BAB07	ø 150	H 74	
BAB03	ø 100	H 41	BAB08	ø 160	H 74	
BAB04	ø 120	H 41	BAB09	L 200	P 100	H 74
BAB05	ø 130	H 74	<i>ovale</i>			
			BAB10	L 130	P 45	H 74
			<i>consolle</i>			

Series of round and oval high tables, low tables and console, made of a special 100% recycled glass grit, blended with polymers partly of plant origin and obtained from renewable sources. Each piece is hand-made and characterized by an irregular surface and geometry, featuring an organic and unique appearance. The legs are easily assembled and dismantled thanks to a practical system of metal plates. Available in five different colours, always slightly variable and not homogeneous: ice, jade, clay, honey and lavender.













INDEX ←



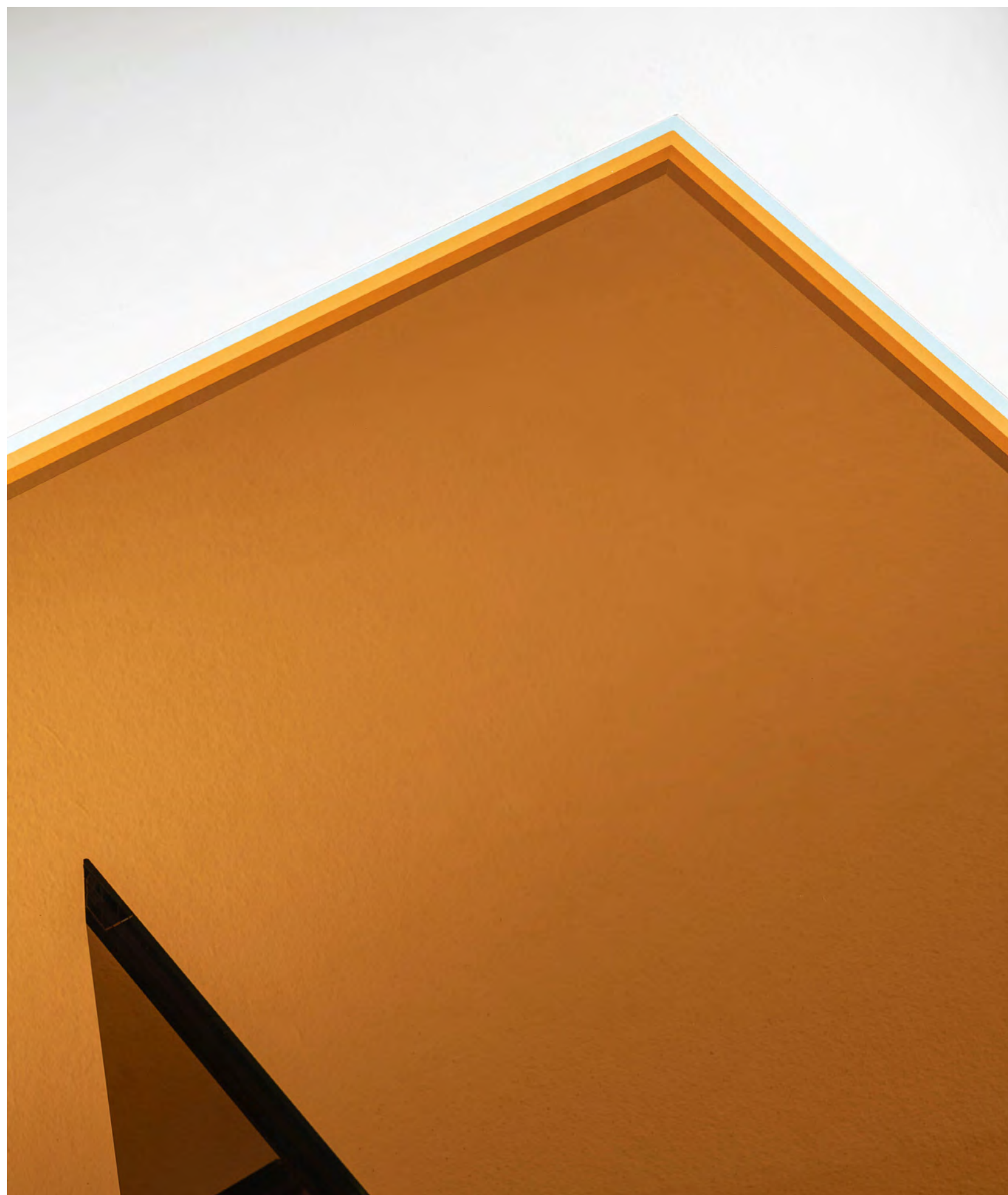

Collezione composta da tavoli alti, tavoli bassi e consolle, realizzati in cristallo multistrato e multi-cromatico, ottenuto stratificando cinque lastre di cristallo extralight 5 mm con pellicole di diversi colori. Le lastre ottenute vengono sagomate in diverse forme, molate filo lucido e sfaccettate grazie ad importanti bisellature che fanno emergere in trasparenza le meravigliose e variegata colorazioni del materiale. I vari componenti vengono poi saldati tra di loro in totale purezza, grazie a speciali tecniche di incollaggio, dando forma così a preziosissimi gioielli d'arredo. Disponibili nelle finiture verde o ocra.

Dimensioni:

BIS01 L 100 P 91 H 40
BIS02 L 60 P 35 H 50

BIS03 L 119 P 42 H 80
BIS04 L 220 P 90 H 72

Collection of high tables, low tables and console, made in multi-layered and multichromatic glass, created by laminating five slabs of 5 mm extralight glass each with a different coloured film. The obtained glass sheets are in different shapes, shiny ground polished and "faceted" by means of unique bevels accentuating through the transparency of the glass the stunning multi-coloured material. The different components are then welded together in total clarity, by means of a special gluing technique, so creating very precious "furniture jewels". Available in green or ochre finish.





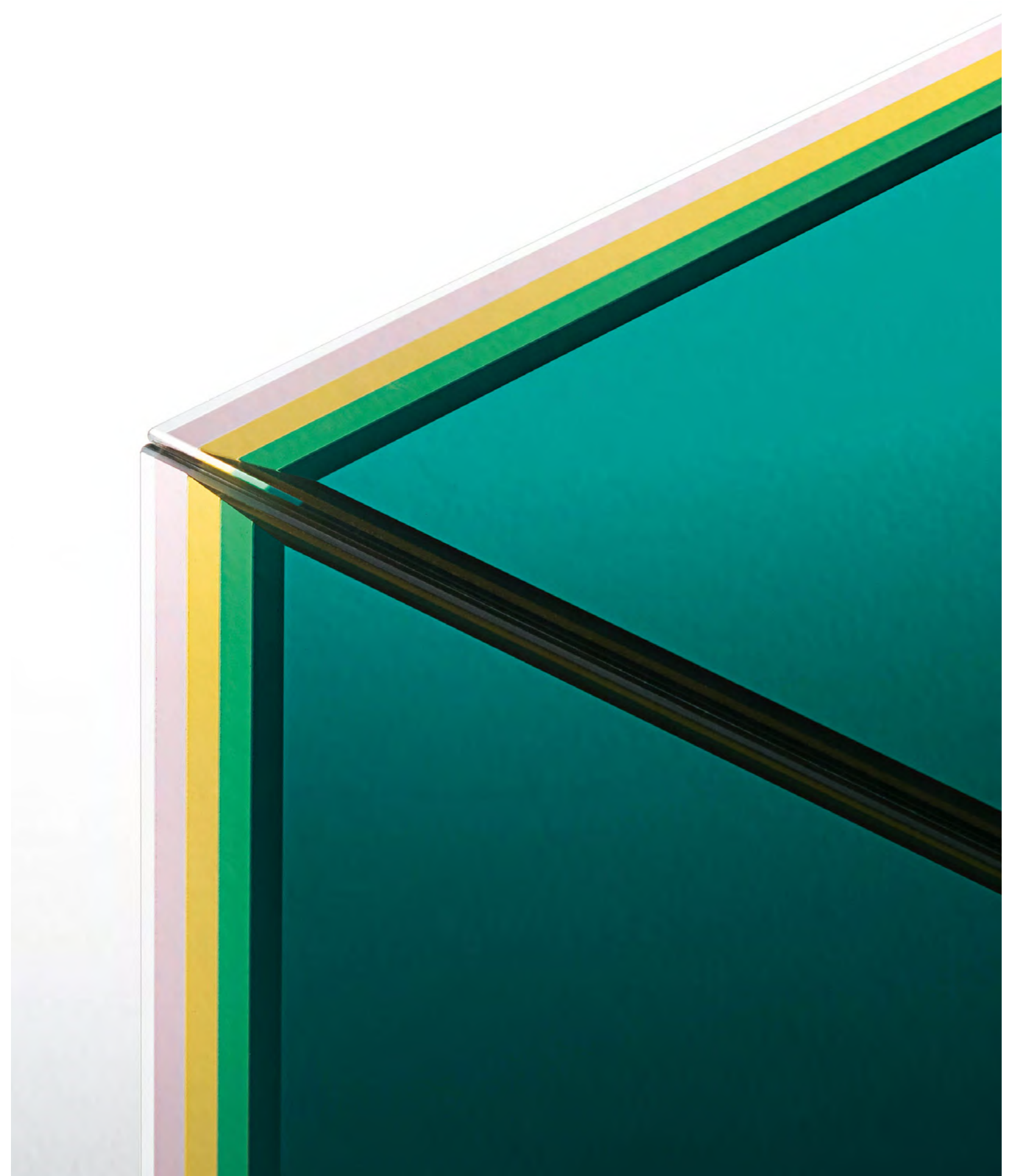





INDEX ←



Serie di tavolini, contenitori e mobili a giorno concepiti come scatola nella scatola. Realizzati in cristallo extralight stratificato 5+5 mm termosaldato e posizionati su basi in acciaio inox lucidato a specchio. Un volume in cristallo trasparente extralight incollato a 45° racchiude e valorizza un secondo elemento con funzione di contenimento, disponibile in cristallo trasparente colorato. Fa parte della collezione anche un tavolino-archivio a sei ripiani in cristallo stratificato 5+5 mm nelle stesse colorazioni sopra descritte. Anch'essi termosaldati e con basamento in acciaio inox lucidato a specchio. La collezione è completata da funzionali scatole porta oggetti, disponibili in due varianti: impagliate a mano con fibra vegetale o in legno di zebrano con giunzioni a coda di rondine.

Finiture: cristalli trasparenti colorati

Dimensioni:

BIB01 L 85 P 36,5 H 90
BIB02 L 40 P 36,5 H 166
BIB03 L 85 P 36,5 H 166
BIB04 L 95 P 60 H 38

BIB05 L 40 P 36,5 H 60
BIB08 L 93 P 70 H 41,5

DRW01 L 64 P 30 H 20 *scatola porta oggetti / objects storage case*

DRW02 L 30 P 20 H 20 *scatola porta oggetti / objects storage case*

A series of low tables and closed and open storage furniture, designed like a box within a box, in laminated 5+5 mm thermo-welded extralight glass. These are placed on a base of reflective polished stainless steel. A space within the transparent extralight glass unit glued at 45° allows a second element with storage function available in transparent coloured glass. In the collection there is also low storage table with six shelves in laminated 5+5 mm glass in the same above-described colouring. Also these ones are thermowelded and have a base in reflective polished stainless steel. The collection is completed by functional objects storage cases, available in two versions: hand-caned with vegetal fiber or in zebrano wood with dovetail joints.

Finishes: transparent coloured glass

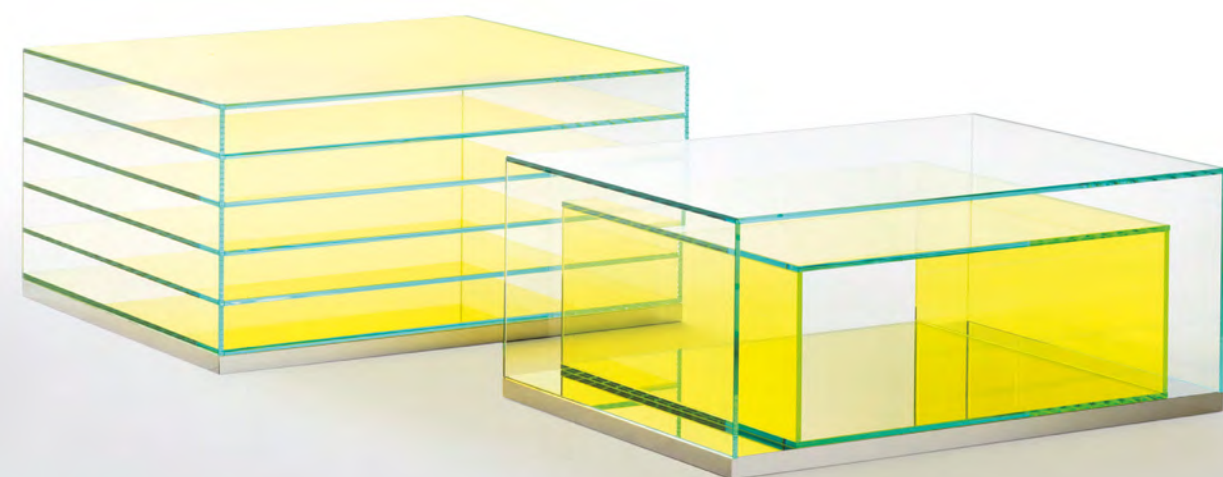

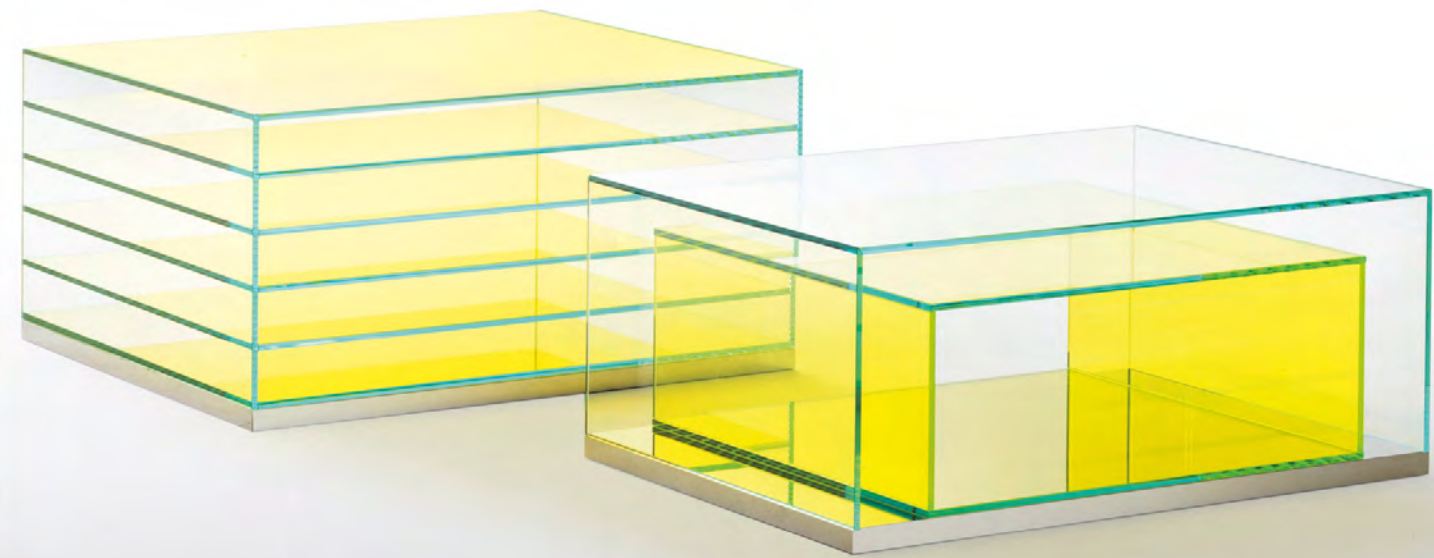





INDEX ←



Tavolini rotondi disponibili in due altezze con piano e piede in cristallo 8 mm temperato laccato lucido. Il basamento è in cristallo soffiato sagomato, con decorazioni incise sulla superficie.

Finiture: cristalli laccati lucidi

Dimensioni:

CAL01 ø 50

H 30

CAL02 ø 50

H 44



Round low tables available in two heights with top and foot in tempered 8 mm thick glossy lacquered glass. The base is in shaped blown glass, with decorations engraved on the surface.

Finishes: glossy lacquered glass





← INDEX





Collezione di tavolini - espositori e vetrine con fianchi e top in cristallo trasparente extralight 8 mm. I fianchi sono curvati in modo da combaciare con la sagomatura del top, a cui sono incollati. Le vetrine, con ferramenta in alluminio anodizzato nero, sono provviste di un ripiano. Le basi sono in massello di frassino laccato nero poro aperto e, solo nei tavolini, con uno specchio incassato a filo. All'interno delle vetrine (COR03 - COR06) si accede per mezzo di ante, mentre nei tavolini grazie allo scorrimento di due frontalini.



Dimensioni:

COR01 L 130 P 70 H 34

COR02 L 110 P 110 H 34

COR03 L 120 P 40 H 85

COR06 L 120 P 40 H 120



Collection of low tables and display units with sides and top in transparent extralight 8 mm glass. The sides are curved to fit the shape of the top, to which they are attached. The display units are supplied with hardware in black anodized aluminium and a shelf. The bases are in solid open pore black lacquered ash and, for the low tables only, they have a flush recessed mirror. The display units (COR03 - COR06) have doors, while the low tables have two sliding front parts.



*Comme l'eau et le feu,
le mariage du verre
et du bois
lors d'un miracle
technologique.*

P.S.



■ ← INDEX

**Dimensioni:**

COMP01	L 220	P 90	H 74	COMP04	L 220	P 100	H 74
COMP02	L 240	P 90	H 74	COMP05	L 240	P 100	H 74
COMP03	L 250	P 90	H 74	COMP06	L 250	P 100	H 74

Serie di tavoli da pranzo rettangolari con piano in cristallo trasparente 19 mm e base in cristallo trasparente 24 mm temperato. Una trave, in un unico massello di grosso spessore, passa attraverso i fori - a filo lucido inclinato - dei cristalli della base, unendoli e sostenendoli. Dei cunei in metallo cromato lucido si inseriscono ad incastro nei fori rastremati presenti sulla trave in legno, bloccando saldamente le lastre di cristallo della base e conferendo alla stessa massima stabilità e solidità. La trave, in massello di rovere, è disponibile in due finiture naturali: con spazzolatura profonda e finita a cera, oppure carbonizzata per mezzo di un trattamento termico. I piedini e i supporti delle basi e del piano sono in metallo cromato lucido.

Series of rectangular dining tables with 19 mm transparent glass top and 24 mm tempered transparent glass base. A beam, made of a single thick wooden piece, passes through the inclined edged holes of the glass base sheets, uniting and supporting them. Polished chromed metal wedges are inserted into the tapered holes on the wooden beam, firmly holding the glass sheets of the base and giving the table maximum stability and solidity. The beam, in solid oak, is available in two natural finishes: deeply brushed and wax finished or charred through a heat treatment. The feet and top supports are in polished chromed metal.



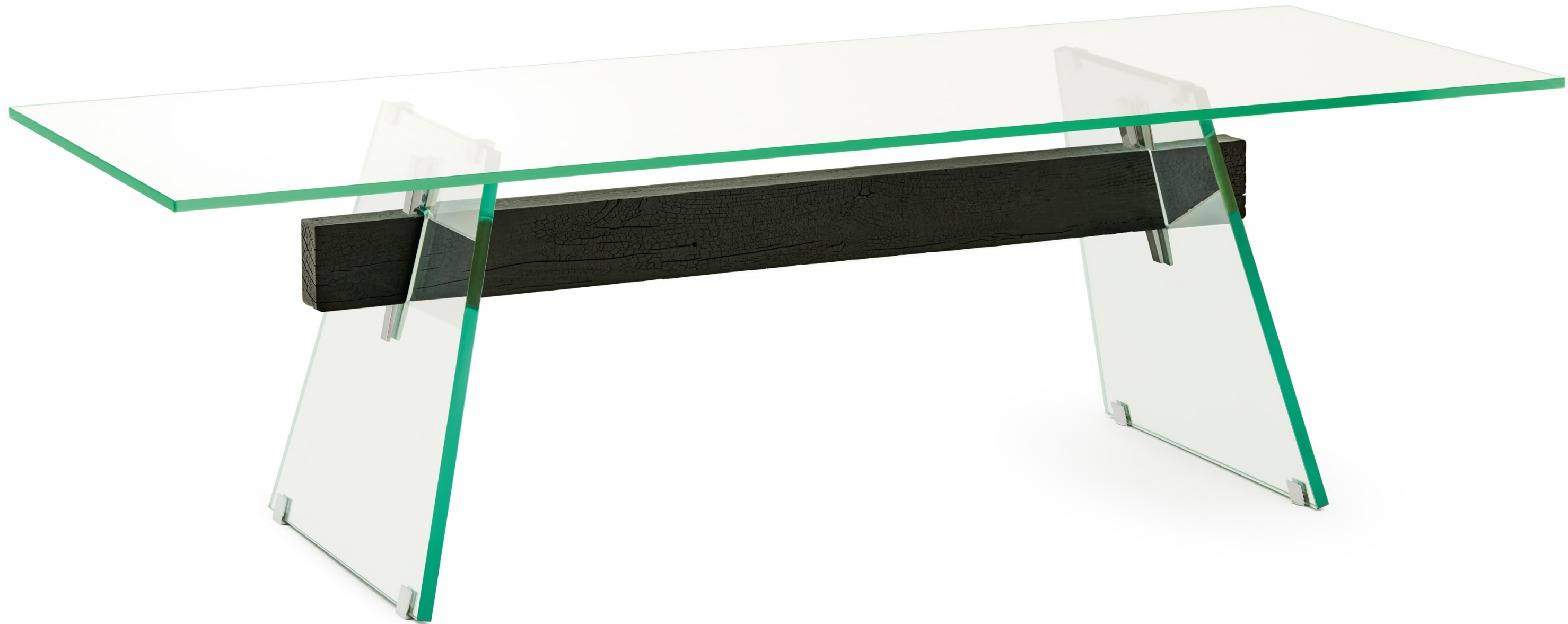

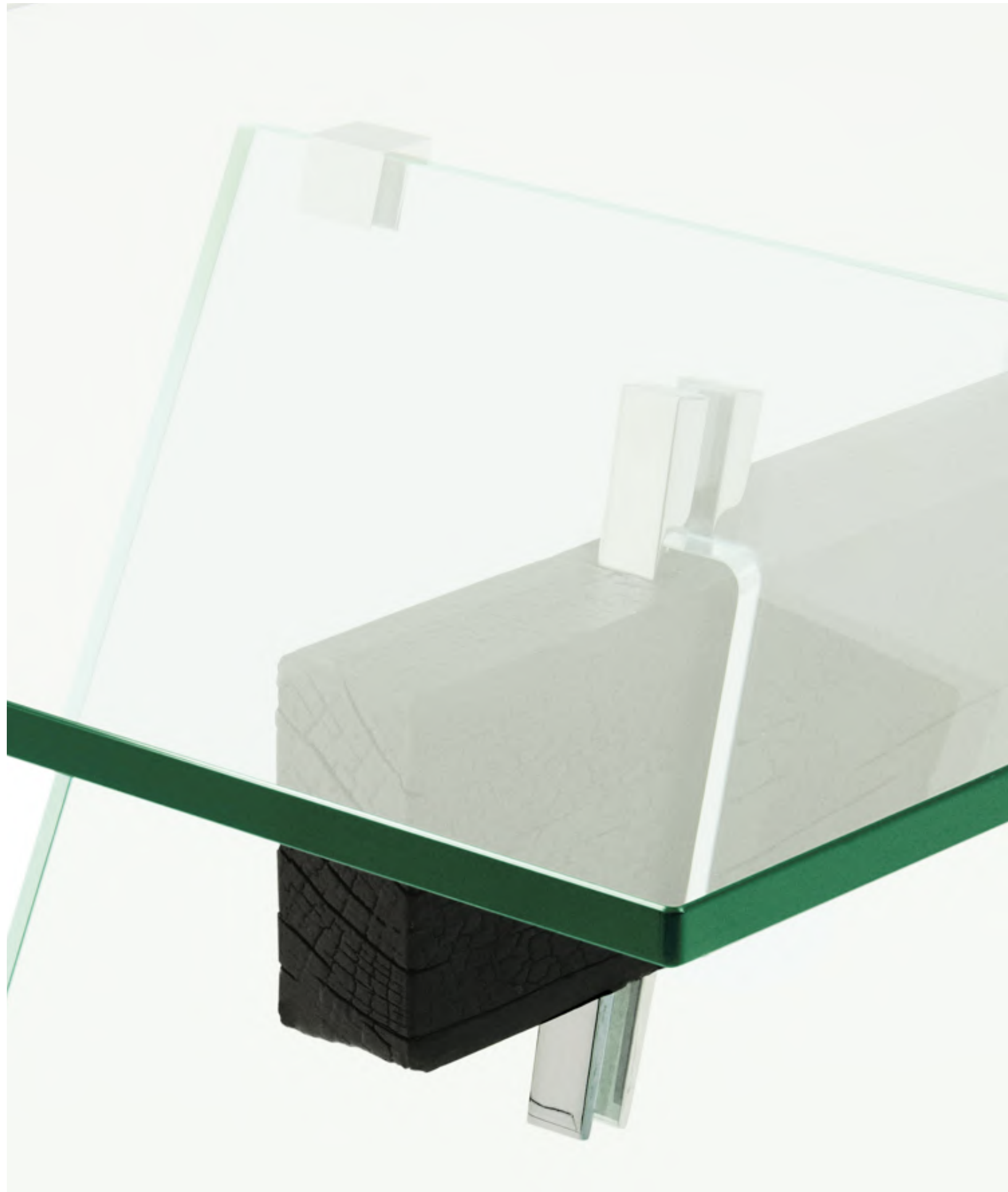



INDEX ←



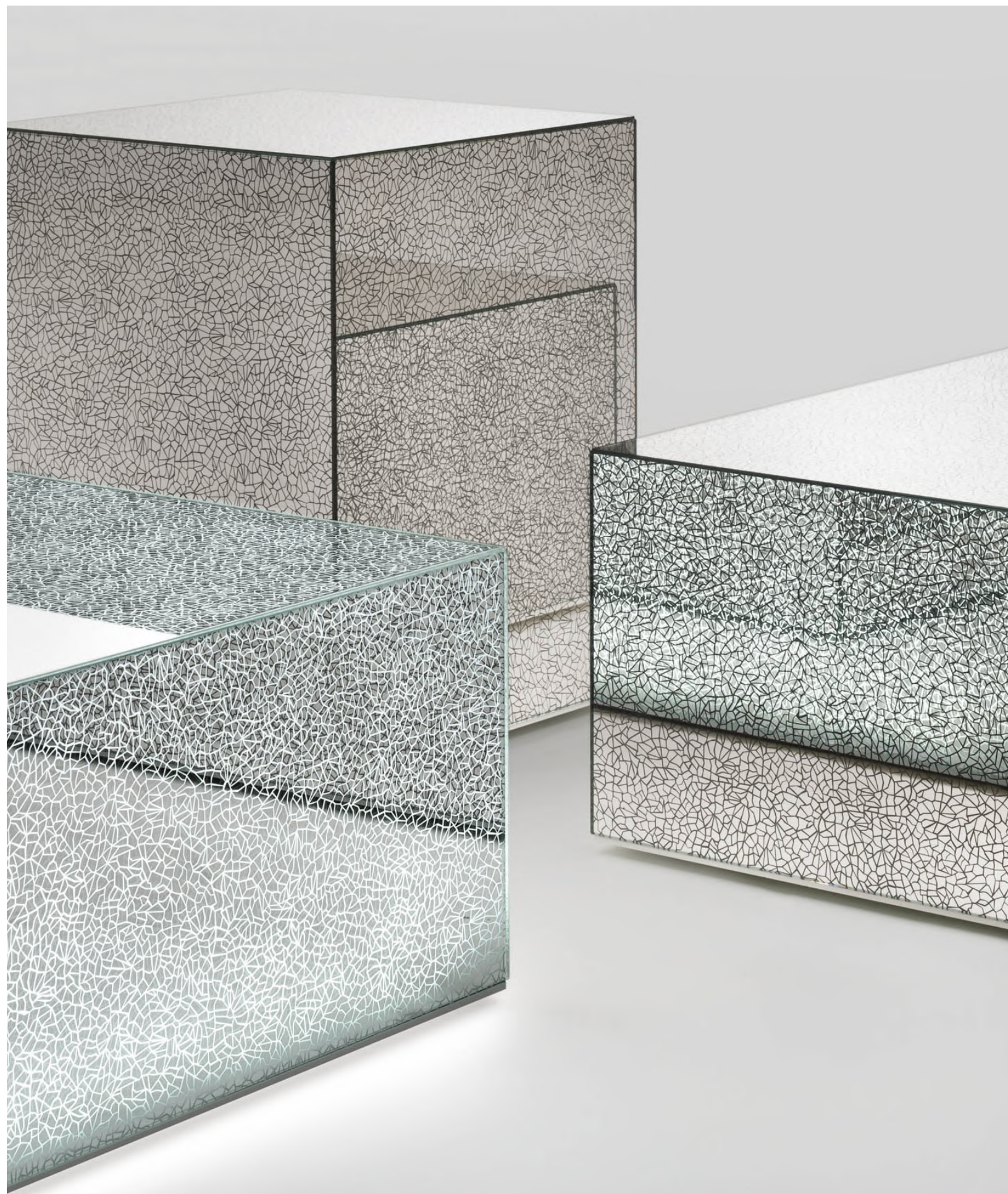

Serie di tavoli bassi con luce dimmerabile a forma di parallelepipedo in cristallo incollato a 45°, il cui decoro riproduce uno specchio esploso in tanti piccoli frammenti separati da sottili linee luminose bianche.

Dimensioni:

CRA01 L 40 P 40 H 41
CRA02 L 40 P 40 H 51

CRA03 L 70 P 70 H 31
CRA04 L 130 P 70 H 31

Collection of low tables with dimmer light with parallelepiped shape, in glass glued 45°, with shattered mirror effect decoration separated by thin white luminous lines.



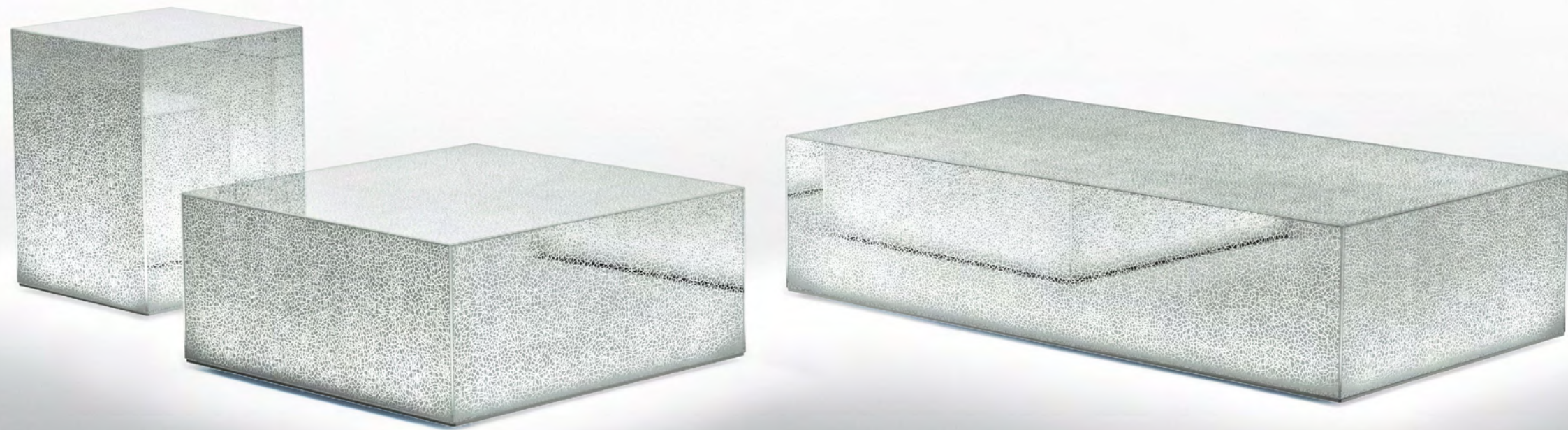



INDEX ←



Tavoli alti e bassi con piano in cristallo trasparente extralight stratificato che, grazie ad uno speciale decoro policromatico tridimensionale, presenta un magico motivo di intrecci e sovrapposizioni di linee e colori. La percezione di questo decoro cambia continuamente al variare del punto di osservazione. Tramite un particolare procedimento di stratifica, i cristalli vengono assemblati sovrapposti in posizione sfalsata, rafforzando così la dinamica dell'effetto grafico. Le basi, dalla forma irregolare, sono in cristallo trasparente extralight stratificato, incollato e decorato come il piano. Piano e basi si integrano perfettamente dando forma ad un'opera di grande forza e personalità. Sia il tavolo alto sia quello basso sono disponibili in due misure e in due varianti di decoro.



Dimensioni:

CRO01 L 246 P 92 H 74
CRO02 L 200 P 92 H 74

CRO03 L 142 P 60 H 31
CRO04 L 54 P 62 H 42



High and low tables in laminated transparent extralight glass, which thanks to special three-dimensional polychromatic decoration presents a magical pattern of weaving and overlapping lines and colours. The perception of this decoration changes continuously depending on the vantage point. By means of a particular laminating process, the crystal glass is assembled and overlapped irregularly, reinforcing the dynamics of the graphic effect. The bases, with an irregular shape, are in laminated transparent extralight glass which is glued and decorated like the top. The top and base blend perfectly creating a work of great strength and personality. Both the high table and the low one are available in two sizes and in two versions of decoration.

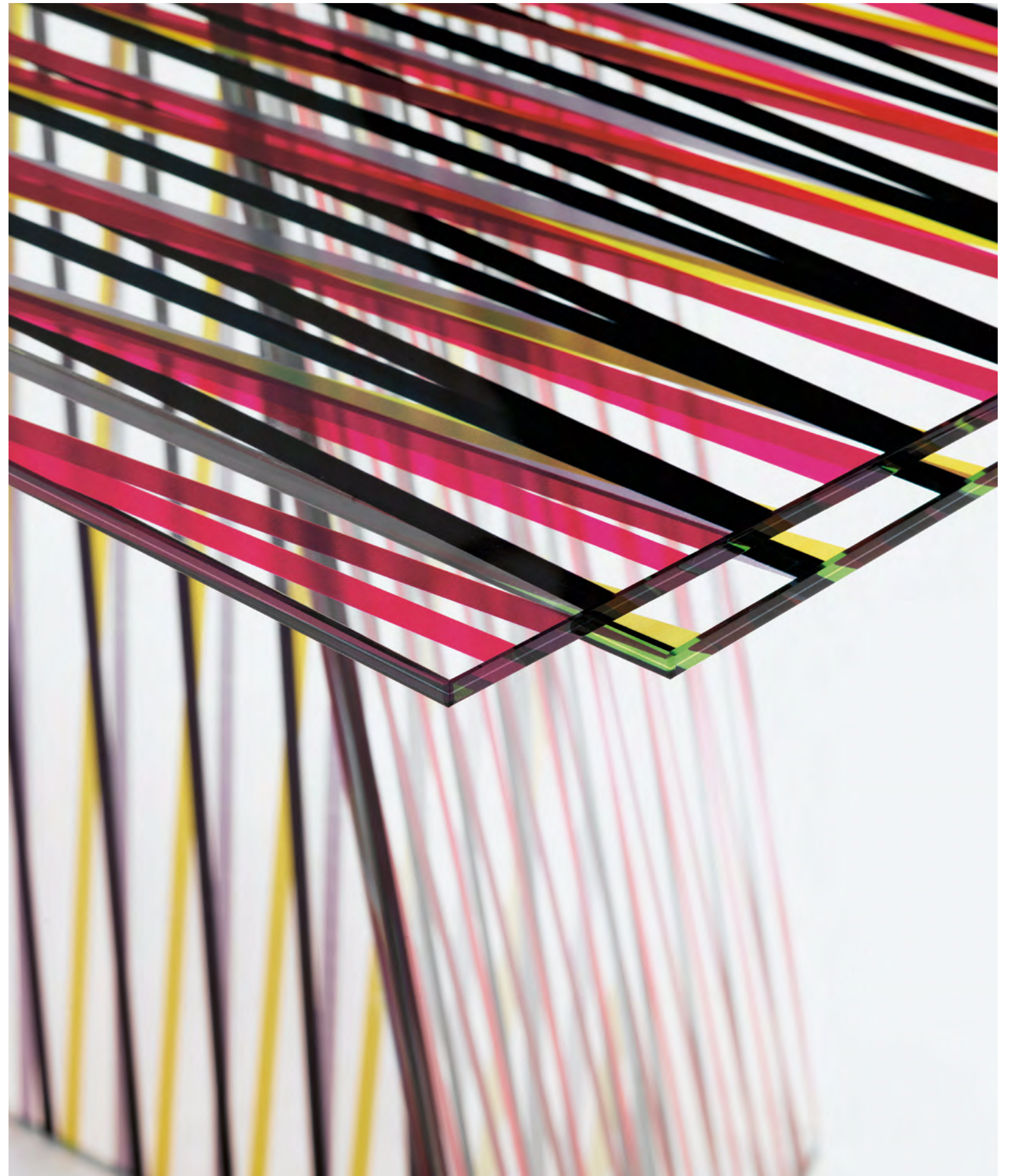





INDEX



Collezione di tavoli bassi e libreria in cristallo trasparente extralight stratificato e termosaldato. I ripiani della libreria e gli elementi verticali dei tavolini sono in cristallo trasparente colorato nei toni del grigio o dell'azzurro. Passando da un elemento all'altro, la distanza tra gli stessi diminuisce gradualmente, mentre l'intensità del colore diventa sempre più carica. Questo effetto cromatico, associato alle basi in specchio, conferisce ai pezzi grande profondità e un gioco di magici riflessi.



Dimensioni:

DEE01 L 75 P 75 H 37
tavolino / low table
DEE02 L 125 P 48 H 37
tavolino / low table

DEE03 L 75 P 35 H 151
libreria / bookcase



Collection of low tables and bookcase in laminated and thermo-welded transparent extralight glass. The shelves of the bookcase and the vertical elements of the low tables are in coloured transparent glass available in grey or blue tone. Moving from one element to the next, the distance between them gradually decreases, whilst the intensity of colour increases. This chromatic effect, associated with the mirror bases, bestows great depth to the pieces and a play of magical reflections.

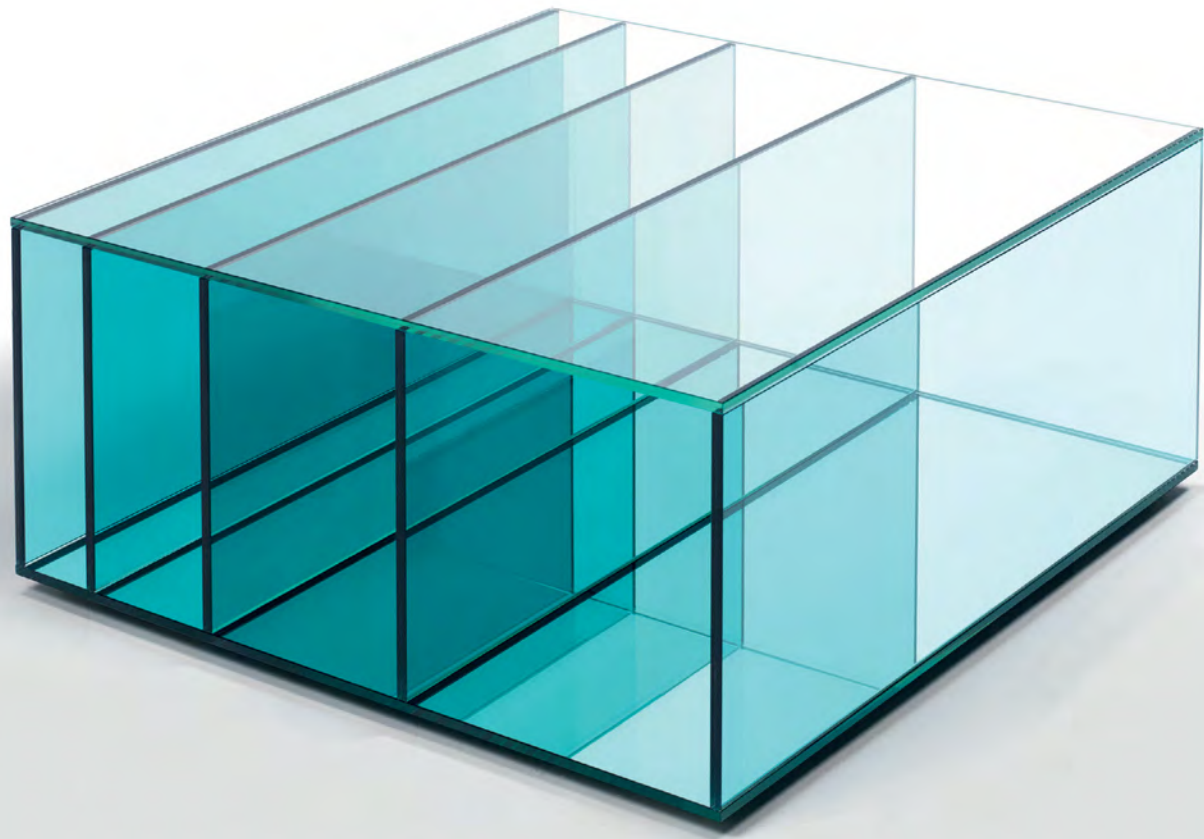



INDEX ←





Dimensioni:

DIA01 L 141 P 53 H 74

DIA02 L 141 P 53 H 114

DIA03 L 101 P 53 H 161

DIA04 L 101 P 53 H 124

DIA05 L 141 P 44 H 84

DIA06 L 130 P 43

feltro per sedute / upholstery for seats

DIA07 L 70 P 51

sovrappiano per scrittoi / overtop for desks

Collezione composta da panca, divanetto, scrittoi e piccola libreria in cristallo extralight stratificato e termosaldato, con elementi in massello di frassino naturale o rovere moro fissati alle estremità delle spalle portanti. È disponibile una versione monocromatica in vetro trasparente nelle possibili seguenti finiture: extralight, grigio chiaro, grigio scuro, lilla o rosso Siena. Vi è inoltre una seconda versione bicromatica, sempre in vetro trasparente, declinabile in due possibili combinazioni:

a) schienale rosso Siena, spalle e piani/seduta grigio chiaro.

b) schienale lilla, spalle e piani/seduta extralight.

La panca è disponibile solo nella variante monocromatica. Le sedute sono fornite con un cuscino di feltro nero o grigio mélange da 12 mm di spessore. Sui piani degli scrittoi è posizionato un pannello in legno di frassino naturale o rovere moro. La libreria e gli scrittoi sono disponibili con foro passacavi.

Collection comprising a bench, sofa, desks and small bookcase in transparent extralight, laminated and thermo-welded glass with elements of solid natural ash or dark brown oak at the outer edges of the supporting sides. A monochromatic version is available in transparent glass in the following finishes: extralight, clear grey, dark grey, lilac or sienna red. There is also a second version in two colours, still in transparent glass, available in two different combinations:

a) sienna red back, clear grey sides, top/seat.

b) lilac back, extralight sides and top/seat.

The bench is available only in the monochromatic version. The seats are supplied with a cushion in black or mélange grey 12 mm thick felt. A panel in natural ash wood or in dark brown oak lays on the desks tops. The bookcase and the desks are available with cable outlet.





INDEX ←





Collezione di tavoli bassi e consolle realizzati in un innovativo cristallo stratificato e incollato, che dà vita a straordinarie illusioni ottiche e meravigliosi effetti surreali. Gli oggetti osservati attraverso questo materiale, infatti, sembrano mutare la loro consistenza materica, variare la loro posizione, dimensione e quantità. La base, in specchio stratificato, riflette ed amplifica questi magici effetti.

Dimensioni:

DOL01	ø 47	H 50	DOL05	L 47	P 70	H 40
DOL02	ø 75	H 40	DOL06	L 70	P 70	H 40
DOL03	ø 90	H 35	DOL07	L 100	P 42	H 80
DOL04	L 47	P 47	H 50			



Collection of low tables and consoles made of an innovative laminated and glued glass, which gives life to extraordinary optical illusions and wonderful surreal effects. The objects observed through this material, in fact, seem to change their material consistency, vary their position, size and quantity. The base, in laminated mirror, reflects and amplifies these magical effects.

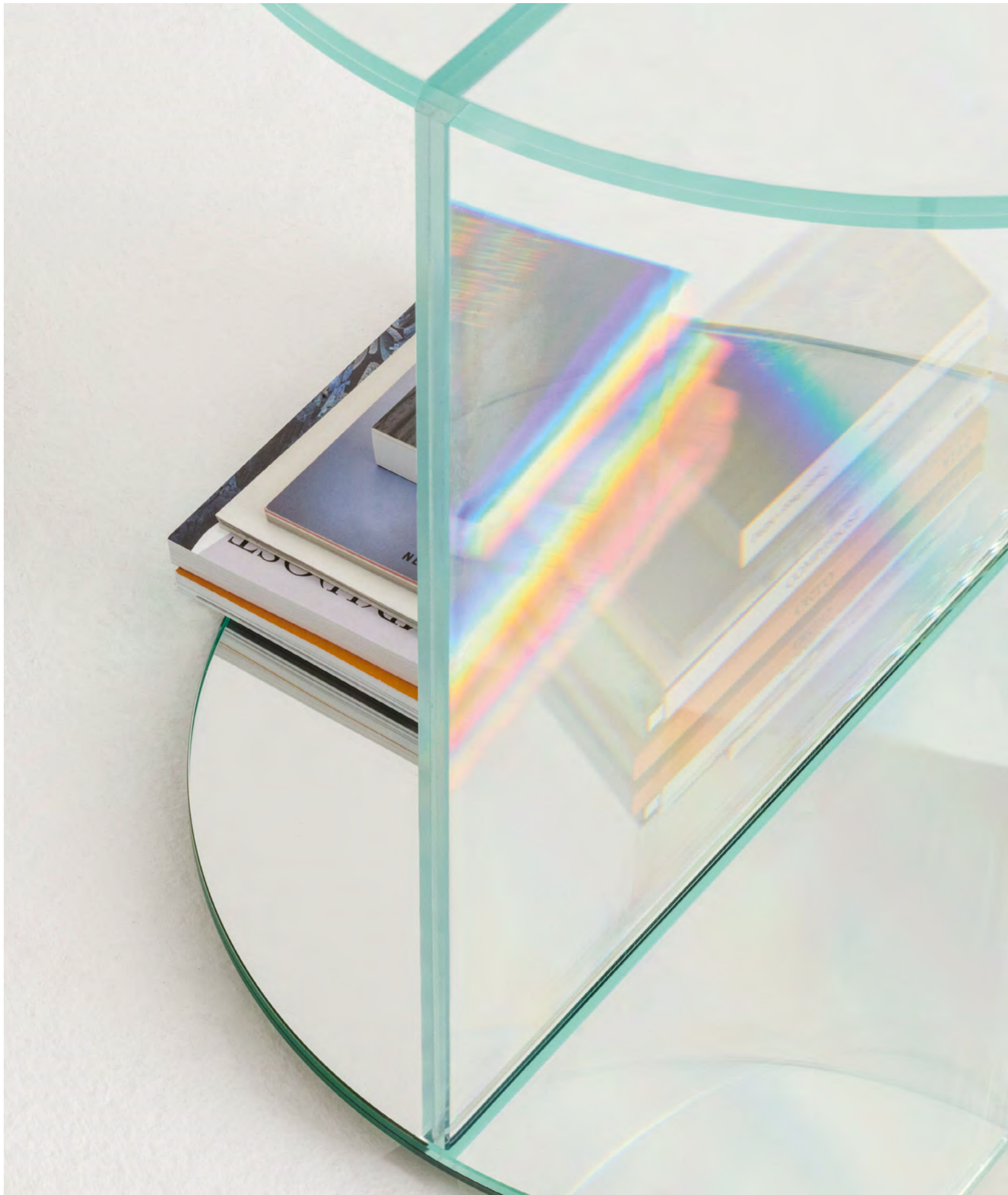





INDEX ←



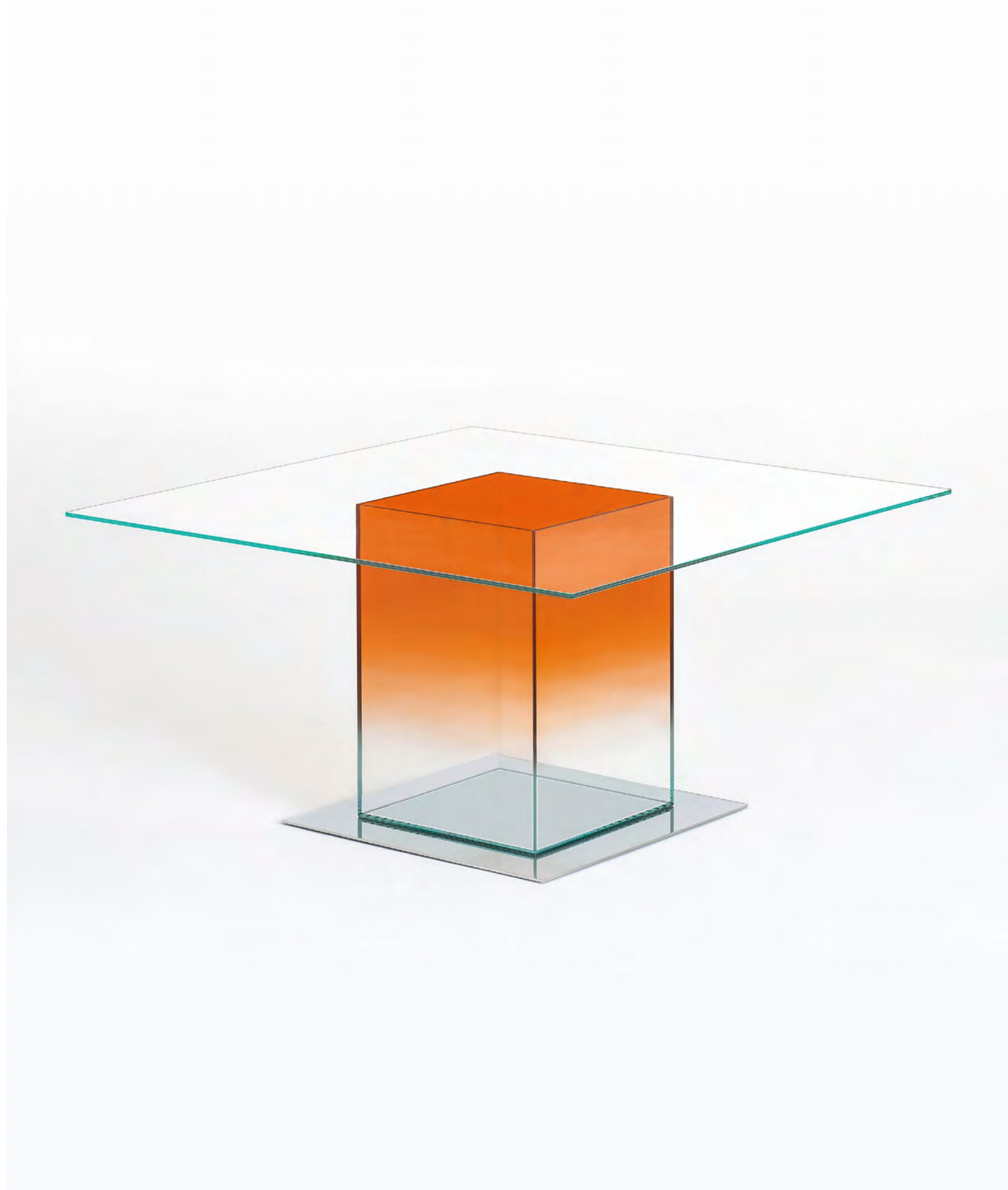

Tavoli alti di forma quadrata e rettangolare realizzati in cristallo extralight stratificato 6+6 mm. La base è composta da una piastra in acciaio inox di grosso spessore lucidato a specchio, sormontata da un volume in cristallo trasparente colorato, incollato a 45°, in cui il colore sfuma e digrada fino a dissolversi e svanire. E' possibile scegliere tra la versione con sfumatura che digrada verso il basso, oppure verso l'alto. E' inoltre disponibile con colore digradante grigio o arancione, oppure in una versione multicromatica, in cui i lati del parallelepipedo presentano differenti colori (giallo, arancio, rosa, rosso, verde), che si miscelano quando si sovrappongono nella trasparenza del vetro. Il top, in appoggio sulla base, è vincolato ad essa grazie da un ingegnoso e raffinato sistema ad incastro tra elementi di acciaio inox lucidato a specchio, incollati al cristallo.

Dimensioni:

DOA01 L 140 P 140 H 72
DOA02 L 150 P 150 H 72
DOA03 L 160 P 160 H 72

DOA04 L 230 P 85 H 72
DOA05 L 230 P 90 H 72
DOA06 L 250 P 90 H 72



Square and rectangular high tables in laminated 6+6 mm extralight glass. The base is made from a thick mirror-polished stainless steel plate, topped by a volume in colored transparent glass, bonded at 45 °, on which the color blends and fades until it dissolves and vanishes. It is possible to choose either a version with degrading shade downwards or upwards. A version is available with either grey or orange degrading shades, or with a multi-chromatic effect, with the sides of the parallelepipeds in different colors (yellow, orange, pink, red, green), which mix when overlapped with the transparency of the glass. The top, laid on the base, is joined to it thanks to an ingenious and refined interlocking system between mirror-polished stainless steel elements fixed to the glass.







Serie di tavolini/espositori, con la funzione di custodire e valorizzare gli oggetti in essi contenuti, realizzati in cristallo stratificato 3+3 mm, perfettamente incollato a 45°, disponibili in tre misure e nei dodici colori dei cristalli trasparenti colorati. Il coperchio appoggia su una base in acciaio inox supersilver, rifinita da un sottile bordo perimetrale, che impreziosisce e protegge il cristallo da eventuali urti. Questi parallelepipedi possono essere accostati per dar forma ad articolate composizioni volumetriche o vivere separatamente come singoli elementi.

Finiture: cristalli trasparenti colorati

Dimensioni: **DOB01** L 33 P 33 H 50
DOB02 L 33 P 66 H 35

DOB03 L 66 P 66 H 25



Series of coffee tables/display units, with the function of preserving and enhancing the objects contained therein, created in 3+3 mm thick laminated glass, perfectly bonded at 45°, available in three sizes and in the twelve colors of transparent colored glass. The top rests on a supersilver stainless steel base and is finished on the perimeter by a thin edge, which embellishes and protects the glass from any knocks. These parallelepipeds can be placed side by side to create articulated larger compositions or can be used separately as single elements.

Finishes: transparent coloured glass







INDEX ←





Serie di tavoli alti con piano in cristallo trasparente extralight 12 mm bisellato e temperato, sostenuto da due cavalletti realizzati in cristallo trasparente extralight 12 mm temperato e incollato.



Dimensioni:

DOC01 L 300 P 110 H 72
DOC02 L 250 P 110 H 72
DOC03 L 220 P 110 H 72

DOC04 L 250 P 125 H 72
DOC05 L 300 P 125 H 72



Series of high tables with top in chamfered and tempered 12 mm thick transparent extralight glass, supported by two trestles realized in tempered and glued 12 mm thick transparent extralight glass.





INDEX ←





Tavolino con base realizzata incollando tra di loro due lastre di cristallo temperato. È disponibile una versione realizzata completamente in cristallo fumé e una in cristallo trasparente extralight con un inserto di cristallo trasparente colorato blu, giallo o rosso. Il piano e la base sono assemblati tramite una piastra in acciaio lucido.

Dimensioni: DON Ø 48 H 54

Low table with base obtained by gluing one to each other two slabs of tempered glass. It is available a version completely in smoked glass and a version in transparent extralight glass with an insert of transparent blue, yellow or red coloured glass. The base and the top are assembled by means of a polished steel plate.



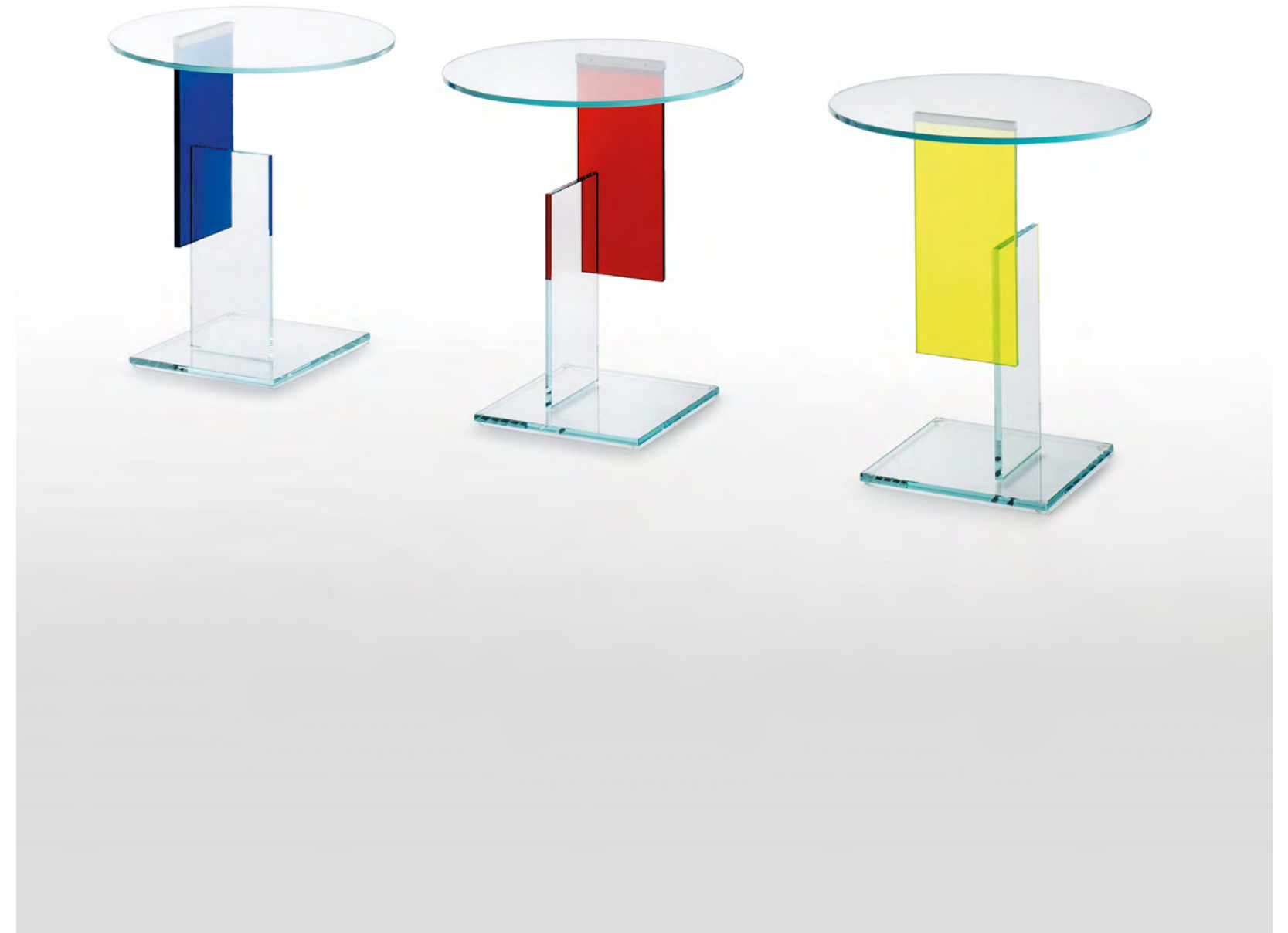
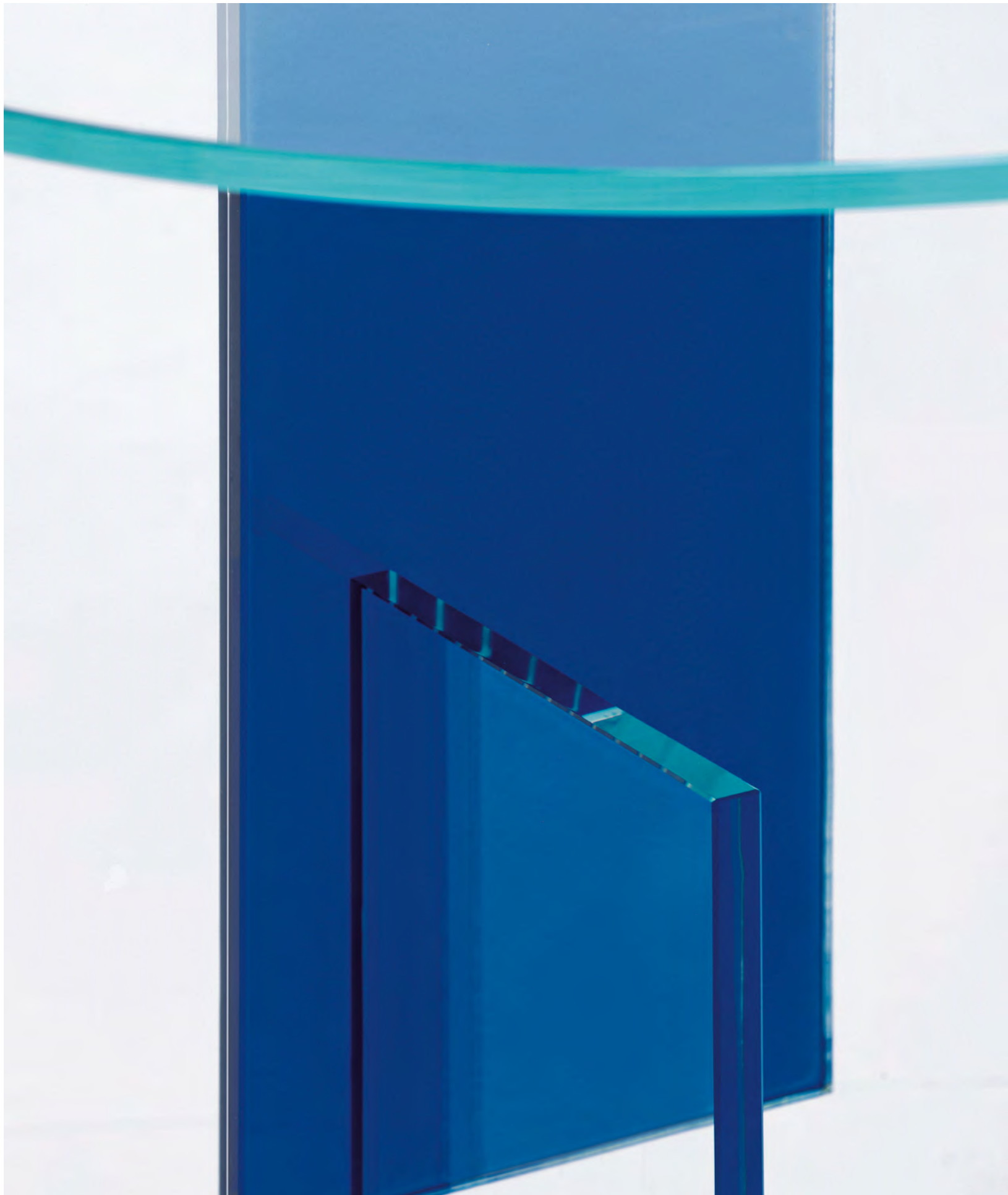



INDEX ←



Serie di cassetiere in cristallo di varie tipologie e misure con sistema di apertura a pressione. Le spalle e lo schienale, realizzate in cristallo trasparente extralight 12 mm incollato a 45°, sostengono cassetti in wengé rivestiti esternamente in cristallo temperato, laccato lucido in diversi colori. Il fondo dei cassetti è in cristallo nella medesima finitura dell'esterno.

Finiture: cristalli laccati lucidi



Dimensioni:

FLO02 L 63 P 45,5 H 50
FLO04 L 63 P 45,5 H 113
FLO05 L 122 P 45,5 H 90

FLO06 L 100 P 45,5 H 79
FLO07 L 45,5 P 45,5 H 50
FLO08 L 180 P 45,5 H 90



Series of glass chest of drawers of different types and sizes with a pressure opening system. The sides and the back, realized in 12 mm thick glued 45° transparent extralight glass, support drawers in wengé covered on the outside with tempered glass, glossy lacquered in different colours. The bottom of the drawers is in glass in the same finish as the outside.

Finishes: glossy lacquered glass





■ ← INDEX





Elegante e sobrio scrittoio ottenuto da un'unica lastra di cristallo trasparente extralight 15 mm curvato. Le armoniose curvature e la cura dei dettagli esplicitano e sottolineano le qualità intrinseche del materiale.

Dimensioni: FOL01 L 133 P 63 H 75

Elegant and simple desk made with a single sheet of transparent 15 mm thick extralight curved glass. The graceful curves and the attention to detail convey and emphasize the intrinsic qualities of the material.





■ ← INDEX





Tavoli bassi rotondi di grande preziosità e poesia, con base in cristallo di Murano colato, modellato e cesellato a mano secondo sapienti tecniche di lavorazione. Il piano, anch'esso in cristallo colato, è inserito in appoggio all'interno della base. Questi oggetti riproducono la poesia dell'acqua che sgorga da una fonte, con tutte le sue irregolari increspature e i vibranti scintillii.



Dimensioni:	FOU01 ø 38	H 42	FOU03 ø 65	H 21
	FOU02 ø 45	H 33	FOU04 ø 80	H 36



Precious and poetic round low tables with Murano poured glass bases, hand shaped and chiseled by finely honed production techniques. The top is also in poured glass and is inserted resting inside the base. These objects suggest the fluidity of water flowing from a spring with all its changing rivulets and glittering sparkle.







INDEX ←





Serie di tavolini rotondi con piano in cristallo temperato, laccato lucido o laccato opaco. Base in cristallo borosilicato trasparente, tornito e sagomato. Disponibili in due altezze e dimensioni.

Finiture: cristalli laccati lucidi / cristalli laccati opachi



Dimensioni: **TFU01** ø 42 H 39 **TFU03** ø 28 H 33



Series of round low tables with top in tempered glossy lacquered or lacquered opaque glass. Base in molded and shaped transparent borosilicate glass. Available in two heights and dimensions.

Finishes: glossy lacquered glass / opaque lacquered glass





INDEX ←





Tavolo basso dal raffinatissimo aspetto minimale con gambe in cristallo trasparente 24 mm termosaldate ad un piano in cristallo trasparente 12 mm temperato. Prodotto storico ed iconico del design internazionale, disegnato dal grande maestro Shiro Kuramata nel 1976.

Dimensioni: **KUT** L 120 P 120 H 38

Low table characterised by the very refined minimal aspect with feet in 24 mm thick transparent glass, thermo-welded to the top in 12 mm thick transparent tempered glass. Historical and iconic product of the international design, designed in 1976 by the great master Shiro Kuramata.







INDEX ←





Tavolini in cristallo trasparente extralight, disponibili in due misure differenti. Una complessa ed innovativa curvatura, caratterizzata da angoli ed inclinazioni molto ardite, conferisce ai tavolini grande dinamismo e plasticità. Questo virtuosismo tecnico dona al tavolino un aspetto di estrema leggerezza.



Dimensioni:

HAR01 L 58 P 58 H 33

HAR02 L 50 P 50 H 57



Low tables in transparent extralight glass, available in two different sizes. A complex and innovative curvature, characterized by particularly daring angles and gradients, confers great dynamism and plasticity to the low tables. This technical virtuosity gives the low table an extremely light appearance.





INDEX ←





Serie di tavoli alti e bassi di forma rotonda. Il piano, in cristallo 12 mm temperato, è sostenuto da una base composta da un cilindro cavo di cristallo borosilicato e da un piede in cristallo 12 mm temperato, fornito di zavorra. Disponibili con piano e piede in cristallo laccato lucido e opaco o, ad eccezione di Hub Basso, con piano trasparente extralight e piede in specchio extralight. Il piano è smontabile e fissato alla base tramite una coppia di anelli d'alluminio anodizzato inox.

Finiture: cristalli laccati lucidi / cristalli laccati opachi / Cristallo trasparente extralight (top) + specchio extralight (piede)

Dimensioni:	HUB02	ø 140	H 72	bistrot HUB07	ø 80	H 72
	HUB03	ø 150	H 72	bistrot HUB08	ø 90	H 72
	HUB04	ø 160	H 72	bistrot HUB09	ø 100	H 72
	HUB06	ø 50	H 35	HUB10	ø 170	H 72
	HUB11	ø 50	H 44	HUB12	ø 180	H 72

Series of round high and low tables. The top is tempered glass 12 mm thick is supported by a base composed of a hollow cylinder in borosilicate glass and a foot in 12 mm thick glass providing ballast. The top and the foot are available in glossy or opaque lacquered glass or, except for the low version, with transparent extralight top and foot in extralight mirror. The top can be disassembled and fixed to the base by means of rings in stainless steel anodized aluminum.

Finishes: glossy lacquered glass / opaque lacquered glass / Transparent extralight glass (top) + extralight mirror (foot)







INDEX ←





Tavoli alti con piano in cristallo extralight 15 mm temperato, con il bordo caratterizzato da preziose e brillanti sfaccettature di varie larghezze e inclinazioni. Il piano è sostenuto da una base composta da un cilindro cavo di cristallo borosilicato e da un piede in specchio extralight 12 mm temperato. Il piano è smontabile e fissato alla base tramite una coppia di anelli d'alluminio anodizzato inox.

Dimensioni:

CUT01

ø 153 H 72

CUT02

ø 180 H 72

High tables with top in 15 mm thick extralight tempered glass, with edge characterized by precious and brilliant beveling of various widths and angles. The top is supported by a base composed of a hollow cylinder in borosilicate glass and a foot in extralight tempered mirror 12 mm thick. The top can be disassembled and fixed to the base thanks to stainless steel anodized aluminum rings.







INDEX ←





Collezione di tavoli bassi-panche, realizzati incollando insieme tre lastre di cristallo fumè in modo tale da assumere l'aspetto di una putrella. Il pianoseduta e la base sono in cristallo temperato 12 mm, mentre il supporto verticale è in cristallo stratificato. Nonostante la giunzione dei cristalli sia molto esigua e lineare, l'impiego di incollaggi strutturali ad alta resistenza permette di utilizzare questi elementi come sedute. La collezione è completata da cuscini sfoderabili in tessuto di colore nero.

Dimensioni:

IBE02 L 60 P 60 H 29
IBE03 L 200 P 60 H 29
IBE04 L 140 P 60 H 29

IBE06 L 60 P 60
cuscino / cushion
IBE07 L 140 P 60
cuscino / cushion



Collections of low tables-benches, obtained by gluing together three slabs of smoked glass so that they look like a joist. The top-seat and the base are in 12 mm thick tempered glass, whereas the vertical support is in laminated glass. Although the glass junction is very little and linear, the adoption of high resistant structural gluing enables the use of these elements as seats. The collection is completed by removable cushions in a black colour fabric.





INDEX ←





Serie di tavoli bassi a forma di parallelepipedo con piano con finitura a specchio e fianchi a specchio sfumato digradante. Realizzati in cristallo extralight incollato a 45°.

Dimensioni:

ILL01 L 39 P 39 H 39
ILL02 L 39 P 39 H 60
ILL03 L 39 P 39 H 80

ILL04 L 110 P 110 H 33
ILL05 L 70 P 70 H 33
ILL06 L 160 P 70 H 33

Series of parallelepiped shaped low tables with mirroring top and degrading shading mirroring sides. Realized in extralight glass, glued at 45°.



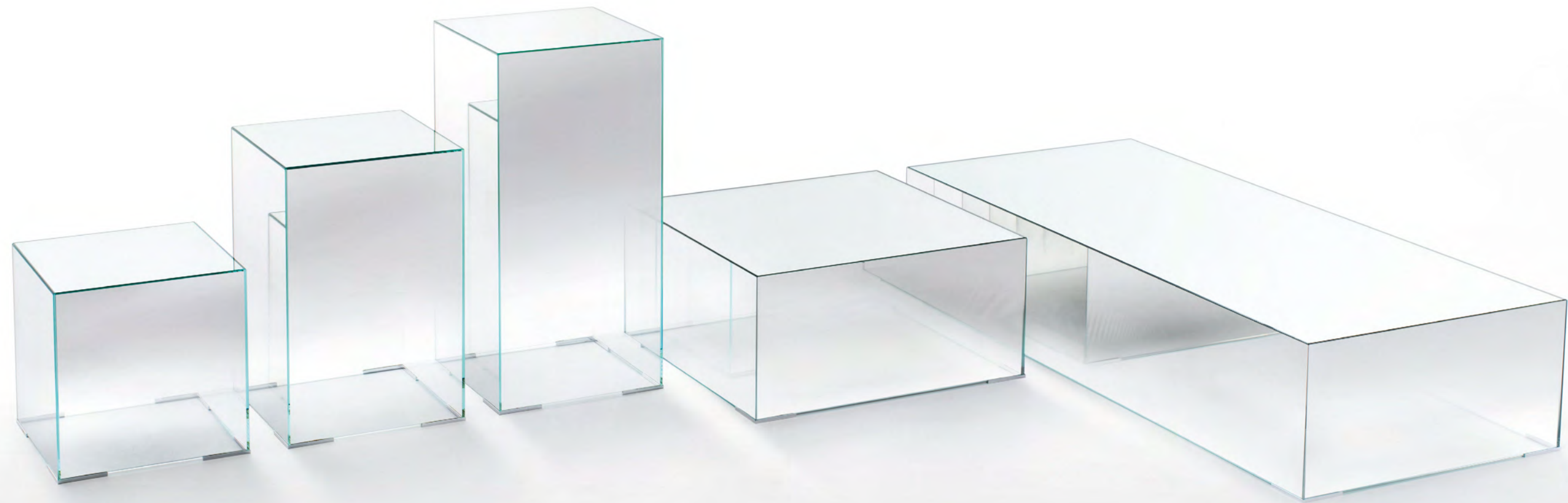



INDEX ←





Tavoli bassi con ruote a forma di parallelepipedo e di aspetto monolitico, realizzati incollando lastre di specchio bisellato a 45°.



Dimensioni:

TMA01 L 201 P 67 H 19

TMA02 L 72 P 72 H 19

TMA03 L 133 P 72 H 19

TMA04 L 103 P 103 H 19



Low tables with wheels in a parallelepiped form and with monolithic figure, obtained by gluing 45° chamfered mirror slabs.







Collezione di arredi composta da mensole, console e tavolo basso, completamente realizzata in uno speciale cristallo verde acidato bifacciale da 10 mm temperato, o in cristallo extralight acidato bifacciale da 10 mm temperato. Ogni articolo è una composizione di lastre di cristallo sovrapposte che, giuntate tra di loro in purezza grazie all'incollaggio UV, danno forma a raffinati arredi scultorei dall'assoluto rigore formale. Le mensole possono essere appese capovolte.

**Dimensioni:**

KAZ07 L 124 P 33 H 92
console

KAZ08 L 109 P 108 H 40
tavolino



Collection of furniture consisting of shelves, console and low table, completely made of a special 10 mm tempered double-sided green acid-etched glass, or, in 10 mm tempered double-sided acid-etched extralight glass. Each item is a composition of interlocked and overlapping glass sheets which, through a special UV bonding method, give shape to pure and refined sculptural furnishing elements characterized by a rigorous form. The shelves can be hung upside down.

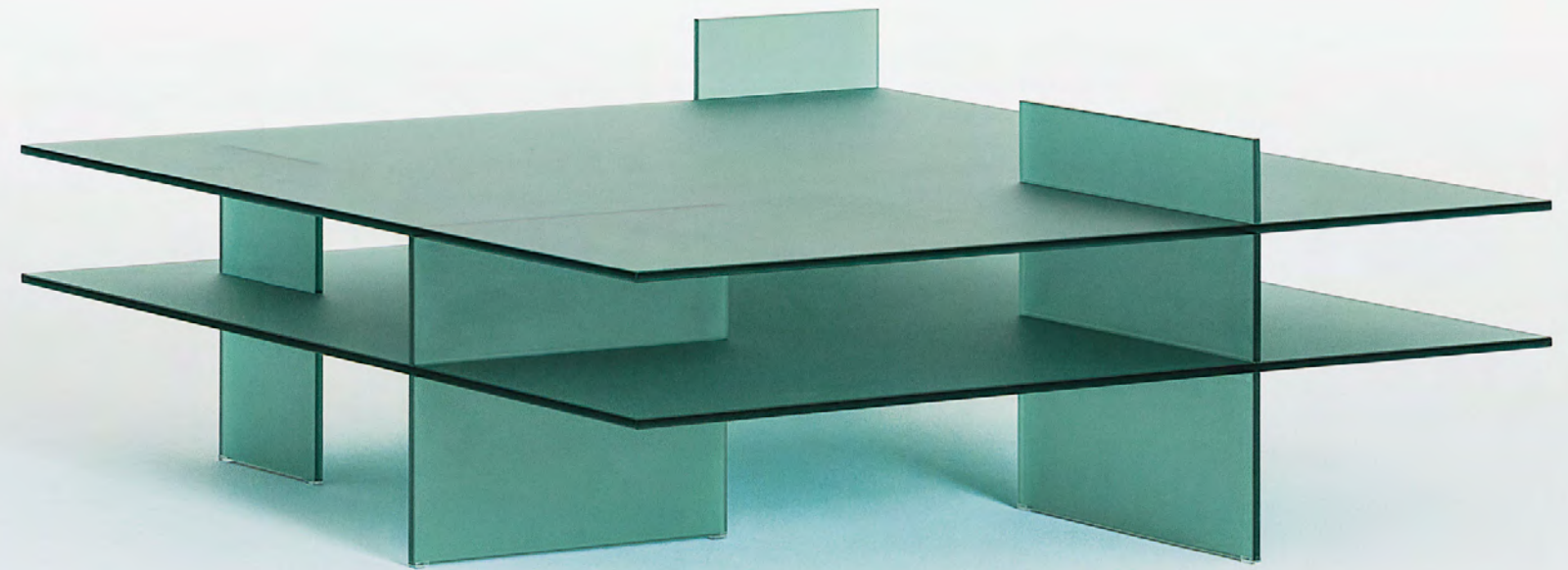
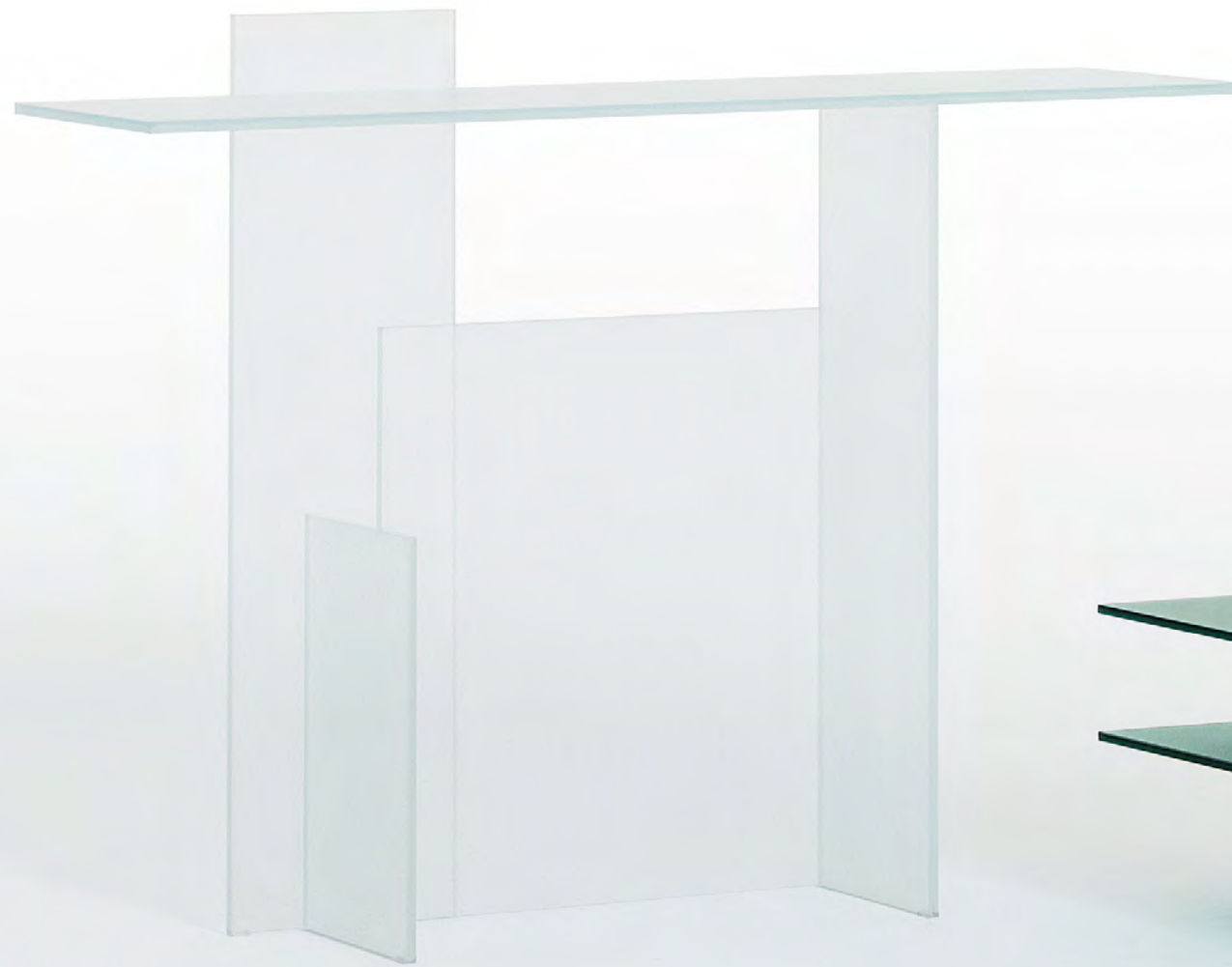





INDEX ←





Tavolo basso con forma di ovaloide, realizzato in cristallo trasparente extralight 15 mm. Il piano e le gambe presentano delle sfaccettature ottenute grazie a speciali bisellature del cristallo.

Dimensioni:

KOT03 L 141 P 98 H 30
con 3 gambe/with 3 legs

Low table with ovaloide shape, realized in 15 mm thick transparent extralight glass. The top and the feet have facetings obtained by means of special chamferings of the glass.







INDEX ←





Tavoli alti di forma rotonda con disco girevole servi vivande Ø70 cm dal movimento fluido e silenzioso, perfettamente incassato ed allineato al centro del piano. L'anello esterno del piano e il piede del tavolo sono in cristallo temperato 12 mm, laccato lucido o opaco, mentre il disco girevole è disponibile in cristallo temperato nelle medesime finiture, oppure in specchio stratificato colorato (nelle tonalità dei cristalli trasparenti colorati). Il piano, smontabile, è sostenuto da un cilindro cavo di cristallo borosilicato, fissato ad una zavorra posizionata sotto al piede di cristallo laccato.

Finiture: cristalli laccati lucidi / cristalli laccati opachi / cristalli trasparenti colorati (con specchio) - solo per disco girevole

Dimensioni:	LAZ01 ø 160	H 74	LAZ03 ø 180	H 74
	LAZ02 ø 170	H 74		

Round-shaped high tables with rotating Ø70 cm disc for serving food with a smooth and silent movement, perfectly recessed and flush in the center of the tabletop. The outer ring of the top and the foot of the table are in 12 mm tempered glass, glossy or opaque lacquered, while the rotating disc is available in tempered glass in the same finishes, or in colored laminated mirror (same colors of transparent colored glass). The removable top is supported by a borosilicate glass cylinder, fixed to a ballast positioned under the lacquered glass foot.

Finishes: glossy lacquered glass / matt lacquered glass / transparent colored glass (mirror) - only for the rotating disc







INDEX ←





Tavoli bassi di forma rotonda con struttura in tubo metallico verniciato nei colori blu notte o rame in una speciale finitura metallizzata opaca. Il piano, in vetro stratificato, è una tavolozza di colori su un fondo a specchio, che sfumano e si fondono tra loro come gas o fluidi, dissimulando lo stato solido della materia. Il fondo a specchio conferisce una particolare energia e luminosità a questa nuance di colori.



Dimensioni: **LAS01** ø 79 H 40 **LAS03** ø 114 H 30
 LAS02 ø 94 H 35



Low round tables with tubular metal structure painted midnight blue or copper colour in a special metallic opaque finish. The top, in laminated glass, is a palette of colours on a mirrored background, blending and mixing with one another like gas or fluids, disguising the solid state of the material. The mirrored background lends a particular energy and brightness to these colour tones.





INDEX ←



Serie di tavoli alti, bassi e consolle in cristallo trasparente extralight temperato, con una decorazione venata ed organica, che riprende le colorazioni e le trame del marmo. Grazie ad un sorprendente effetto di cambio immagine, le venature risultano essere dinamiche e variabili, allo spostarsi del punto di osservazione. Disponibili in quattro diverse colorazioni: verde, rosa-beige, whisky e grigio antracite. Il decoro è racchiuso da una cornice in colore coordinato, verniciata sul perimetro dei vetri.

Dimensioni:

ovale	LIQ01	L 60	P 50	H 51	LIQ08	L 180	P 120	H 73
ovale	LIQ02	L 90	P 60	H 46	LIQ09	L 120	P 90	H 73
ovale	LIQ03	L 120	P 90	H 41	consolle LIQ10	L 120	P 42	H 85
ovale	LIQ04	L 180	P 115	H 73	LIQ11	L 120	P 120	H 36
	LIQ05	ø 120		H 73	LIQ12	ø 120		H 36
	LIQ06	L 120	P 120	H 73	LIQ13	L 120	P 90	H 36
	LIQ07	L 180	P 100	H 73				

High and low tables and console in tempered extralight glass with a veined and organic decoration which takes on the colour and veins of marble. The surprising image changing effect, makes the veining look dynamic and variable depending on the viewing point. Available in four different colors: green, pink-beige, whisky and anthracite-grey. The decoration is enclosed by a coordinated colour frame painted on the glass perimeter.

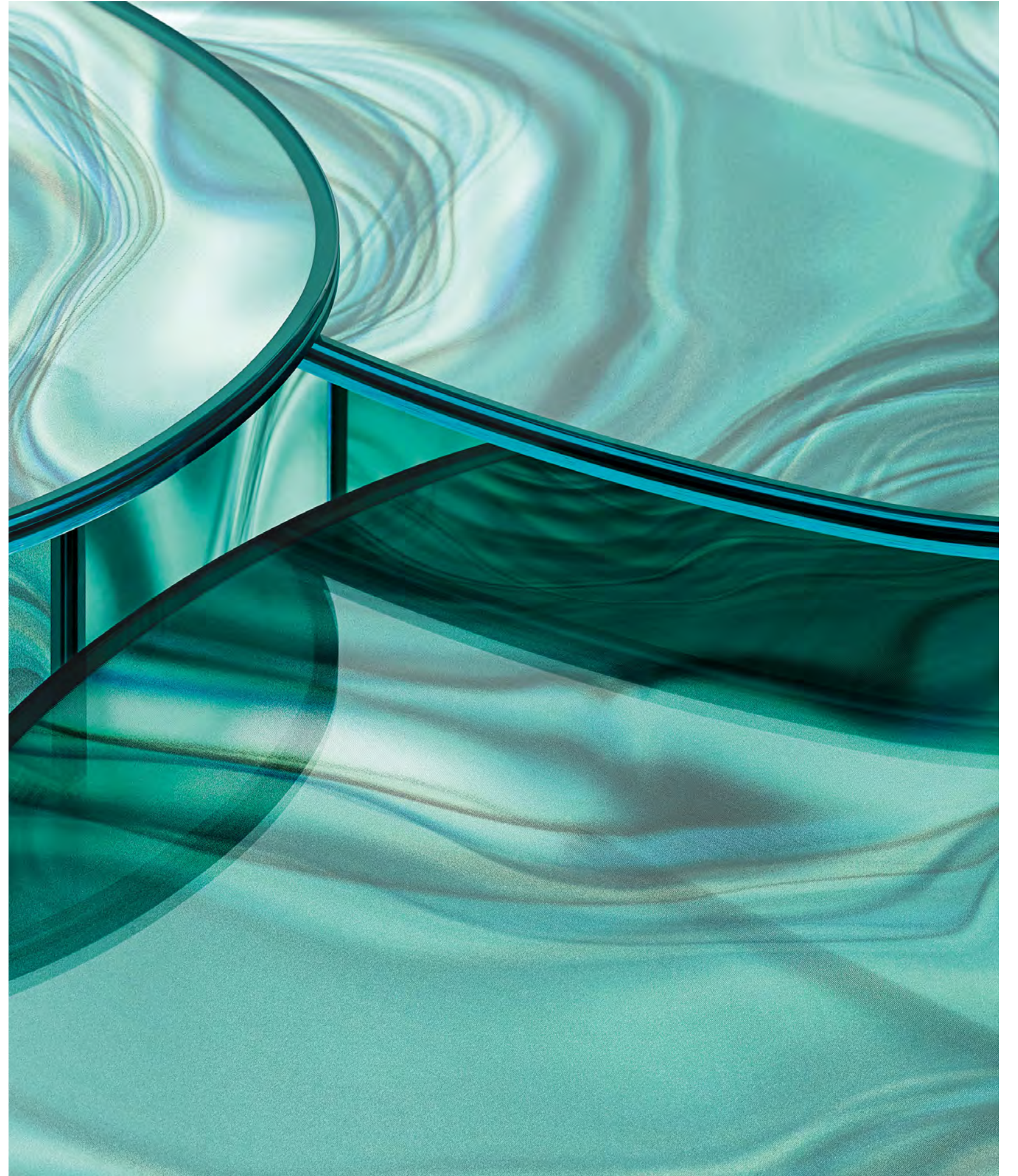







INDEX ←





Serie di tavoli alti rettangolari disponibili con un piano in cristallo 12 mm temperato trasparente extralight o in cristallo stratificato 6+6 mm in speciali colori trasparenti: rosa chiaro, grigio chiaro o giallo chiaro. La base è composta da due cavalletti d'acciaio inox lucidati a specchio, uniti da una trave in cristallo extralight stratificato 19+19 mm, disponibile in finitura trasparente neutra o negli speciali colori trasparenti colorati del piano.

Finiture: cristallo trasparente extralight / cristalli trasparenti colorati

Dimensioni:

MAC01 L 200 P 80 H 72
MAC02 L 200 P 90 H 72
MAC03 L 220 P 80 H 72

MAC04 L 220 P 90 H 72
MAC05 L 250 P 90 H 72



Series of rectangular dining tables available with the top in 12 mm tempered transparent extralight glass or in laminated 6+6 mm glass in unique transparent colours: light pink, light grey or light yellow. The base is composed of two trestles in mirror-polished stainless steel. These are joined by a beam in 19+19 mm laminated extralight glass, available in a neutral transparent finish or in the unique transparent coloured finishes of the top.

Finishes: extralight transparent glass / transparent coloured glass





Serie di tavoli alti, bassi e console con piano in cristallo trasparente extralight 19 mm temperato. Le gambe cilindriche con Ø 50 mm, sono in alluminio spazzolato anodizzato inox o dark brown e sono fissate a piastre incollate al piano.

Dimensioni:

MET01 L 180 P 80 H 72 <i>con 4 gambe/with 4 legs</i>	MET24 Ø 140 H 72 <i>con 3 gambe/with 3 legs</i>
MET02 L 180 P 90 H 72 <i>con 4 gambe/with 4 legs</i>	MET25 Ø 150 H 72 <i>con 3 gambe/with 3 legs</i>
MET03 L 200 P 80 H 72 <i>con 4 gambe/with 4 legs</i>	MET26 Ø 160 H 72 <i>con 3 gambe/with 3 legs</i>
MET04 L 200 P 90 H 72 <i>con 4 gambe/with 4 legs</i>	MET27 Ø 170 H 72 <i>con 3 gambe/with 3 legs</i>
MET05 L 220 P 80 H 72 <i>con 4 gambe/with 4 legs</i>	MET28 L 120 P 120 H 72 <i>con 4 gambe/with 4 legs</i>
MET06 L 220 P 90 H 72 <i>con 4 gambe/with 4 legs</i>	MET29 L 130 P 130 H 72 <i>con 4 gambe/with 4 legs</i>
MET07 L 250 P 80 H 72 <i>con 4 gambe/with 4 legs</i>	MET30 L 140 P 140 H 72 <i>con 4 gambe/with 4 legs</i>
MET08 L 250 P 90 H 72 <i>con 4 gambe/with 4 legs</i>	MET31 L 150 P 150 H 72 <i>con 4 gambe/with 4 legs</i>
MET09 L 280 P 90 H 72 <i>con 6 gambe/with 6 legs</i>	MET32 L 160 P 160 H 72 <i>con 4 gambe/with 4 legs</i>
MET10 L 280 P 100 H 72 <i>con 6 gambe/with 6 legs</i>	MET33 L 130 P 60 H 30 <i>con 4 gambe/with 4 legs</i>
MET11 L 300 P 90 H 72 <i>con 6 gambe/with 6 legs</i>	MET34 L 150 P 60 H 30 <i>con 4 gambe/with 4 legs</i>
MET12 L 300 P 100 H 72 <i>con 6 gambe/with 6 legs</i>	MET35 L 180 P 60 H 30 <i>con 4 gambe/with 4 legs</i>
MET13 L 320 P 90 H 72 <i>con 6 gambe/with 6 legs</i>	MET36 L 200 P 60 H 30 <i>con 4 gambe/with 4 legs</i>
MET14 L 320 P 100 H 72 <i>con 6 gambe/with 6 legs</i>	MET37 L 110 P 110 H 30 <i>con 4 gambe/with 4 legs</i>
MET15 L 350 P 90 H 72 <i>con 6 gambe/with 6 legs</i>	MET38 L 120 P 120 H 30 <i>con 4 gambe/with 4 legs</i>
MET16 L 350 P 100 H 72 <i>con 6 gambe/with 6 legs</i>	MET39 L 130 P 130 H 30 <i>con 4 gambe/with 4 legs</i>
MET17 L 150 P 35 H 72 <i>con 4 gambe/with 4 legs</i>	MET40 L 140 P 140 H 30 <i>con 4 gambe/with 4 legs</i>
MET18 L 180 P 35 H 72 <i>con 4 gambe/with 4 legs</i>	MET41 L 150 P 150 H 30 <i>con 4 gambe/with 4 legs</i>
MET19 L 200 P 35 H 72 <i>con 4 gambe/with 4 legs</i>	MET42 Ø 110 H 30 <i>con 3 gambe/with 3 legs</i>
MET20 L 220 P 35 H 72 <i>con 4 gambe/with 4 legs</i>	MET43 Ø 120 H 30 <i>con 3 gambe/with 3 legs</i>
MET21 L 250 P 35 H 72 <i>con 4 gambe/with 4 legs</i>	MET44 Ø 130 H 30 <i>con 3 gambe/with 3 legs</i>
MET22 Ø 120 H 72 <i>con 3 gambe/with 3 legs</i>	MET45 Ø 140 H 30 <i>con 3 gambe/with 3 legs</i>
MET23 Ø 130 H 72 <i>con 3 gambe/with 3 legs</i>	MET46 Ø 150 H 30 <i>con 3 gambe/with 3 legs</i>

Series of high, low tables and consoles with top in 19 mm thick transparent extralight tempered glass. The cylindrical feet diameter Ø 50 mm are in brushed aluminium anodized inox or dark brown and are fixed to plates glued to the top.

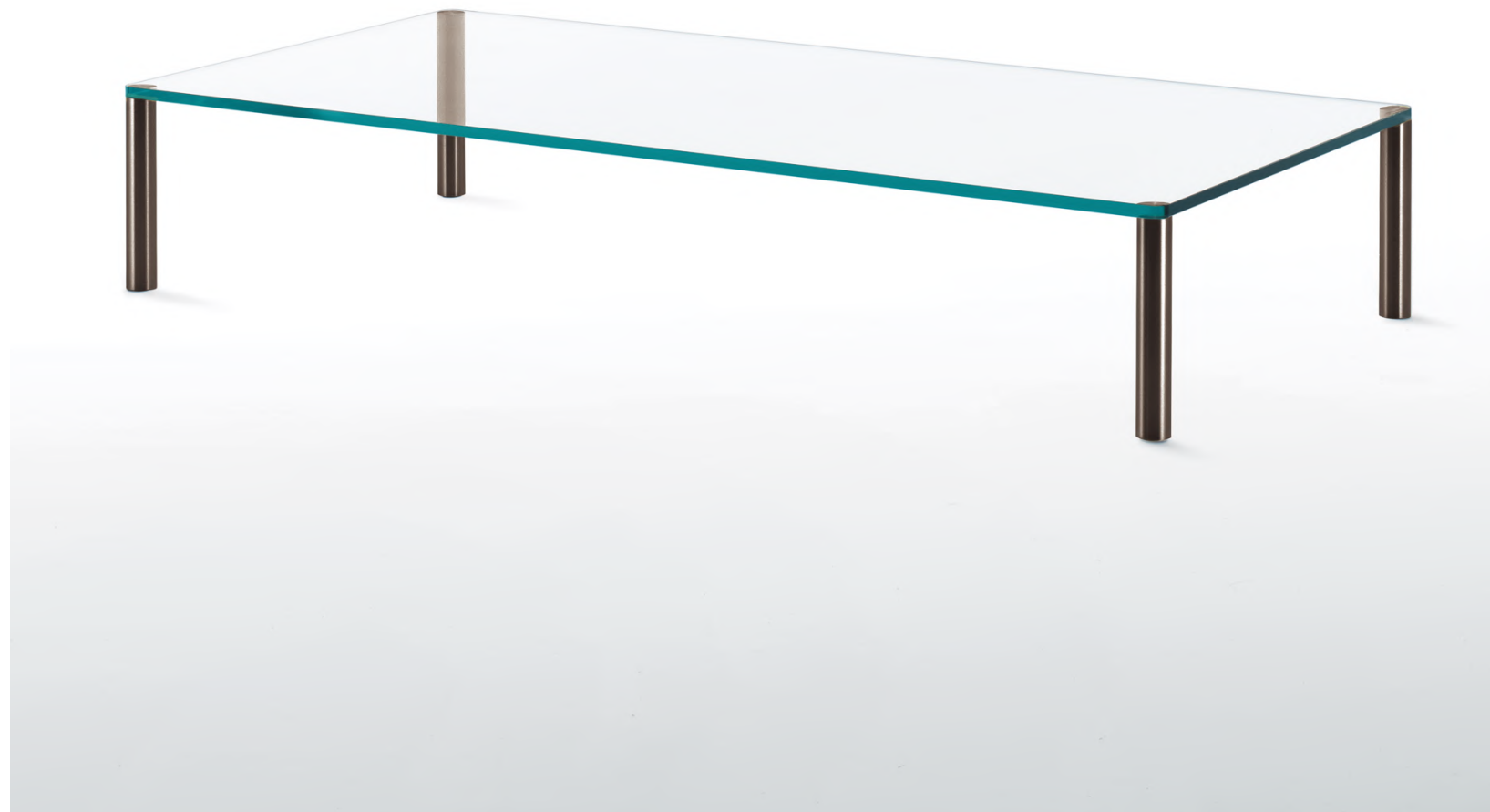



INDEX ←





Collezione di tavoli bassi e consolle disponibili in varie misure, la cui base è realizzata incollando a 45° lastre di specchio stratificato bifacciale, tagliato a getto d'acqua. Nei tavoli bassi il piano a specchio rimane ribassato all'interno della base, in modo da essere contenuto da un'alzatina. Nelle consolle, invece, il piano rimane in appoggio sulla base.

Dimensioni:

MIR03 L 150 P 38 H 85
MIR04 L 110 P 38 H 85
MIR05 L 110 P 110 H 33

MIR06 L 70 P 70 H 33
MIR07 L 130 P 70 H 33
MIR08 L 40 P 40 H 45

Collection of low tables and consoles available in different sizes, which base is obtained by gluing 45° water jet cut laminated double faced mirror slabs. In the low tables the mirror top rests lower down within the base frame, so as to be contained by an upstand profile. In the consoles the top instead is resting on the base frame.







■ ← INDEX





Nacre è un tavolo basso dall'aspetto fluido che trae ispirazione dalla forma organica di una conchiglia d'ostrica. La base è costituita da una vasca ovale in cristallo trasparente extralight con fondo a specchio, ottenuta deformando con un complesso processo termico una lastra piana da 12 mm e rifilandola perimetralmente. Il top, in appoggio sulla vasca, è in vetro stratificato 6+6 mm con finitura a specchio extralight che sfuma in maniera circolare, definendo un'area trasparente di forma rotonda. Il top è disponibile anche con un foro, in corrispondenza dell'area trasparente, attraverso il quale si ha accesso all'interno della vasca, per poterla utilizzare come fioriera, terrario o contenitore-espositore di oggetti.

**Dimensioni:**

NAC01 L 128 P 92 H 37
senza foro/without hole

NAC02 L 128 P 92 H 37
con foro/with hole



Nacre is a low table with a fluid aspect inspired by the organic form of an oyster shell. The base, made up of an oval basin in transparent extralight glass with mirrored bottom, is created by moulding a flat slab of 12 mm. glass through a complex heat treatment and trimming the perimeter to shape. The top, placed on the basin, is in laminated glass 6+6 mm in extralight mirror finish which fades in a circular way, emphasizing the transparent round area. The top is also available with an opening next to the transparent area, through which you can access the inside of the basin, and use it as flower box, terrarium (planter) or storage/display unit.





INDEX ←



Tavoli alti e bassi realizzati interamente in vetro di Murano, dalla forza materica e plasticità straordinarie. I piani di forma quadrata sono in vetro colato di grosso spessore, mentre le gambe cilindriche in vetro soffiato. Disponibili nelle colorazioni ambra o cristallo trasparente. Nei tavoli bassi le gambe sono saldate direttamente al piano, mentre nei tavoli alti sono fissate allo stesso grazie a piastre in acciaio inox avvitate tra loro.

Finiture: cristallo trasparente / cristallo ambra

Dimensioni:

NES03 L 42 P 42 H 34
NES04 L 42 P 42 H 42

NES05 L 80 P 80 H 38
NES06 L 80 P 80 H 72

High and low tables made entirely from Murano glass, characterized by extraordinary strength and plasticity of the material. The square tops are made with extremely thick poured glass, while the cylindrical legs are in blown glass. Available in amber or transparent glass. The low table legs are welded directly to the top, whilst the high table legs are attached to the top with stainless steel plates screwed together.

Finishes: clear crystal / amber crystal







INDEX





Tavolo basso che consiste in una lastra di cristallo extrachiaro 12 mm molato filo lucido, curvato a 180°, temperato chimicamente. Sulla base è posizionato un elemento a "L" in specchio bifacciale, che funge da appoggio per libri ed enfatizza la curvatura del vetro.



Dimensioni: OLI02 L 57 P 35 H 51



Low table comprised of a 12 mm extra-clear glass plate with polished shiny edge, curved 180° and chemically tempered. An "L" shaped element in double-sided mirror, positioned on the base, acts as a support for books and emphasizes the curved glass.

Consolle dalle raffinate ed innovative soluzioni tecniche ed estetico-decorative. Sulla superficie inferiore del top, in cristallo extrachiario stratificato 10+10 mm, è incollato a UV un cristallo extrachiario curvo con funzione porta oggetti, mentre sulla superficie superiore è fissato un cassetto con apertura push-pull, rivestito in cristallo laccato lucido. La piantana verticale è in cristallo temperato stratificato 12+12 mm con finitura trasparente extralight o nella gamma dei Cristalli Trasparenti Colorati. Top e piantana sono assemblati e smontabili tramite una coppia di piastre metalliche lucidate a specchio. La base, fornita di piedini regolabili e fissata alla piantana verticale in maniera removibile, è rivestita in specchio 10 mm. Il cassetto può essere montato con apertura sul fronte o sul retro.

Finiture:

- Cristalli Laccati Lucidi (per cassetto)
- Cristallo trasparente extralight + Cristalli Trasparenti Colorati (per piantana)

Dimensioni: OLI03 L 155 P 37,5 H 92

Console featuring refined and innovative technical and aesthetic-decorative solutions. On the lower surface of the top, in 10+10 mm laminated extra-clear glass top, a curved extra-clear glass with storage function is UV bonded, while on the upper surface a drawer with push-pull opening is attached, covered in glossy lacquered glass. The vertical stand is made of 12+12 mm laminated tempered glass, in extra-clear glass or in Coloured Transparent glass. The top and stand are assembled and disassembled by using a couple of mirror-polished metal plates. The base, equipped with adjustable small feet and removably attached to the vertical stand, is covered in 10 mm mirror. The drawer can be mounted with an opening from the front or rear.

Finishes:

- Glossy lacquered glass (for the drawer)
- Extra-clear transparent glass + Coloured transparent glass (for the vertical stand)



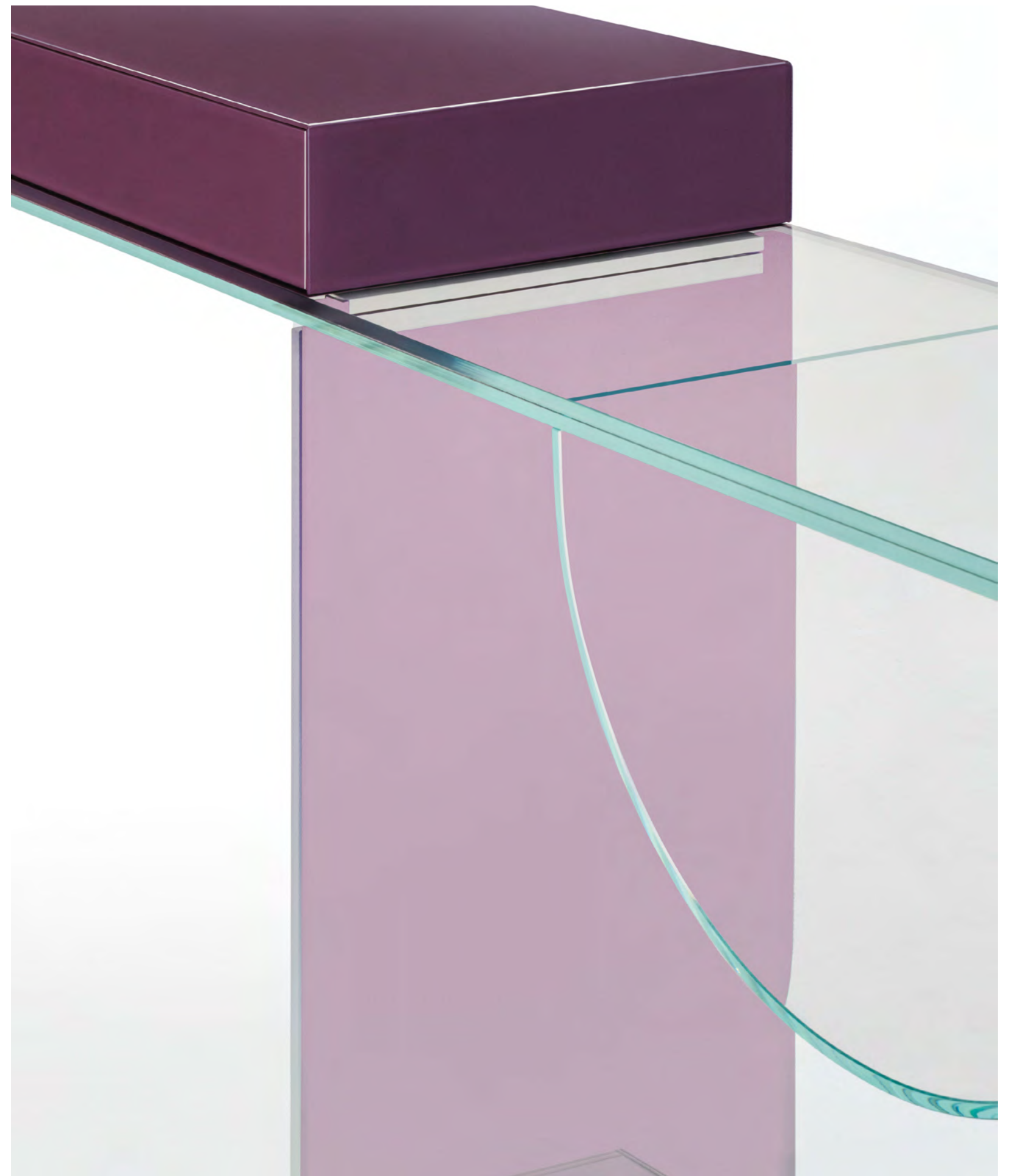



← INDEX





Tavolo in cristallo trasparente extralight dall'estrema leggerezza e pulizia formale. La base molto esile, nonostante un'apparenza di fragilità e delicatezza, è solida e resistente grazie ad uno speciale trattamento del cristallo. Il piano, in cristallo temperato, va in appoggio sulla base.



Dimensioni:

OSC01 L 190 P 90 H 74

OSC02 L 140 P 140 H 74

OSC03 L 190 P 190 H 74

OSC05 L 220 P 90 H 74



Table in transparent extralight glass characterised by extreme lightness and formal cleanliness. The very slender base, despite of an apparent fragility and fineness, is solid and resistant thanks to a special treatment of the glass. The top, in tempered glass, rests on the base.

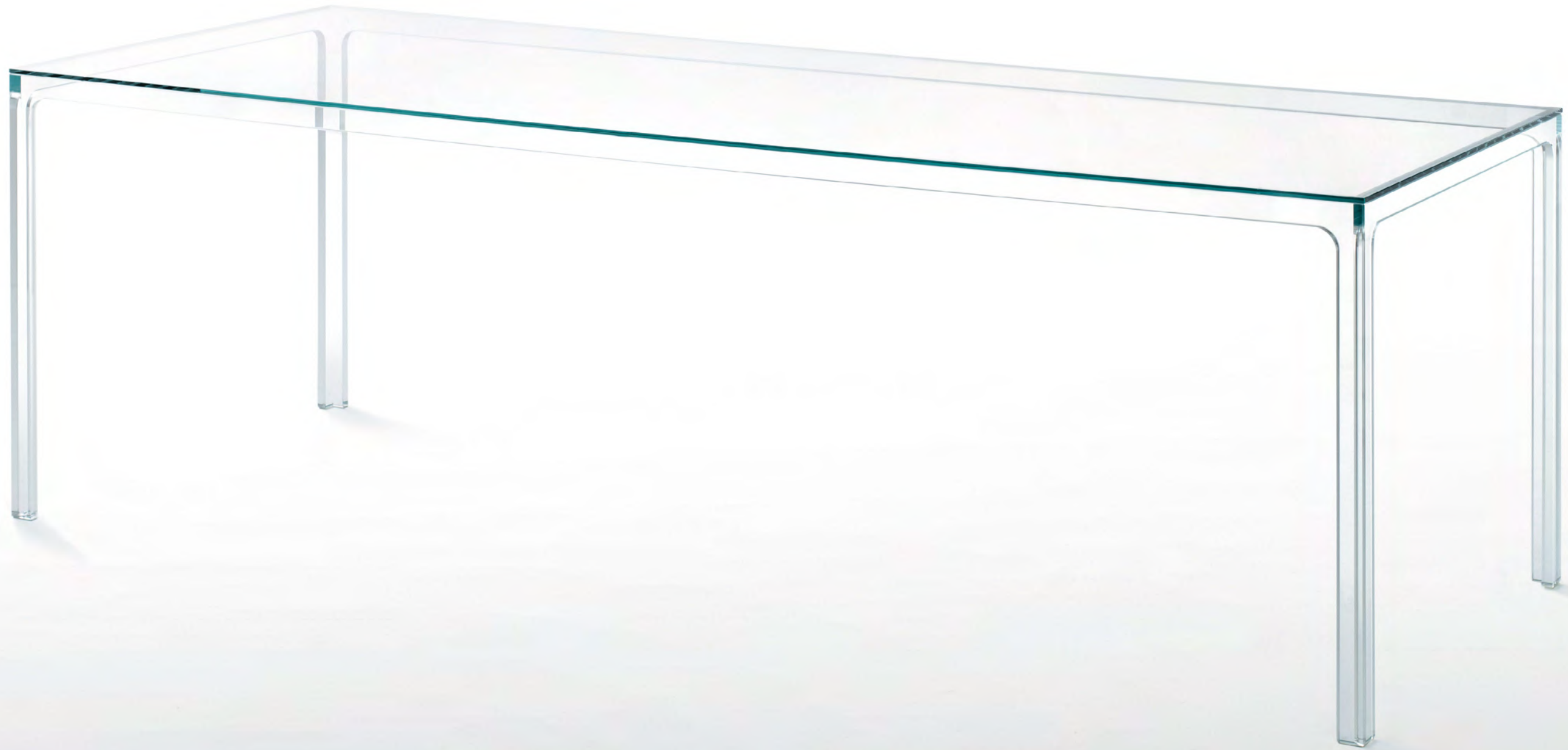



INDEX ←





Serie di tavoli alti e bassi di forma quadrata, rettangolare e rotonda. Il piano, con spessore di 15 mm è disponibile in cristallo trasparente, trasparente extralight, laccato lucido temperato. Le gambe cilindriche sono in cristallo borosilicato trasparente.

Finiture: cristallo trasparente / cristallo trasparente extralight / cristalli laccati lucidi

Dimensioni:

PIP01	L 180	P 90	H 72	PIP21	∅ 160	H 72	
PIP02	L 200	P 90	H 72	<i>con 3 gambe/with 3 legs</i>			
PIP03	L 200	P 100	H 72	PIP22	∅ 170	H 72	
PIP04	L 210	P 90	H 72	<i>con 3 gambe/with 3 legs</i>			
PIP05	L 210	P 100	H 72	PIP11	L 90	P 90	H 30
PIP06	L 220	P 90	H 72	PIP12	L 100	P 100	H 30
PIP07	L 220	P 100	H 72	PIP13	L 110	P 110	H 30
PIP08	L 130	P 130	H 72	PIP14	L 120	P 120	H 30
PIP09	L 140	P 140	H 72	PIP15	L 130	P 130	H 30
PIP10	L 150	P 150	H 72	PIP16	L 130	P 70	H 30
PIP19	∅ 140		H 72	PIP17	L 140	P 80	H 30
<i>con 3 gambe/with 3 legs</i>				PIP18	L 160	P 80	H 30
PIP20	∅ 150		H 72	PIP23	∅ 120		H 30
<i>con 3 gambe/with 3 legs</i>				PIP24	∅ 130		H 30

Series of high and low tables with rectangular, square and round shape. The top 15 mm thick tempered is available in transparent, transparent extralight, glossy lacquered glass. The cylindrical feet are in transparent borosilicate glass.

Finishes: transparent glass / transparent extralight glass / glossy lacquered glass







INDEX ←





Scrittoio in cristallo trasparente extralight, temperato e termosaldato, disponibile in due diverse misure. Disponibile con la barra poggia piedi in legno di frassino naturale. La grande cura dei dettagli e le calibrate proporzioni conferiscono un aspetto di delicata armonia.



Dimensioni:

PIR01 L 110 P 49 H 83

PIR02 L 80 P 49 H 83



Writing desk in transparent extralight glass tempered and thermo-welded. Available in two different sizes. Available with the footrest bar in natural ash. The great care of the details and the balanced proportions endow an appearance of delicate harmony.

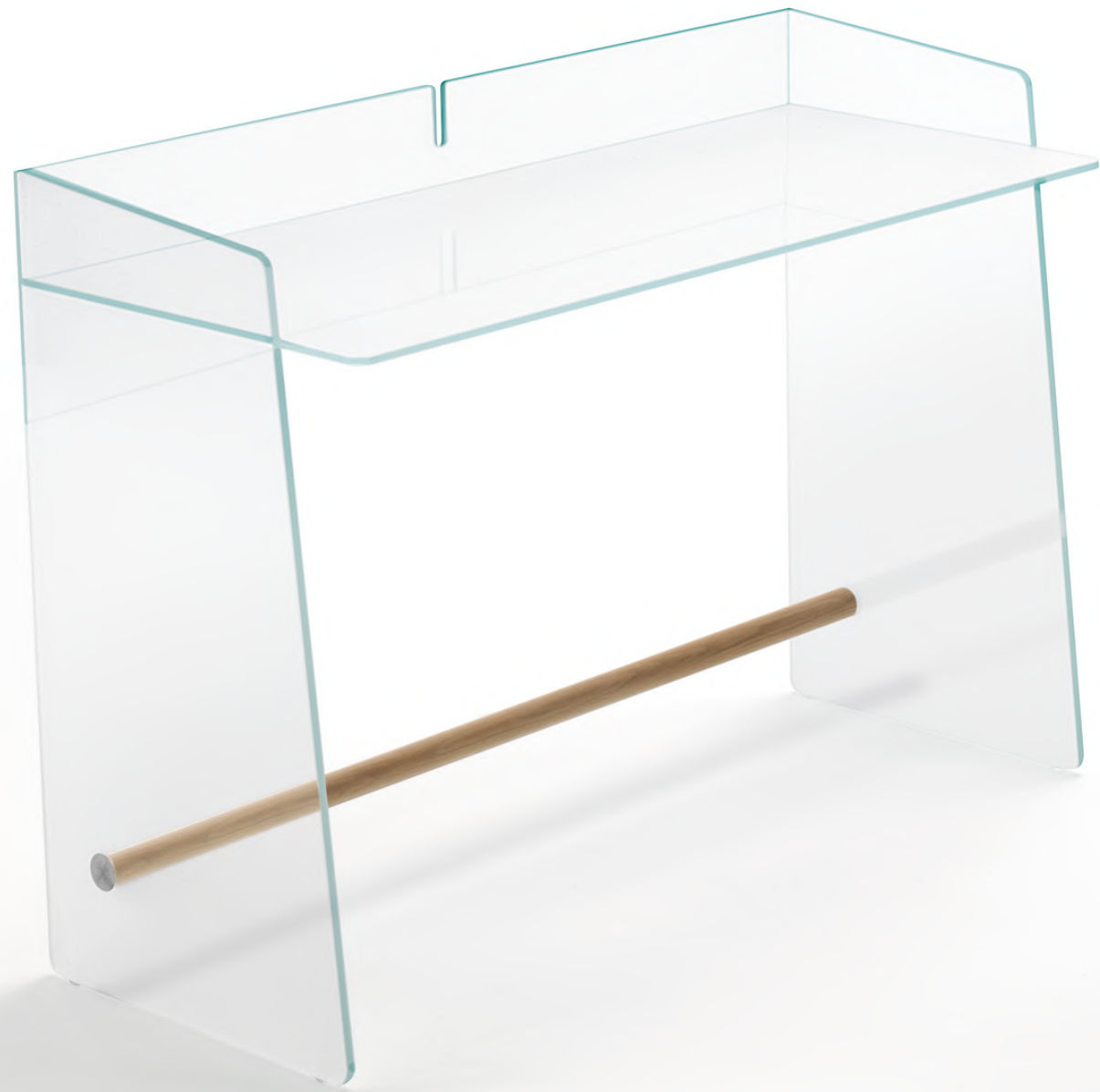



INDEX ←





Tavolo basso estremamente funzionale, dall'aspetto leggero e dalle forme morbide e gentili in cristallo trasparente extralight 12 mm, sagomato e piegato grazie ad un complesso processo di curvatura, ottenendo così due piani a sbalzo, separati da un pratico vano in cui riporre gli oggetti. Al centro è posizionato un elemento con funzione di porta riviste, in cristallo curvato a V capovolta, disponibile nei colori trasparenti rosso rubino, blu, verde smeraldo o trasparente extralight.

Finiture: cristallo trasparente extralight / cristallo colorato

Dimensioni: **PLI01** ø 100 H 40

Extremely functional low table with a light aspect and soft and gentle shapes in 12 mm extralight glass, shaped and curved thanks to a complex process of glass bending, obtaining two cantilevered tops separated by a practical compartment where objects can be stored. Positioned in the centre is a functional magazine rack element made of curved glass with a reversed-V shape, available in the transparent colours ruby red, blue, emerald green or transparent extralight.

Finishes: transparent extralight glass / coloured glass



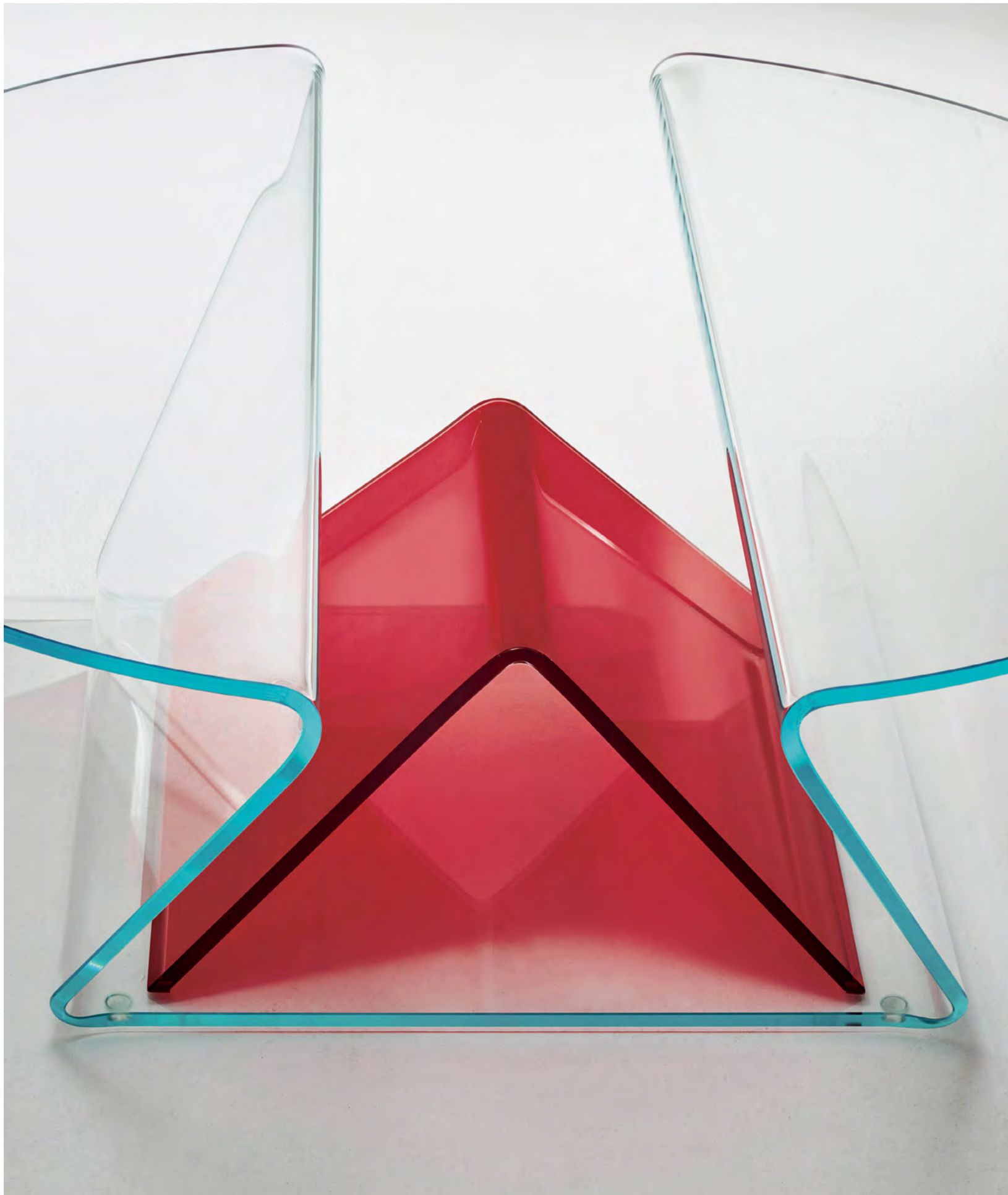



INDEX ←



Serie di tavoli alti e bassi di forma quadrata, rettangolare e rotonda. Il piano è disponibile in cristallo trasparente, trasparente extralight o laccato lucido. Le gambe sono in cristallo borosilicato tornito e sagomato.

Finiture: cristallo trasparente / cristallo trasparente extralight / cristalli laccati lucidi



Dimensioni:

POS01 L 180 P 90 H 72	POS13 L 110 P 110 H 38
POS02 L 200 P 90 H 72	POS14 L 120 P 120 H 38
POS03 L 200 P 100 H 72	POS15 L 130 P 130 H 38
POS04 L 210 P 90 H 72	POS16 L 130 P 70 H 38
POS05 L 210 P 100 H 72	POS17 L 140 P 80 H 38
POS06 L 220 P 90 H 72	POS18 L 160 P 80 H 38
POS07 L 220 P 100 H 72	POS19 ø 120 H 38 <i>con 3 gambe / with 3 legs</i>
POS08 L 130 P 130 H 72	POS20 ø 140 H 72 <i>con 3 gambe / with 3 legs</i>
POS09 L 140 P 140 H 72	POS21 ø 150 H 72 <i>con 3 gambe / with 3 legs</i>
POS10 L 150 P 150 H 72	POS22 ø 160 H 72 <i>con 3 gambe / with 3 legs</i>
POS11 L 90 P 90 H 38	POS23 ø 170 H 72 <i>con 3 gambe / with 3 legs</i>
POS12 L 100 P 100 H 38	



Series of high and low tables with squared, rectangular and rounded shape. The top is available in transparent, transparent extralight or glossy lacquered. The feet are in molded and shaped borosilicate glass.

Finishes: transparent glass / transparent extralight glass / glossy lacquered glass







INDEX ←





Tavolo in cristallo trasparente extralight 12 mm argentato. Grazie ai riflessi dello specchio e alle speciali molature e bisellature dei bordi del cristallo, il tavolo assume una preziosa luminosità e brillantezza. Le basi sono fissate al piano per mezzo di piastre metalliche e viti.

Dimensioni: **PRT01** L 240 P 90 H 73

Table in transparent extralight 12 mm thick silver plated glass. Thanks to the reflections of the mirror and to the special grinding and bevelling of the glass edges, the table acquires a precious brilliance and shine. The bases are fixed to the top by means of metal plates and screws.







INDEX ←



Piccola scrivania composta da scatole in cristallo fumé 10 mm temperato, incollato a 45°, sovrapposte a sbalzo e fissate tra di loro per mezzo di minimali giunti in alluminio anodizzato nero. La scatola del top contiene un cassetto in massello di frassino tinto nero, che appoggia e scivola sul vetro grazie a degli inserti di vellutino. Degli invisibili fermi di sicurezza evitano la caduta del cassetto. Le altre scatole, utilizzabili come vani porta oggetti, sono disponibili realizzate completamente in vetro fumé o con schienale nelle finiture dei "Cristalli Trasparenti Colorati". Una gamba cilindrica in massello di frassino tinto nero opaco sostiene lateralmente il top, impedendo il ribaltamento dello scrittoio.



Dimensioni: **RAT01** L 115 P 40 H 104,5



Small desk made up of 10 mm tempered smoked glass boxes, glued at 45°, cantilevered and overlapped, fixed to each other by means of minimal black anodized aluminum joints. The top box contains a drawer in solid black stained Ash, which rests and slides on the glass thanks to velvet inserts. Invisible safety stops prevent the drawer from falling. The other boxes, which can be used as storage compartments, are available made entirely of smoked glass or with a back panel in the "Colored Transparent glass" finishes. A cylindrical leg in solid matt black Ash supports the top laterally, preventing the desk from tipping over.





← INDEX



Collezione composta da un tavolo basso e da una consolle con una struttura in legno completamente rivestita da un mosaico di piastrelle in vetro colato dalle colorazioni variegata e irregolari. Le piastrelle sono sagomate e posizionate in modo che il piano riproduca la proiezione assonometrica di un parallelepipedo. I pezzi sono completati da dei funzionali cassetti invisibili con sistema di apertura push-pull.



Dimensioni:

REM01 L 100 P 80 H 32

REM02 L 120 P 44 H 85

Collection composed by a low table and a console with a wooden structure completely covered by a mosaic of cast glass tiles in various and random colours. The tiles are shaped and positioned so that the surface reproduces the axonometric projection of a parallelepiped element. The pieces are completed by functional invisible drawers with a push-pull opening system.



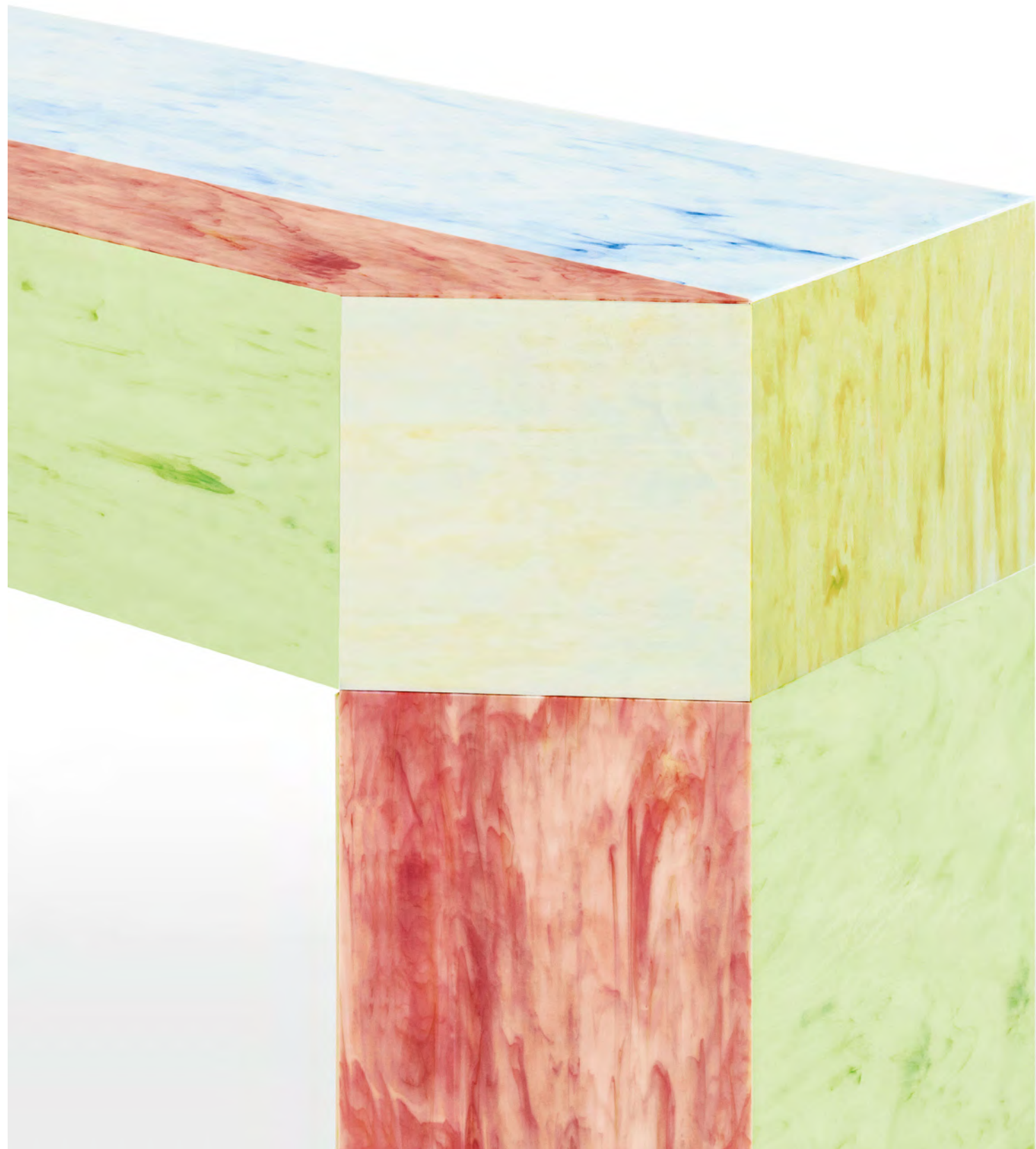





INDEX ←



Collezione di tavoli bassi, consolle e mobile contenitore completamente realizzati in uno speciale cristallo specchiante su entrambe le facce, con un pattern decorativo a bolli trasparenti, che simula una lamiera traforata. Tutti i cristalli sono temperati e incollati a UV. Il contenitore è chiuso da due antine con sistema di chiusura push-pull.



Dimensioni:

ROB01 L 132 P 41 H 79
ROB03 L 56 P 41 H 55

ROB04 L 112 P 112 H 35
ROB05 L 120 P 85 H 35



Collection of low tables, consoles and storage furniture, completely created from a special double-sided mirrored glass, with a decorative pattern made from round transparent marks, simulating a perforated metal sheet. All the glass is tempered and UV bonded. The two doors are opened and closed with a push-pull system.

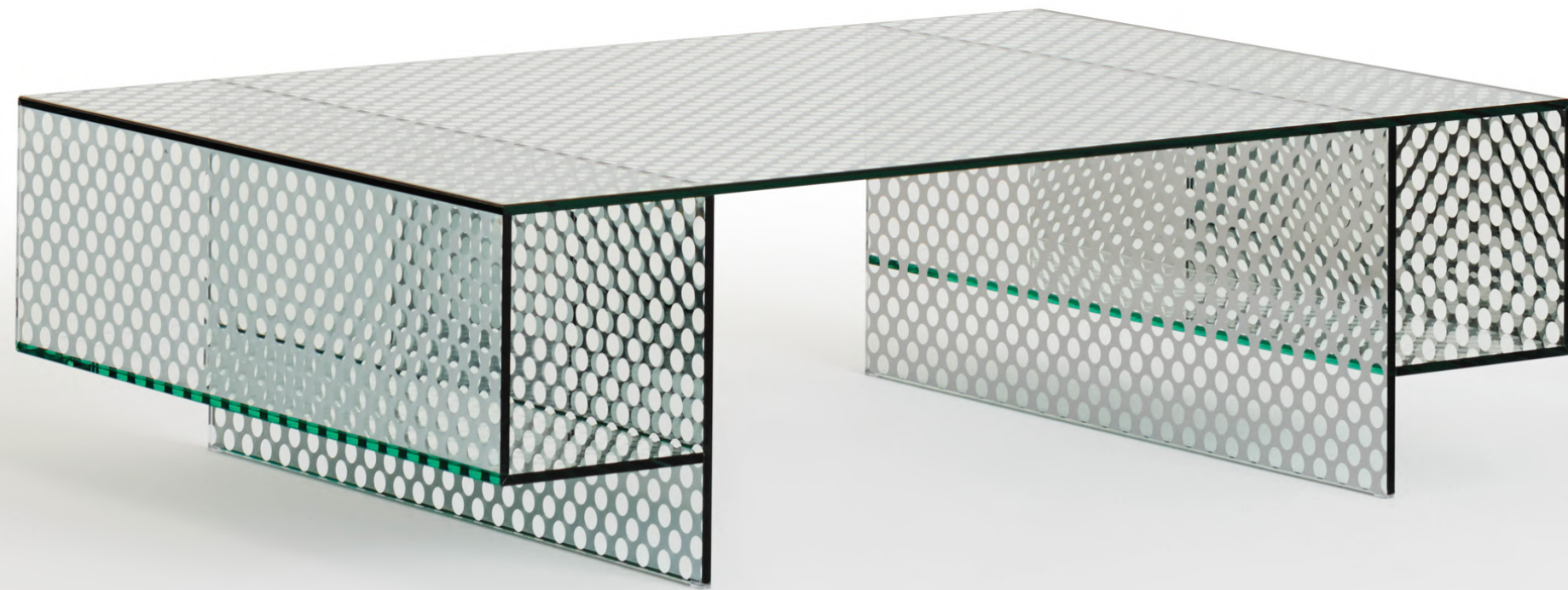





INDEX ←



Tavolo basso realizzato completamente in cristallo trasparente extralight, temperato e incollato, con al centro una vasca di contenimento. Il doppio piano permette di alloggiare all'interno del tavolino oggetti di vario genere, mentre la vasca, grazie ad un incollaggio che garantisce la tenuta dell'acqua, può essere utilizzata come vaso, fioriera o acquario. E' disponibile anche una versione con bruciatore in acciaio inox alimentato da bioetanolo.



Dimensioni:

SEA01V L 120 P 120 H 33
con vasca/with basin

SEA01B L 120 P 120 H 33
con bruciatore/with burner



Low table realized completely in tempered and glued transparent extralight glass. A retaining basin is placed in the centre. The double top allows various objects to be placed inside the low table, whilst the basin which is watertight through a special gluing, can be used as vase, flower box or aquarium. A version with a burner in steel inox fuelled by bioethanol is also available.







INDEX ←



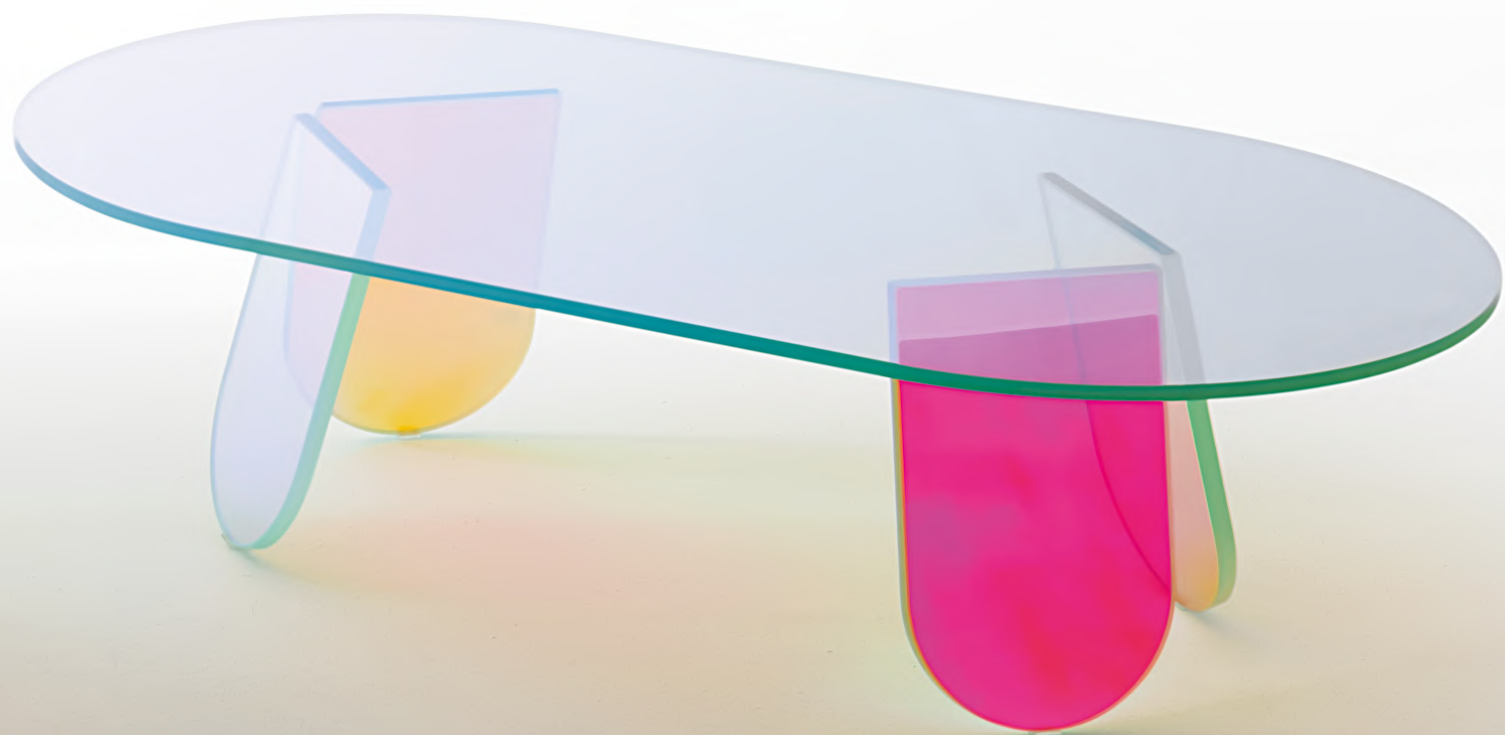

Tavoli alti, bassi e consolle in cristallo stratificato e incollato, con una speciale finitura multicro-
matica cangiante, la cui colorazione varia in funzione dell'angolo di incidenza della luce e del
punto di osservazione. Ne risultano oggetti dall'aspetto magico ed etereo. Per i codici da SHI01
a SHI07 le gambe sono incollate al piano, mentre nei tavoli alti sono smontabili e vengono fis-
sate ai piani tramite piastre metalliche, dissimulate da decori circolari con finitura coprente. Per i
codici da SHI14 a SHI26 il piano è in appoggio sulla base. Nella consolle SHI23 è inoltre fissato
alla parete con dei fermi metallici.



Dimensioni:					
	SHI01	ø 52	H 45	ovale	SHI16 L 120 P 90 H 41
	SHI02	ø 65	H 50	ovale	SHI17 L 180 P 115 H 73
	SHI03	L 120 P 65	H 35		SHI18 ø 120 H 73
	SHI07	L 100 P 45	H 84,5		SHI19 L 120 P 120 H 73
	SHI08	ø 95	H 74		SHI20 L 180 P 100 H 73
	SHI09	ø 105	H 74		SHI21 L 180 P 120 H 73
	SHI10	ø 120	H 74		SHI22 L 120 P 90 H 73
	SHI11	ø 130	H 74	consolle	SHI23 L 120 P 42 H 85
	SHI12	ø 140	H 74		SHI24 L 120 P 120 H 36
ovale	SHI13	L 240 P 130	H 74		SHI25 ø 120 H 36
ovale	SHI14	L 60 P 50	H 51		SHI26 L 120 P 90 H 36
ovale	SHI15	L 90 P 60	H 46		



High tables, low tables and consoles in laminated and glued glass, characterized by a special
iridescent multichromatic finish; the nuance varies according to the angle of the light source
and the vantage point. Reflected objects with a magical and ethereal appearance emerge. For
the codes from SHI01 to SHI07 the legs are glued to the top, while in the high tables they are
removable. The high tables bases can be dismantled and are fixed to the top by means of metal
plates, concealed by a circular decorated covering. For the codes from SHI14 to SHI26 the top
rests on the base. In the SHI23 console it is also fixed to the wall with metal brackets.

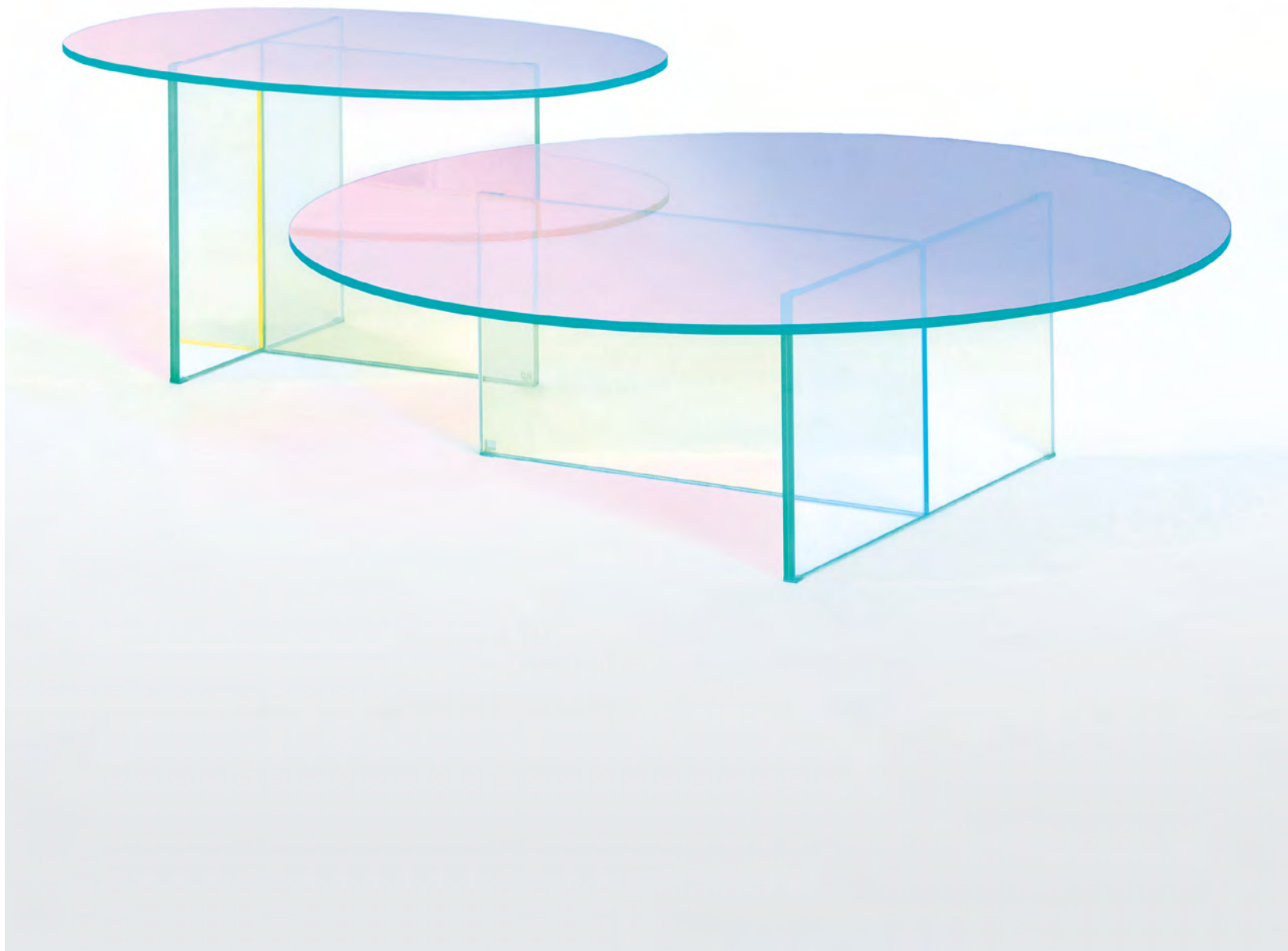

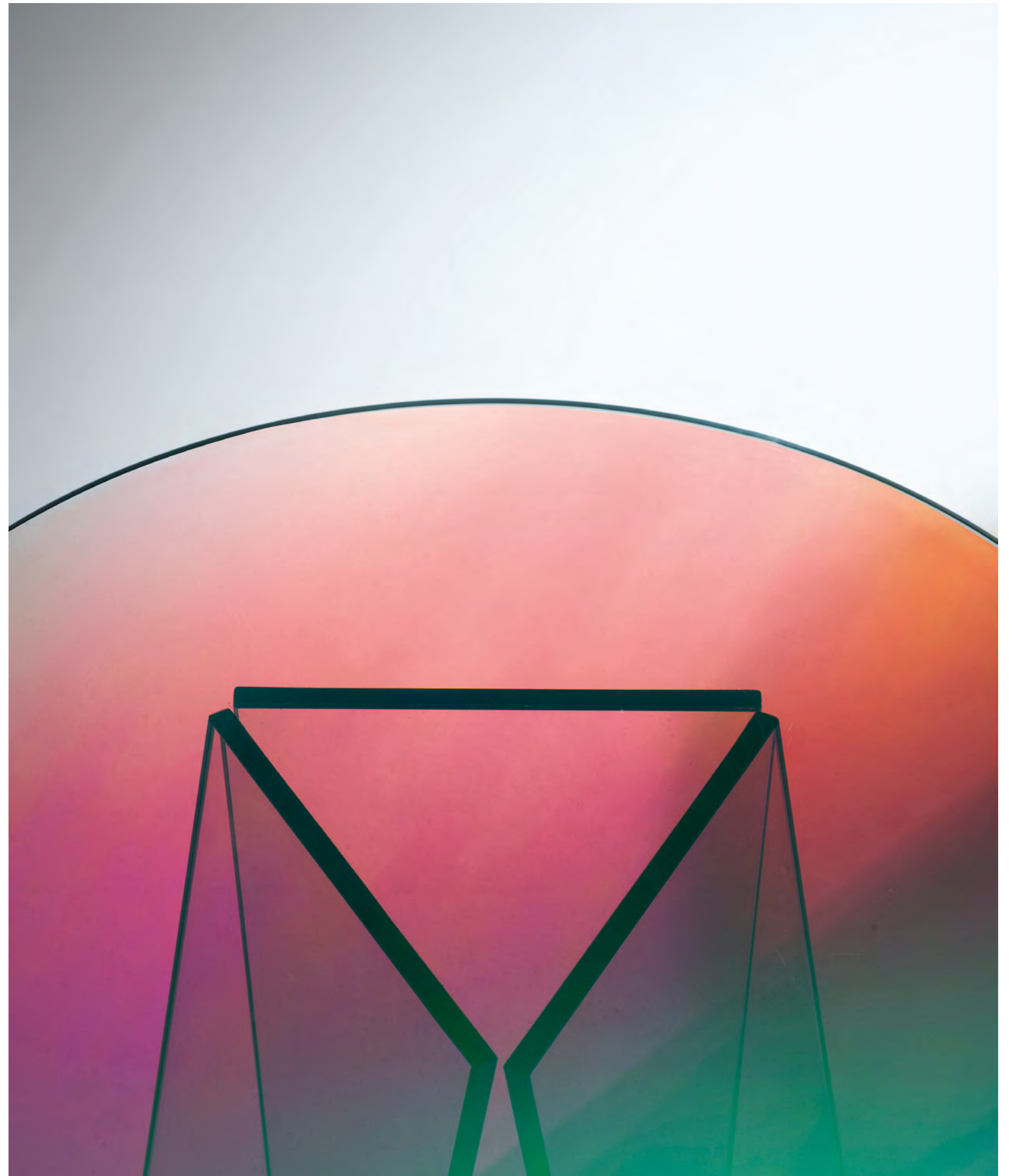

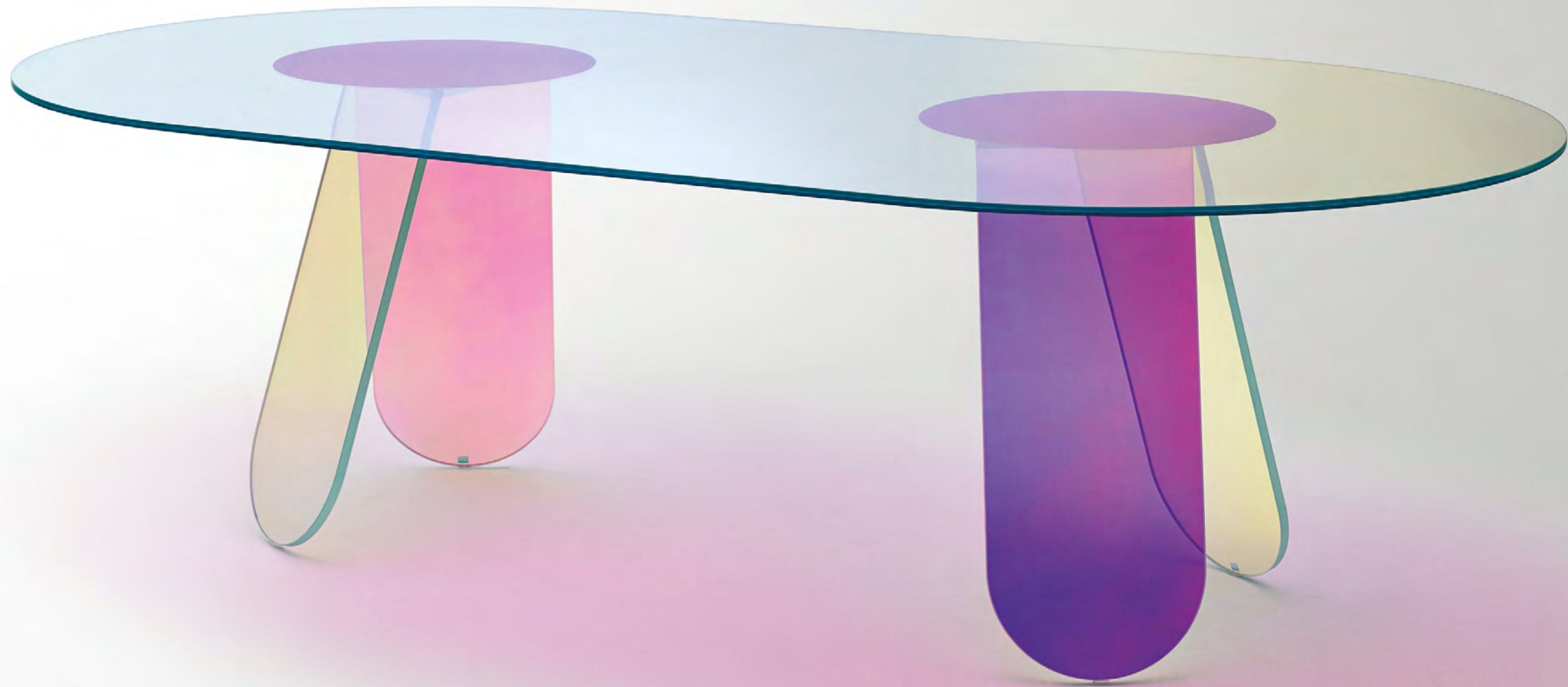





INDEX ←



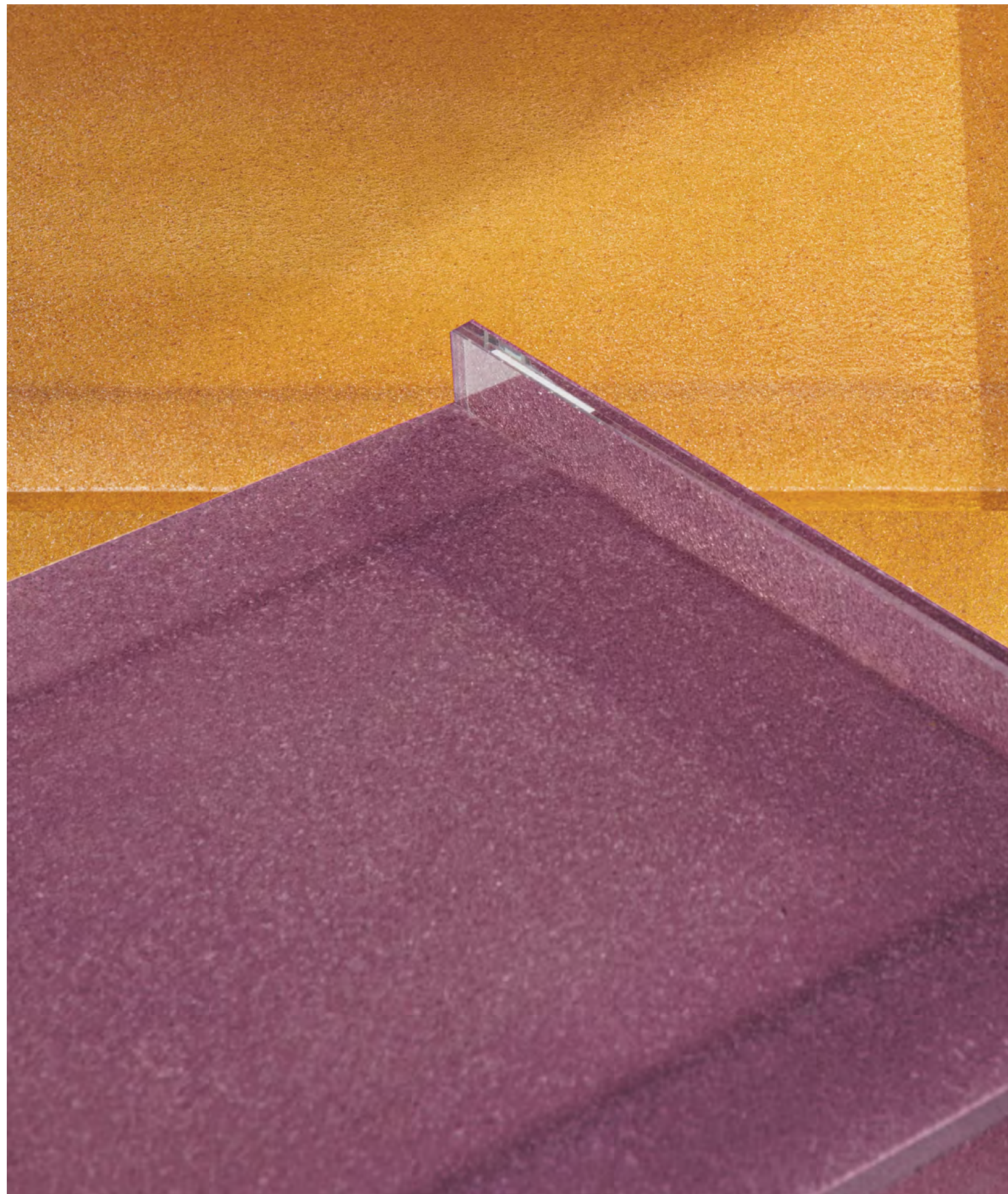

Serie di tavoli bassi, alti, consolle e scrittoio realizzati incollando a UV lastre di cristallo extralight 12 mm molato filo lucido, la cui superficie è rivestita con una speciale graniglia in vetro di Murano macinato, disponibile nei colori ametista, blu chiaro e topazio.



Dimensioni:

SIM01 L 120 P 83 H 42
SIM02 L 90 P 92 H 42
SIM03 L 50 P 52 H 59
SIM04 L 250 P 110 H 74
SIM05 ø 140 H 74
SIM06 L 140 P 140 H 74

SIM07 L 160 P 160 H 74

desk **SIM08** L 110 P 51 H 74 (h top)

consolle **SIM09** L 130 P 42 H 80 (h top)

SIM10 ø 80 H 40

SIM11 ø 45 H 50



Collection of low, high and console tables plus a writing desk made by UV bonding 12 mm thick ground polished extralight glass slabs, which surface is coated with a special grit in ground Murano glass, available in amethyst, light blue and topaz colors.













■ ← INDEX



Serie di tavoli bassi console e scrivania a ponte in cristallo stratificato accoppiato. Disponibili in cristallo laccato lucido o laccato opaco, con la possibilità di combinare liberamente il colore della parte inferiore con quello della parte superiore.

Finiture: cristalli laccati lucidi / cristalli laccati opachi

Dimensioni:

TAPO03	L 110	P 110	H 30	TAPO06	L 180	P 80	H 72
TAPO04	L 130	P 70	H 30	TAPO08	L 160	P 80	H 72
TAPO05	L 130	P 35	H 75	TAPO09	L 140	P 80	H 72

Series of bridge-shaped low tables console and desk in coupled laminated glass. Available in glossy lacquered and opaque lacquered glass, with the possibility to combine freely the colour of the lower side with the colour of the upper side.

Finishes: glossy lacquered glass / opaque lacquered glass

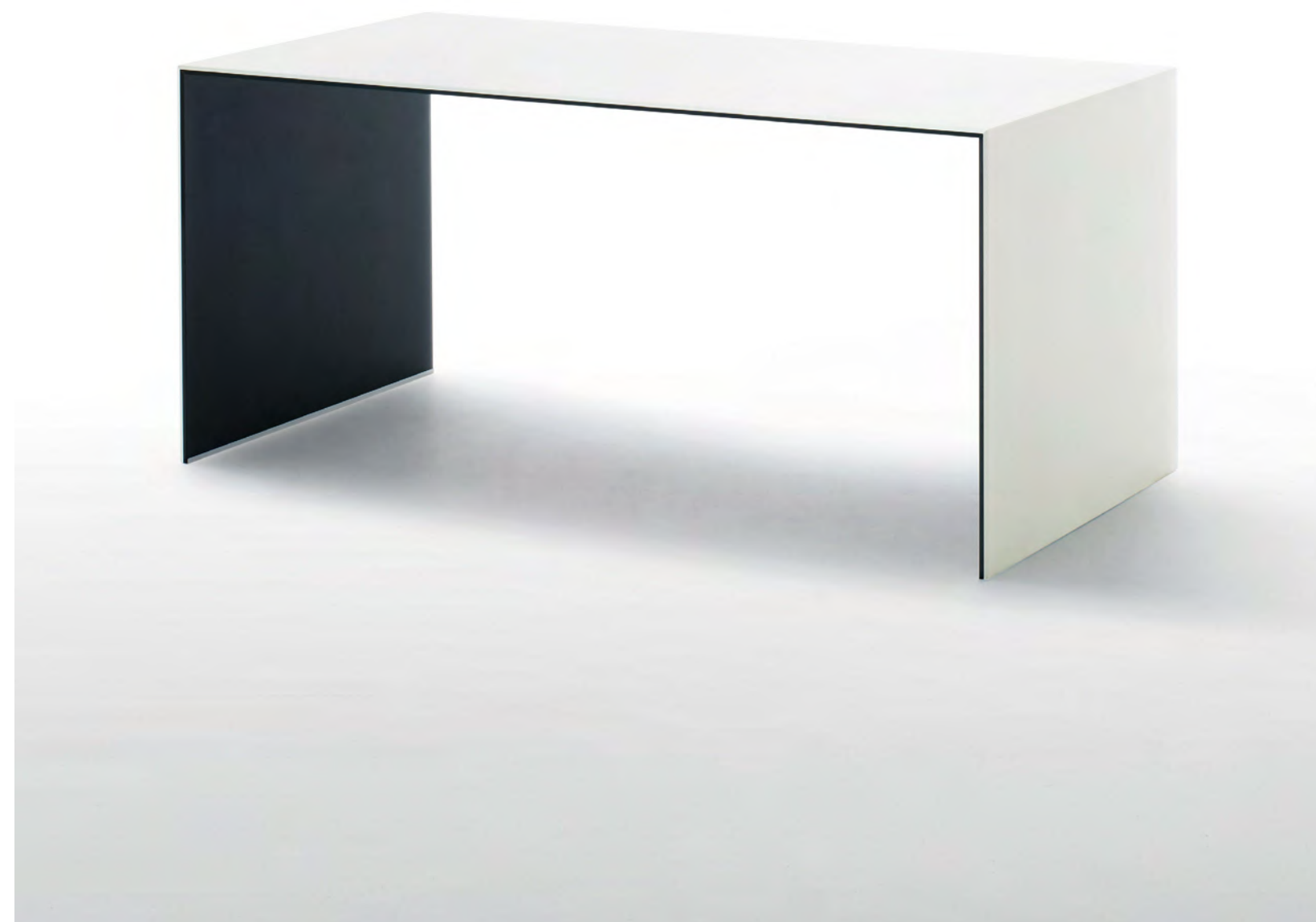





■ ← INDEX



52 / SiO₂ - Tunnel _ Piero Lissoni, Marc Krusin,
Carlo Tamborini



Serie di tavoli bassi con doppio ripiano in cristallo stratificato accoppiato. Disponibili in cristallo laccato lucido e laccato opaco, con la possibilità di combinare liberamente il colore dell'interno con quello dell'esterno. Piedini in alluminio.

Finiture: cristalli laccati lucidi / cristalli laccati opachi



Dimensioni: **TATU01** L 110 P 110 H 32 **TATU02** L 130 P 70 H 32



Series of low tables with double plate in coupled laminated glass. Available in glossy lacquered and opaque lacquered glass, with the possibility to combine freely the colour of the inside with the colour of the outside. Small feet in aluminium.

Finishes: glossy lacquered glass / opaque lacquered glass





■ ← INDEX





Collezione di tavoli, consolle e di tavoli bassi dalle forme morbide ed irregolari con bordo arrotondato ed eleganti esili gambe in cristallo soffiato. I diversi pezzi, usufruibili in maniera indipendente tra di loro, se accostati danno forma ad un tavolo dalle grandi dimensioni. Con piani in uno speciale vetro colato argentato. Le gambe sono sempre nella stessa finitura del piano.

Dimensioni:

SDV02 L 132 P 67 H 72
SDV03 L 124 P 149 H 72
SDV04 L 135 P 57 H 72

SDV08 L 132 P 67 H 38
SDV09 L 124 P 149 H 38
SDV10 L 135 P 57 H 38

Collection of high tables, consoles and low tables with soft irregular shape, rounded edge and elegant thin legs in blown glass. The different pieces, available independently from each other, if put close together, can create a table of large dimensions. With top in a special poured silvered glass. The legs are always in the same finish of the top.





INDEX ←





Sofisticato composito tavolo basso a forma di vasca, realizzata incollando a 45° lastre di cristallo stratificato di diverse qualità e finiture. Il fondo è in specchio, mentre i quattro fianchi sono realizzati nei seguenti materiali: cristallo stampato Flutes, cristallo stampato Quadretti, cristallo con tessuto Masaccio o Botticelli (a scelta), cristallo trasparente colorato (a scelta tra 12 colori), cristallo trasparente extrachiario. Il tavolino è poi completato da un piano in appoggio, posizionabile a piacimento, in cristallo trasparente extralight o trasparente colorato (a scelta tra 12 colori).

Dimensioni:

SPE01 L 100 P 100 H 31

SPE02 L 100 P 50 H 31

Sophisticated composite low table in shape of a tub, made by bonding 45 ° laminated glass slabs, different in quality and finish. The bottom is mirrored, whilst the four sides are made of the following materials: Flutes printed glass, Quadretti printed glass, glass with Masaccio or Botticelli fabric (by choice), transparent colored glass (choice of 12 colors), extralight transparent glass. The coffee table is then completed with a support surface, that can be positioned as desired, in transparent extralight or transparent colored glass (choice of 12 colors).



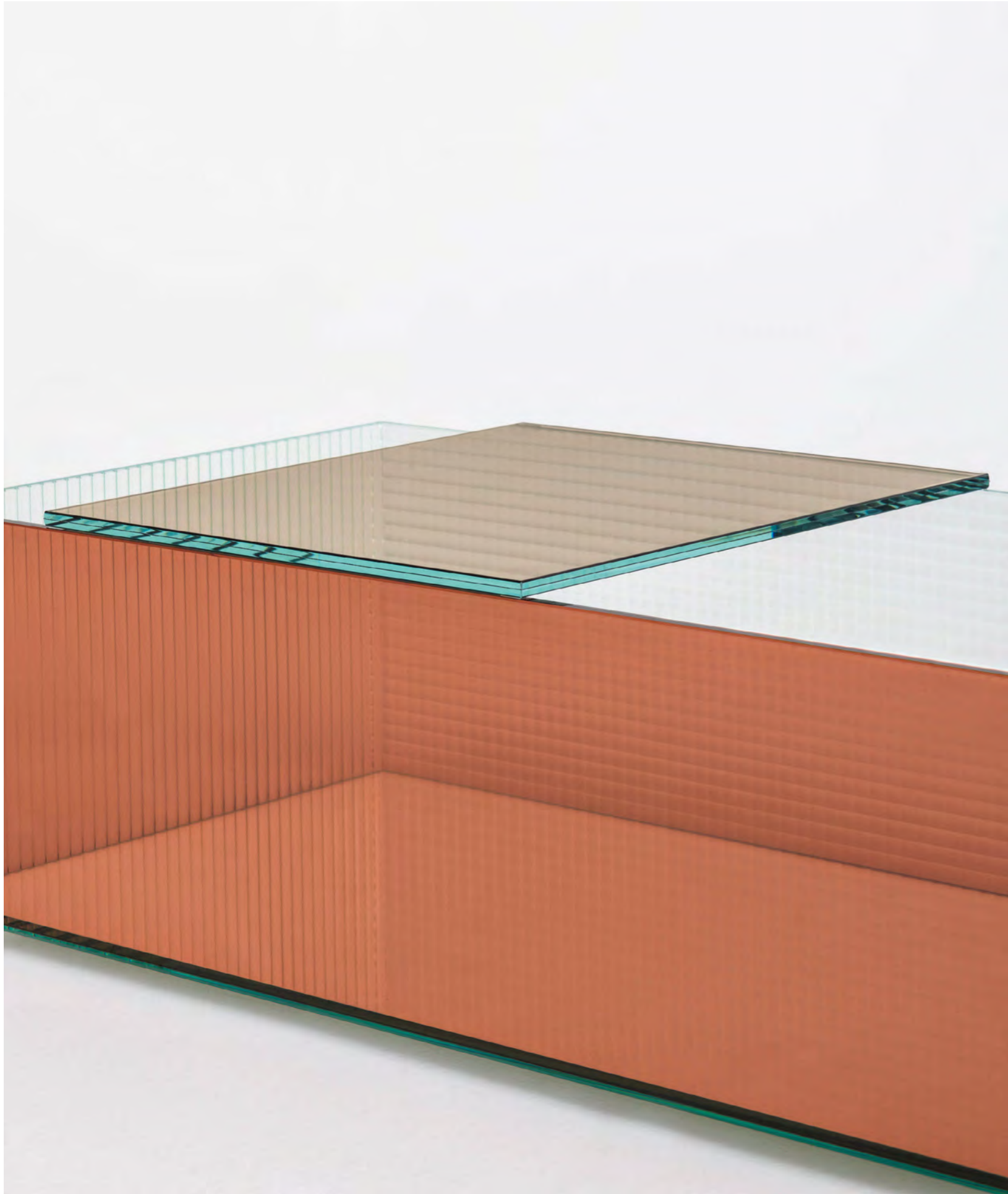





INDEX ←





Scrivania con gambe in cristallo extrachiario 15 mm curvato che sostengono un top fornito di cassetto con apertura push-pull, completamente rivestito in cristallo temperato, laccato lucido o opaco, giuntato a 45°. Il fondo del cassetto è in cristallo nella stessa finitura dell'esterno. Nel top è presente una fresata passacavi, in cui può essere inserito uno specchio bifacciale, trasformando così la scrivania in una moderna toeletta.

Finiture: laccati lucidi / laccati opachi

Dimensioni: STRA01 L 125 P 48 H 77

Writing desk in extra light 15 mm thick glass with curved glass legs supporting a top with a touch latch (push-pull) drawer, completely covered in tempered glass, lacquered matt or glossy, glued 45°. The bottom of the drawer is in the same glass finish as the desk. On the top of the desk there is a special casing milled to house cables with the possibility of slotting in a double-faced mirror to transform the desk into a modern make-up desk.

Finishes: glossy lacquered / matt lacquered







■ ← INDEX





Tavolo basso composto da un parallelepipedo in pietra Limestone di aspetto monolitico e un elemento in cristallo trasparente extralight 15 mm temperato, incollato a 45°, che va in appoggio sullo stesso. Il parallelepipedo in pietra ha i fianchi con finitura a spacco, mentre il piano è fiammato. La matericità, la gravità e la solidità della pietra si incontrano con la leggerezza, la purezza e l'etereità del cristallo.

Dimensioni: **TERL01** L 185 P 100 H 23

Low table composed of a parallelepiped Limestone stone with a monolithic appearance and an element in tempered 15 mm. thick glued 45° transparent extralight glass that rests on it. The stone parallelepiped has the sides in a split-face finish, whereas the top is flamed. The materiality, the gravity and the solidity of the stone juxtapose the lightness, the purity and the ethereality of the glass.







INDEX ←



57 / The Dark Side of the Moon Striped / Faded

Piero Lissoni

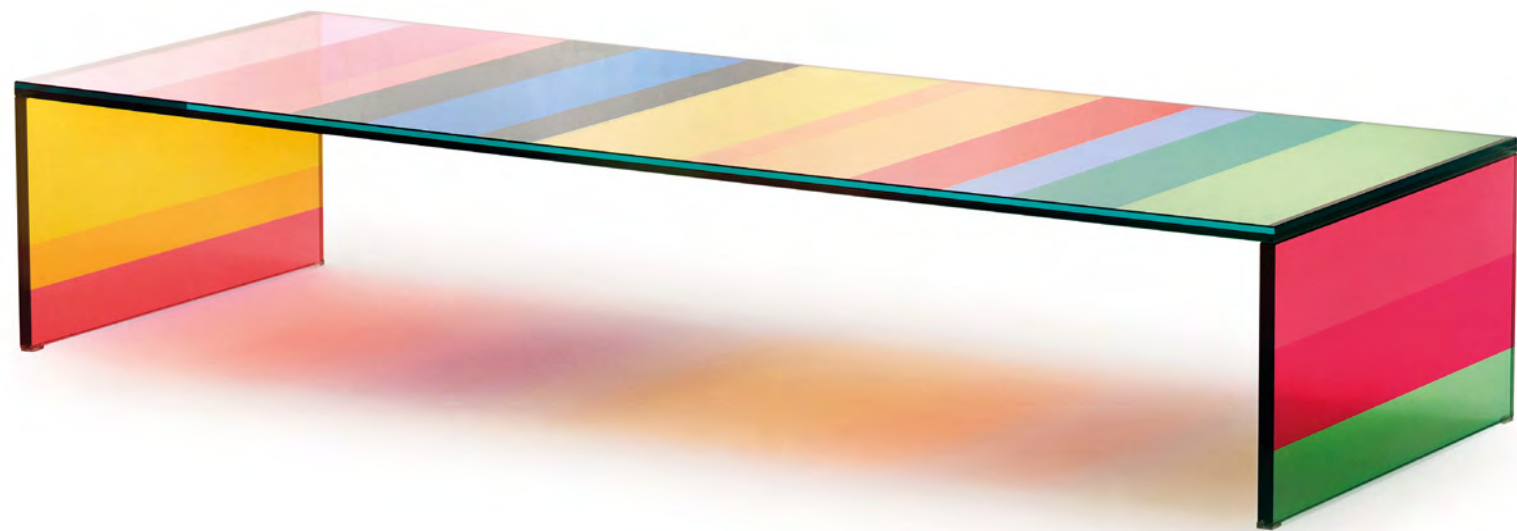

Tavolo basso a ponte in cristallo extralight stratificato con una sofisticata tecnica di lavorazione, grazie alla quale il piano e i fianchi sono caratterizzati da una finitura multicromatica. Disponibile in due versioni: una a strisce, l'altra a tinte sfumate.



Dimensioni:

THE09C

L 155 P 55 H 30

THE09S

L 155 P 55 H 30



Low table with bridge shape in laminated transparent extralight glass with a sophisticated and innovative technical process, thanks to which the top and sides are characterized by a multi coloured finish. Available in two versions: one is striped, and the other one with faded colours.



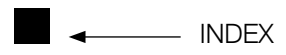



Tavolo composto da volumi scatolati in cristallo trasparente extralight 10 mm temperato, ottenuti grazie a complesse lavorazioni di incollaggio. Il piano, a forma di parallelepipedo aperto sulle due estremità, è sorretto da due basi a forma di "T". Ne risulta un tavolo di grande rigore e purezza formale e al contempo dall'importante presenza volumetrica.

Dimensioni:

VER01 L 300 P 100 H 77

VER02 L 250 P 90 H 77

Table constructed from boxed volumes in 10 mm thick transparent extralight tempered glass, obtained thanks to complex gluing manufacturing. The top is supported by two "T" shaped bases and it has a parallelepiped shape opened on the two extremities. The result is a table of great strength and formal purity and at the same time characterized by the great volumetric presence.



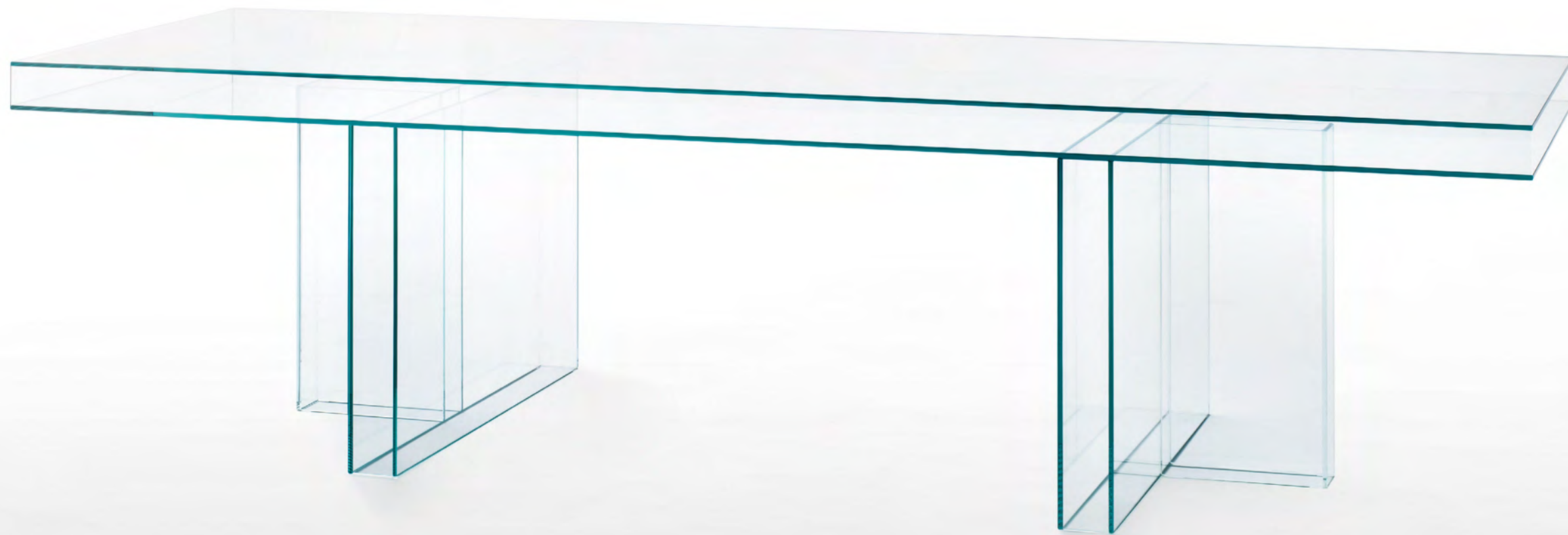



INDEX ←



Serie di tavoli bassi a forma di parallelepipedi storti ed irregolari, realizzati incollando lastre di cristallo trasparente extralight temperato, i cui bordi presentano angoli di molatura con inclinazioni totalmente differenti tra di loro. Ne risultano dei tavolini apparentemente instabili e dall'equilibrio precario. Gli spigoli vengono messi in evidenza da una linea colorata nella finitura dei cristalli laccati lucidi.

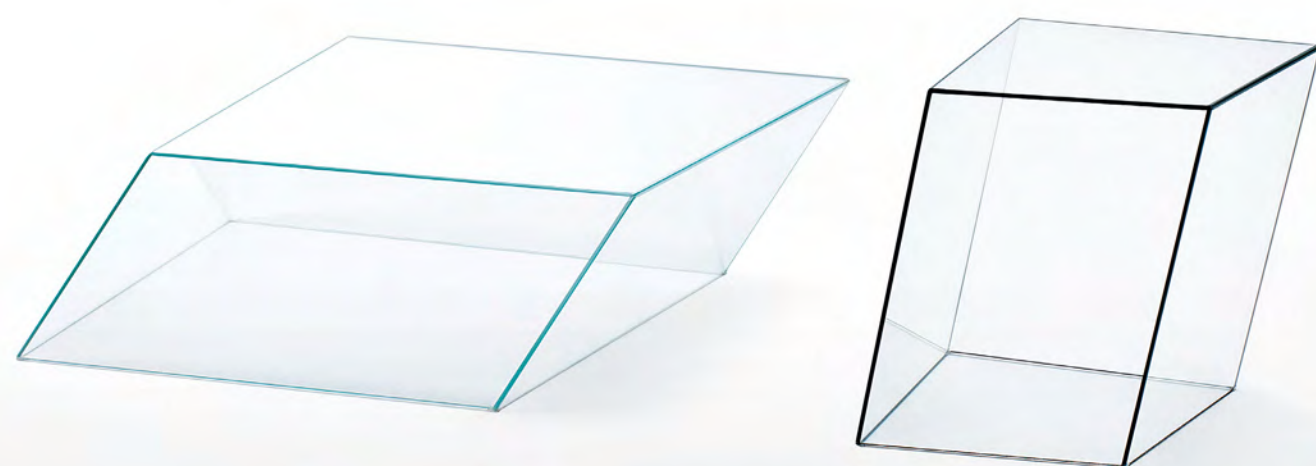

Dimensioni:

WIR01 L 40 P 38 H 45
WIR02 L 75 P 87 H 25

WIR03 L 60 P 57 H 30

A series of twisted and irregular, parallelepiped shaped low tables, obtained by gluing tempered transparent extralight glass slabs, whose edges have grinding angles with each of their inclinations completely different from the other ones. The result is an apparently unstable and precariously balanced low table. The edges are enhanced by a coloured line in glossy lacquered glass.



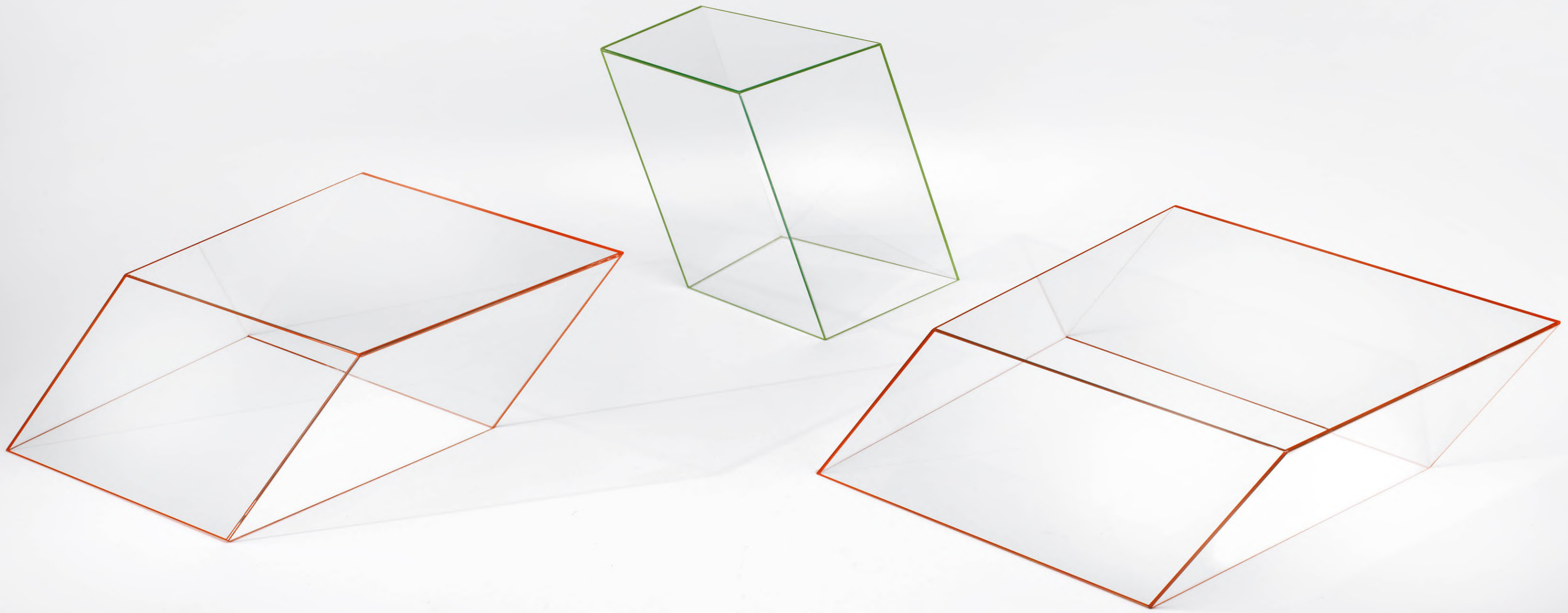



INDEX ←



Tavolo alto di forma quadrata, rotonda, ovale o rettangolare con piano in cristallo trasparente extralight 15 mm, oppure in cristallo fumè o blu in pasta stratificato 8+8 mm. Le gambe, in cristallo extrachiario, fumè o blu in pasta 10 mm temperato, incollato a UV, sono smontabili e fissate al piano tramite sofisticate coppie di piastre, realizzate in acciaio inox lucidato a specchio. Il tavolo è rifinito inferiormente da quattro piedini in acciaio inox lucidato a specchio, perfettamente integrati nella sagoma delle gambe. È disponibile anche la versione consolle.

Dimensioni:

XTA01	L 200	P 100	H 74	XTA10	L 160	P 160	H 74
XTA02	L 220	P 100	H 74	XTA11	L 240	P 110	H 74
XTA03	L 250	P 100	H 74	ovale XTA12	Ø 140		H 74
XTA04	L 280	P 100	H 74	XTA13	Ø 150		H 74
XTA05	L 300	P 100	H 74	XTA14	Ø 160		H 74
XTA06	L 120	P 120	H 74	XTA15	Ø 170		H 74
XTA07	L 130	P 130	H 74	XTA16	L 160	P 38	H 74
XTA08	L 140	P 140	H 74	XTA17	L 180	P 38	H 74
XTA09	L 150	P 150	H 74	XTA18	L 200	P 38	H 74

High table with square, round, oval or rectangular shape with top in 15 mm thick transparent extralight, smoked glass or in laminated 8+8 mm "blue paste glass". The legs, in 10 mm thick extralight, smoked or blue paste tempered glass, UV-bonded, are removable and fixed to the top by means of sophisticated plates in mirror-polished stainless steel. The table is refined at the bottom by four feet in mirror-polished stainless steel, perfectly integrated into the shape of the legs. A console version is available too.

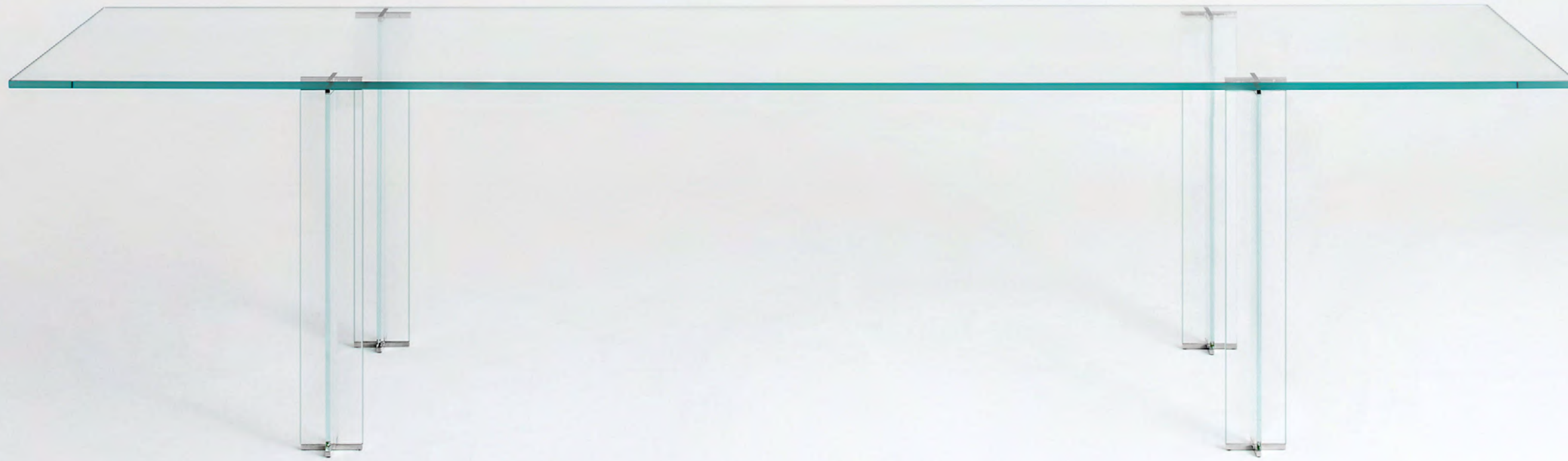

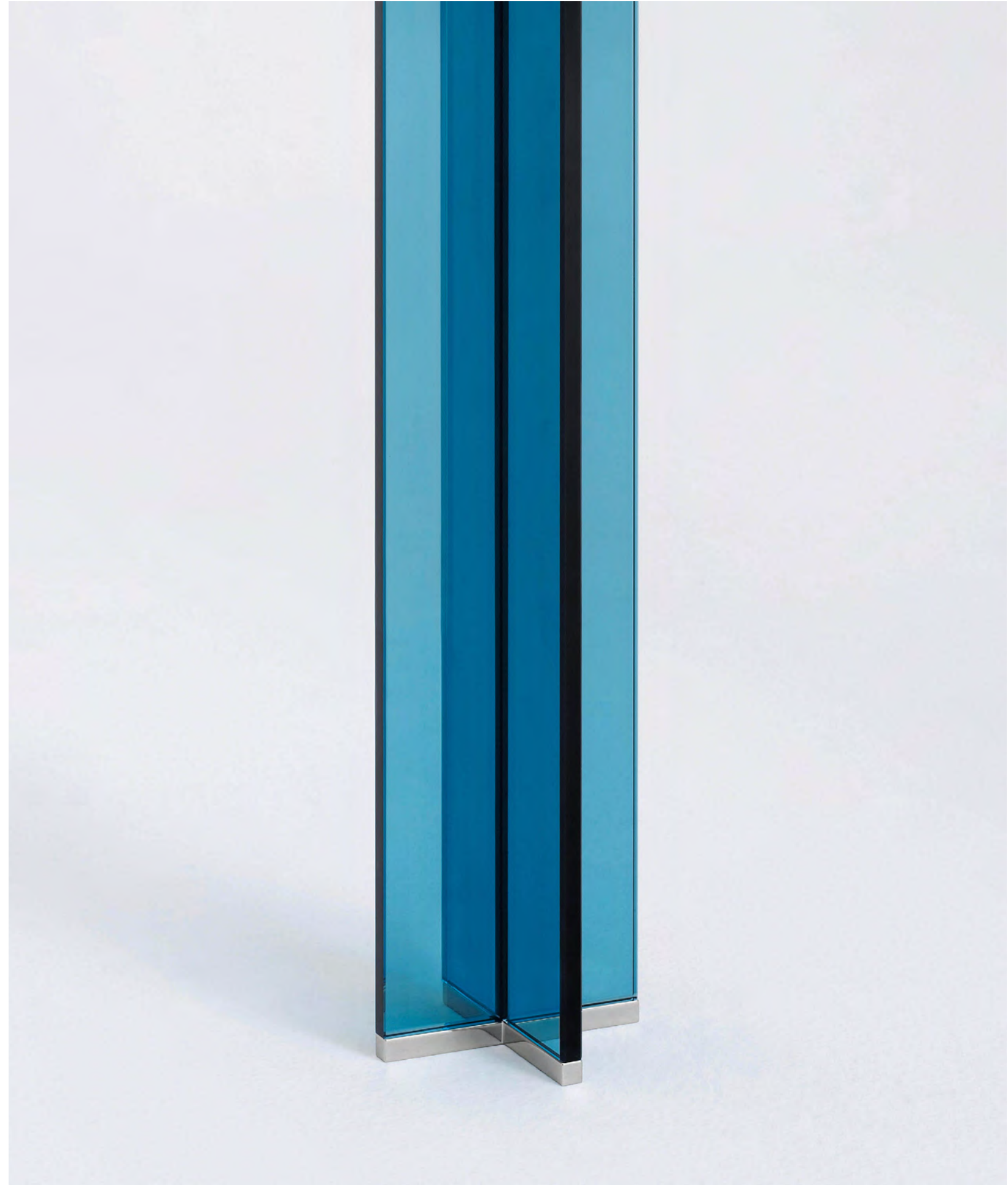



INDEX





61 - XX



Consolle realizzata in cristallo trasparente di colore rosa e arancio. La base composta da due X in cristallo temperato e stratificato 8+8 mm, con speciali bisellature ed incollaggi, è impreziosita da elementi in metallo cromato lucido. Il piano, in cristallo stratificato 8+8 mm, va in appoggio sulla base.

Dimensioni: **XX03** L 175 P 40 H 89



XX

61 - XX

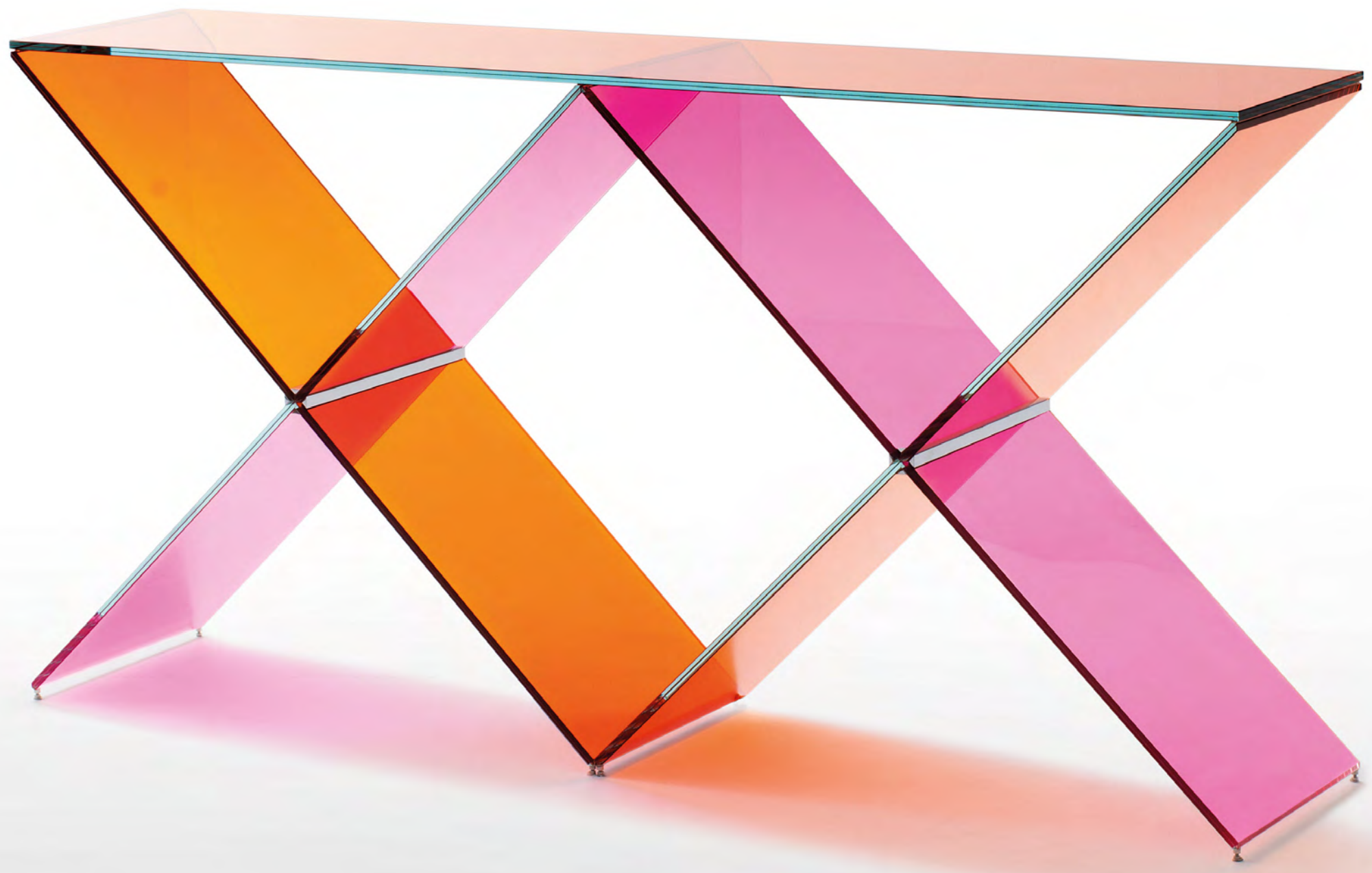



INDEX





Tavolo basso realizzato in cristallo trasparente di colore rosa, arancio e giallo. La base è ottenuta incollando sei lastre di cristallo stratificato 6+6 mm, con speciali bisellature. Il piano, in cristallo stratificato 6+6 mm, va in appoggio sulla base ed è disponibile in uno dei suoi tre colori.



Dimensioni: **XXX01** ø 50 H 40 **XXX02** ø 80 H 30



Low table realized in transparent pink, orange and yellow coloured glass. The base is obtained by gluing six laminated, 6+6 mm thick glass plates with special chamfering. The top, in laminated 6+6 mm thick glass, leans on the base and is available in one of its three colours.

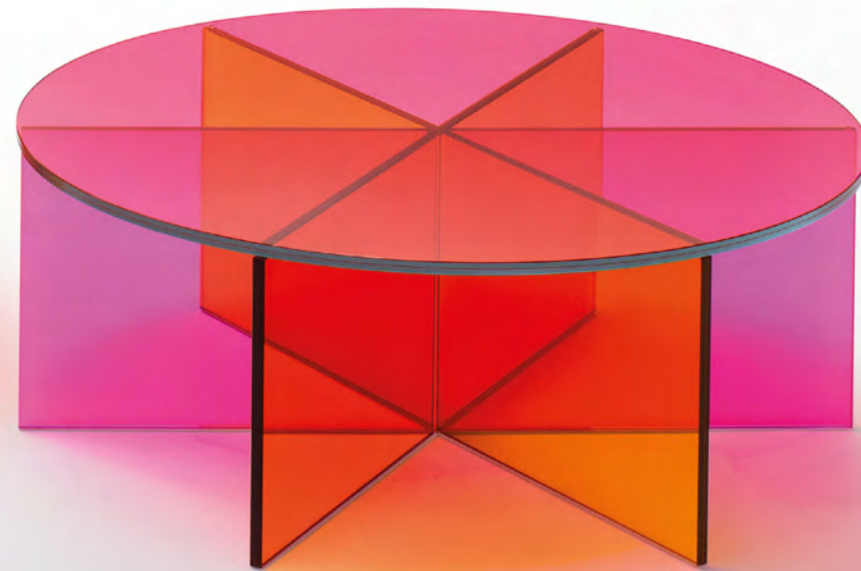
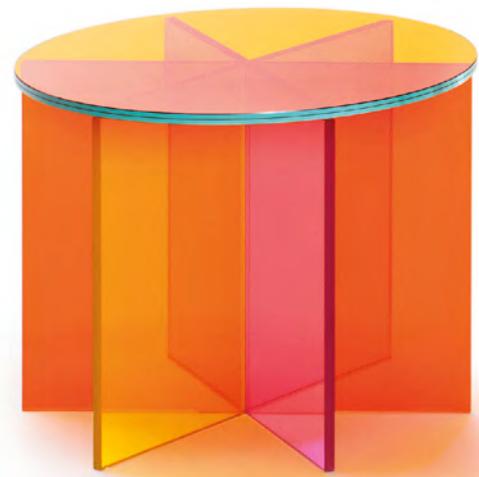

SEDUTE / SEATS



63 / Bent Glass Bench - Bent Glass Stool

Naoto Fukasawa



Panca e sgabello con un aspetto di naturale semplicità, realizzati in cristallo trasparente extralight 12 mm, sagomato e curvato. La particolare curvatura del vetro e uno speciale processo di tempera conferiscono al cristallo una straordinaria resistenza ai carichi. È disponibile anche una versione in cristallo argentato dall'aspetto molto prezioso.



Dimensioni:

BEB01 L 200 P 49 H 41

BES02 L 40 P 49 H 40



Bench and stool with an aspect of natural simplicity, made from shaped and curved 12 mm thick transparent extralight glass. The particular glass curvature and a special tempering process endow the glass with an extraordinary load resistance. It is also available a version in silver glass with a precious appearance.

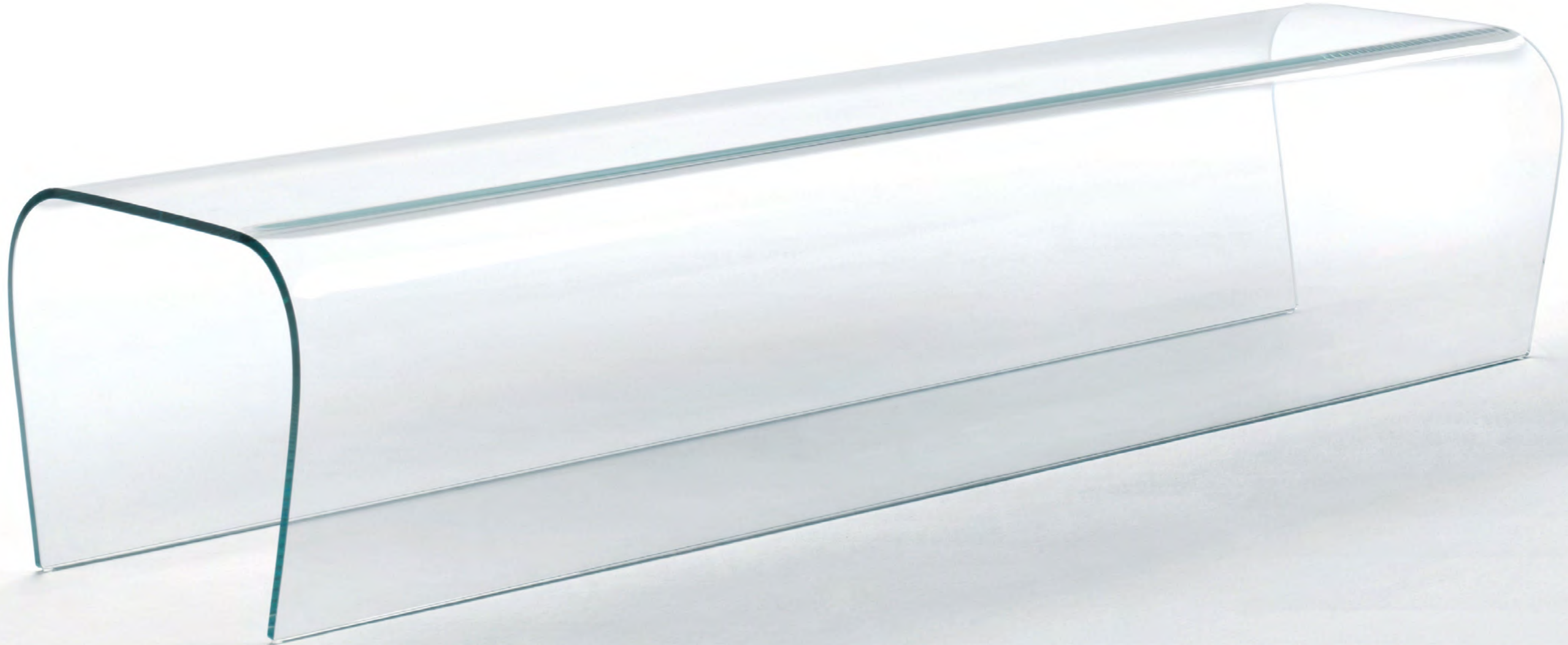



■ ← INDEX





Collezione di divani componibili e poltrone in cristallo trasparente extralight 15 mm sagomato, temperato ed incollato a UV. La struttura in cristallo contiene soffici cuscini sfoderabili, disponibili in vari tessuti o ecopelle di diversi colori. L'imbottitura è disponibile in Dacron o in un nuovo soffice fiocco anallergico, cruelty-free ed eco compatibile, ottenuto riciclando plastiche raccolte dagli oceani. Componendo moduli laterali (dx e sx) con moduli centrali e angolari, è possibile dar vita a svariate configurazioni.

Finiture: campionari tessuti

Dimensioni:

CRP01 L 99 P 90 H 66
seduta / seat 44
CRP02 L 115 P 90 H 66
seduta / seat 44
CRP03 L 115 P 90 H 66
seduta / seat 44
CRP04 L 89 P 90 H 66
seduta / seat 44

CRP05 L 319 P 90 H 66
seduta / seat 44
CRP06 L 230 P 90 H 66
seduta / seat 44
CRP07 L 86 P 60 H 44
seduta / seat 44
CRP08 L 90 P 90 H 66
seduta / seat 44

Collection of sectional sofas and armchair in shaped 15 mm extra clear glass tempered and UV glued. The glass structure contains soft cushions with removable covers, available in different fabrics and eco-leather in many different colors. The filling is made in Dacron or in a new soft material obtained from the recycled plastic from the oceans, the material is allergy free, cruelty-free and eco compatible (sustainable). Putting together lateral modules (left and right) and central modules it's possible to create many different configurations.

Finishes: fabric samples











Dimensioni:

CRY01 ø 32

H 48



Stool or side table in UV bonded 24 mm tempered transparent glass. Following sophisticated and complex manufacturing processes, an object entirely in glass has been created with high load resistance and masterfully resolved details. Discreet mirror-polished stainless-steel feet finish and embellish the object.

Sgabello-piccolo tavolino in cristallo trasparente 24 mm temperato, incollato a UV. Grazie a sofisticate e complesse lavorazioni è stato realizzato un oggetto completamente in cristallo, estremamente resistente ai carichi e dai dettagli magistralmente risolti. Dei discreti piedini in acciaio inox lucidato a specchio rifiniscono ed impreziosiscono l'oggetto.







■ ← INDEX



Collezione composta da panca, divanetto, scrittoi e piccola libreria in cristallo extralight stratificato e termosaldato, con elementi in massello di frassino naturale o rovere moro fissati alle estremità delle spalle portanti. È disponibile una versione monocromatica in vetro trasparente nelle possibili seguenti finiture: extralight, grigio chiaro, grigio scuro, lilla o rosso Siena. Vi è inoltre una seconda versione bicromatica, sempre in vetro trasparente, declinabile in due possibili combinazioni:

- a) schienale rosso Siena, spalle e piani/seduta grigio chiaro.
- b) schienale lilla, spalle e piani/seduta extralight.

La panca è disponibile solo nella variante monocromatica. Le sedute sono fornite con un cuscino di feltro nero o grigio mélange da 12 mm di spessore. Sui piani degli scrittoi è posizionato un pannello in legno di frassino naturale o rovere moro. La libreria e gli scrittoi sono disponibili con foro passacavi.



Dimensioni:

DIA01 L 141 P 53 H 74
DIA02 L 141 P 53 H 114
DIA03 L 101 P 53 H 161
DIA04 L 101 P 53 H 124

DIA05 L 141 P 44 H 84
DIA06 L 130 P 43
feltro per sedute / upholstery for seats
DIA07 L 70 P 51
sovrappiano per scrittoi / overtop for desks

Collection comprising a bench, sofa, desks and small bookcase in transparent extralight, laminated and thermo-welded glass with elements of solid natural ash or dark brown oak at the outer edges of the supporting sides. A monochromatic version is available in transparent glass in the following finishes: extralight, clear grey, dark grey, lilac or sienna red. There is also a second version in two colours, still in transparent glass, available in two different combinations:

- a) Siena red back, clear grey sides and top/seat.
- b) lilac back, extralight sides and top/seat.

The bench is available only in the monochromatic version. The seats are supplied with a cushion in black or mélange grey 12 mm thick felt. A panel in natural ash wood or in dark brown oak lays on the desks tops. The bookcase and the desks are available with cable outlet.







INDEX ←





Collezione di tavoli bassi-panche, realizzati incollando insieme tre lastre di cristallo fumè in modo tale da assumere l'aspetto di una putrella. Il pianoseduta e la base sono in cristallo temperato 12 mm, mentre il supporto verticale è in cristallo stratificato. Nonostante la giunzione dei cristalli sia molto esigua e lineare, l'impiego di incollaggi strutturali ad alta resistenza permette di utilizzare questi elementi come sedute. La collezione è completata da cuscini sfoderabili in tessuto di colore nero.

Dimensioni:

IBE02 L 60 P 60 H 29
IBE03 L 200 P 60 H 29
IBE04 L 140 P 60 H 29

IBE06 L 60 P 60
cuscino/cushion
IBE07 L 140 P 60
cuscino/cushion

Collections of low tables-benches, obtained by gluing together three slabs of smoked glass so that they look like a joist. The top-seat and the base are in 12 mm thick tempered glass, whereas the vertical support is in laminated glass. Although the glass junction is very little and linear, the adoption of high resistant structural gluing enables the use of these elements as seats. The collection is completed by removable cushions in a black colour fabric.







■ ← INDEX





Sedia realizzata interamente in cristallo incollato, disponibile nelle finiture trasparente extralight, cristalli trasparenti colorati. La versione trasparente extralight è in cristallo 15 mm temperato, mentre quella trasparente colorata è in cristallo stratificato 8+8 mm.

Finiture: cristallo trasparente extralight / cristalli trasparenti colorati

Dimensioni: MEB01 L 42 P 44 H 104

Chair entirely realized in glued glass, available in the finishes transparent extralight, transparent coloured glasses. The transparent extralight version is in tempered 15 mm thick glass, whilst the transparent coloured version is in laminated 8+8 mm thick glass.

Finishes: transparent extralight glass / transparent coloured glass





INDEX ←





Poltroncina in cristallo trasparente extralight in 19 mm temperato e termosaldato. I cristalli sono rifiniti con speciali bisellature, che riflettono e rifrangono la luce, conferendo all'oggetto un aspetto di rara preziosità. All'estrema leggerezza formale della seduta, fa riscontro una notevole resistenza ai carichi.

Dimensioni: **PRC01** L 57 P 57 H 70

Small armchair in transparent extralight 19 mm thick tempered and thermowelded glass. The glass is embellished with special bevelling which reflects and refracts the light, lending the object a rare preciousness. Despite its extreme lightness of form, the seat has considerable weight bearing capacity.





INDEX ←





Collezione di divani di grande leggerezza e pulizia formale, con struttura in cristallo trasparente extralight 19 mm sagomato, temperato e assemblato con incollaggi UV. La struttura è rivestita da soffici cuscini, sfoderabili e disponibili in vari tessuti o ecopelle di diversi colori. L'imbottitura, soffice come se fosse in piuma d'oca, è realizzata in materiale anallergico, cruelty free ed eco-compatibile, ottenuto riciclando plastiche raccolte dagli oceani. Sono disponibili due versioni: una con tavolino laterale integrato nella seduta (a destra o a sinistra), l'altra a doppia seduta contrapposta. I modelli TET01 e TET02 vengono forniti col cuscino seduta e due cuscini per schienale, mentre il modello TET03 col cuscino seduta e quattro cuscini per schienale. A richiesta vengono forniti cuscini per schienale TET04 aggiuntivi.

Finiture: campionari tessuti

Dimensioni:

TET01 L 200 P 77 H 40 seduta 63 schienale <i>Con tavolino a dx / with table on dx</i>	TET03 L 180 P 77 H 40 seduta 63 schienale
TET02 L 200 P 77 H 40 seduta 63 schienale <i>Con tavolino a sx / with table on sx</i>	TET04 L 50 H 50 <i>Cuscino per schienale / back cushion</i>

Collection of sofas characterized by formal clean and light design, with structure in 19 mm thick transparent extralight glass, shaped, tempered and UV-bonded. The structure is covered with soft removable cushions available in different fabrics or faux - eco-leather in different colors. The padding, as soft as goose down, is made of hypoallergenic, cruelty free and eco-compatible material, obtained by recycling plastics collected from the oceans. Two versions are available: one with a side table integrated into the seat (on the right or left), the other with a twin facing seat. The TET01 and TET02 models are supplied with a seat cushion and two back cushions, while the TET03 model with a seat cushion and four back cushions. Additional TET04 back cushions are supplied on request.

Finishes: fabric samples







INDEX ←



Panca in cristallo acidato extralight da 30 mm di spessore (15 +15 mm), molato filo opaco.



Dimensioni:

PTR01 L 120 P 30 H 42

PTR02 L 140 P 40 H 42



Bench in laminated extralight acid-etched glass 30 mm thick (15 +15 mm) with matt ground edge.

CONTENITORI /
STORAGE UNITS
LIBRERIE /
BOOKCASES
VETRINE /
DISPLAY CASES



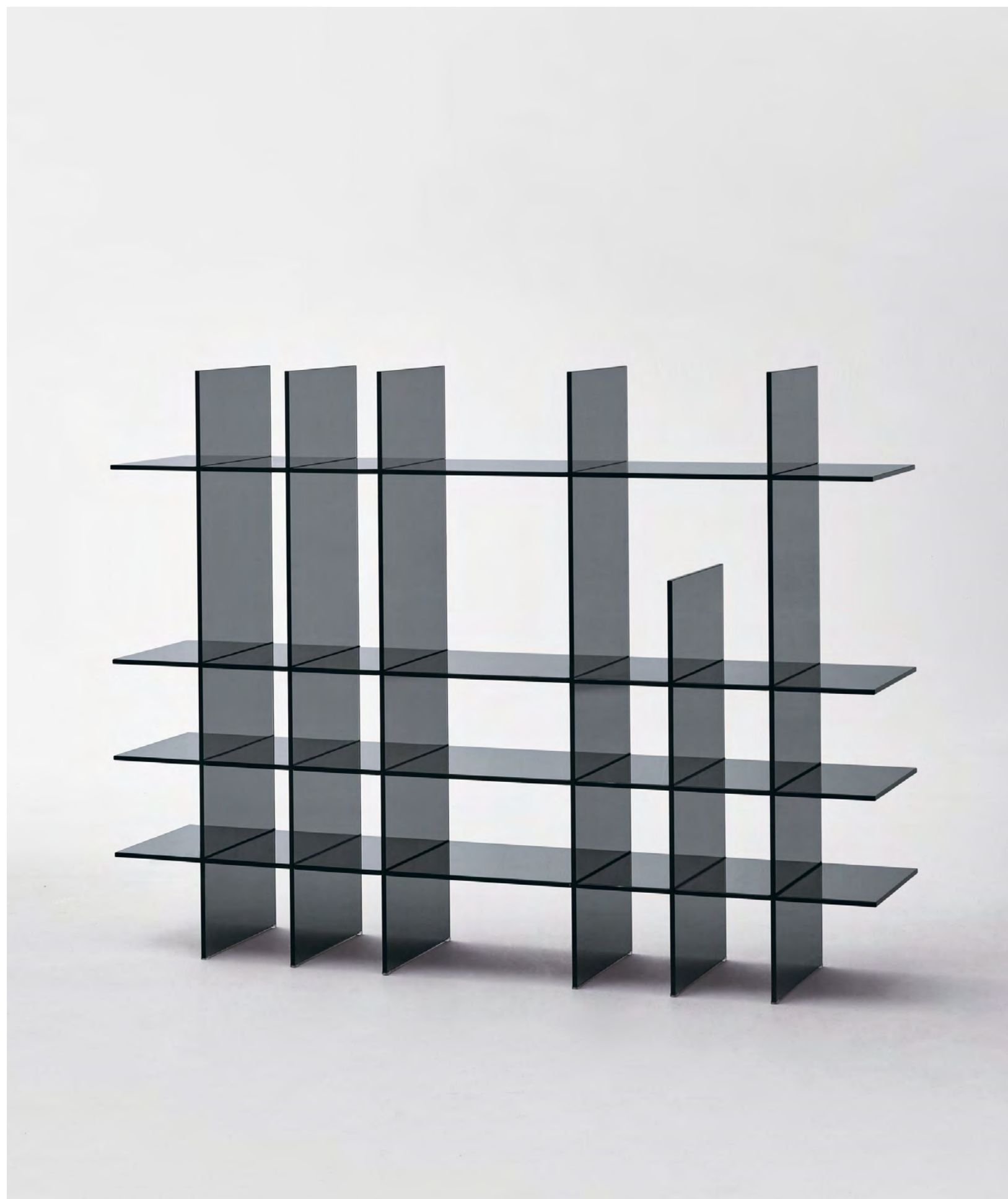

Libreria di grande pulizia formale, realizzata in cristallo fumé o extrachiaro 10 mm termosaldato, senza l'ausilio di alcun giunto o elemento strutturale estraneo. Un unico elemento modulare può essere liberamente ruotato e accostato, mantenendo gli allineamenti dei ripiani, in modo da dar forma a varie numerose configurazioni.

Dimensioni: **AMI01** L 120 P 35 H 160

Bookcase of great formal cleanliness, made from thermo-welded 10 mm thick smoked or extralight glass, without any joint or extraneous structural element. A single modular element can be freely rotated and placed side by side, keeping the shelf alignment, allowing various and numerous configurations.





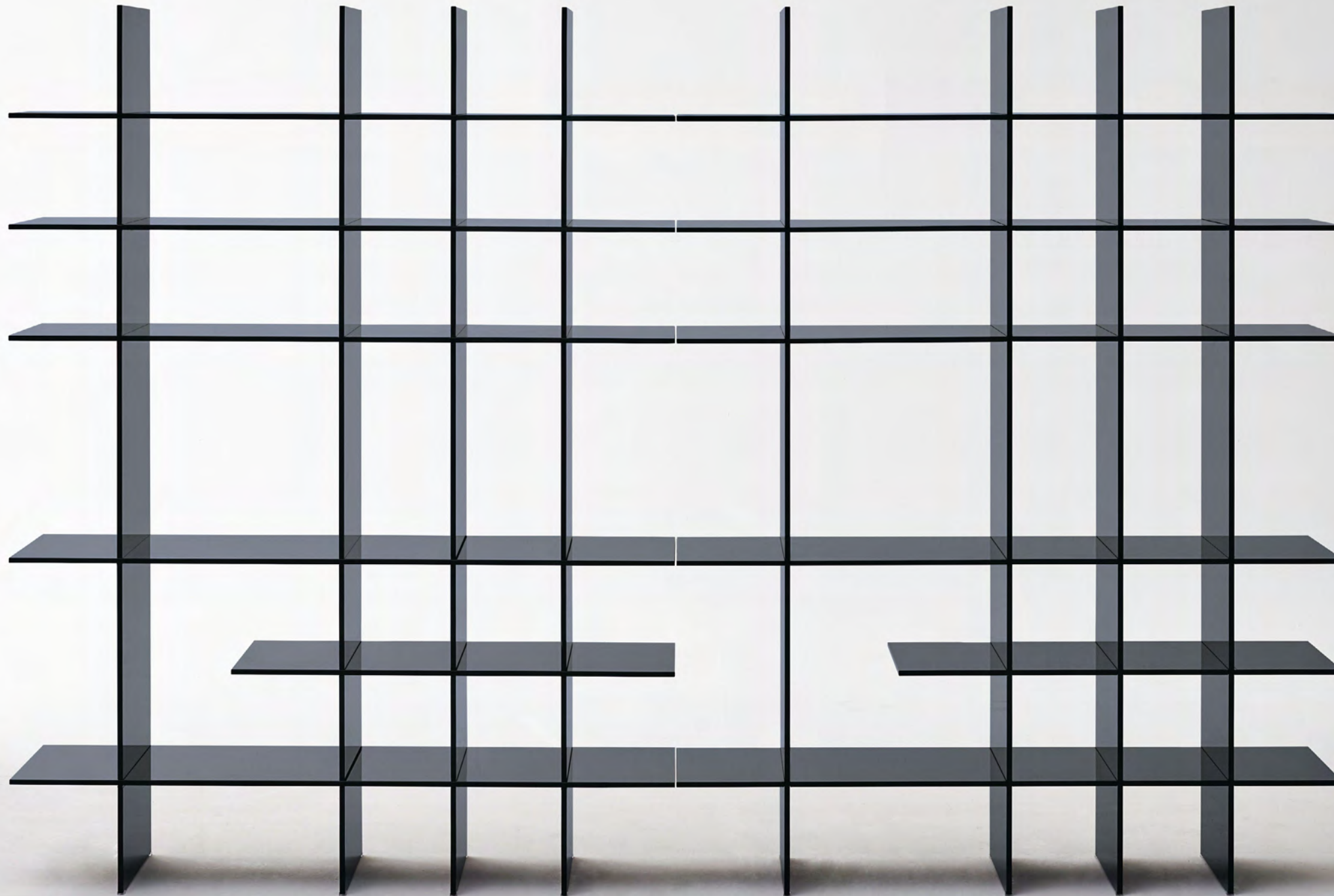



■ ← INDEX



Collezione di tavolini - espositori e vetrine con fianchi e top in cristallo trasparente extralight 8 mm. I fianchi sono curvati in modo da combaciare con la sagomatura del top, a cui sono incollati. Le vetrine, con ferramenta in alluminio anodizzato nero, sono provviste di un ripiano. Le basi sono in massello di frassino laccato nero poro aperto e, solo nei tavolini, con uno specchio incassato a filo. All'interno delle vetrine (COR03 - COR06) si accede per mezzo di ante, mentre nei tavolini grazie allo scorrimento di due frontalini.



Dimensioni:

COR01 L 130 P 70 H 34

COR03 L 120 P 40 H 85

COR02 L 110 P 110 H 34

COR06 L 120 P 40 H 120



Collection of low tables and display units with sides and top in transparent extralight 8 mm glass. The sides are curved to fit the shape of the top, to which they are attached. The display units are supplied with hardware in black anodized aluminium and a shelf. The bases are in solid open pore black lacquered ash and, for the low tables only, they have a flush recessed mirror. The display units (COR03 - COR06) have doors, while the low tables have two sliding front parts.





← INDEX





Mobili in cristallo stampato a quadretti, 8 mm, temperato e incollato a 45°, con base argentata. Le antine scorrevoli sono inserite in guide di plexiglass trasparente, mentre le esili gambe sono in metallo cromato lucido. Forniti con ripiani in cristallo extralight 8 mm temperato.

Dimensioni: **COM01** L 100 P 50 H 120 **COM02** L 180 P 50 H 96

Storage furniture in checked printed 8 mm glass, tempered and glued 45°, with silvered base. The sliding doors run in transparent plexiglass tracks, whilst the slender legs are in glossy chromium-plated metal. Supplied with 8 mm thick tempered extralight glass shelves.



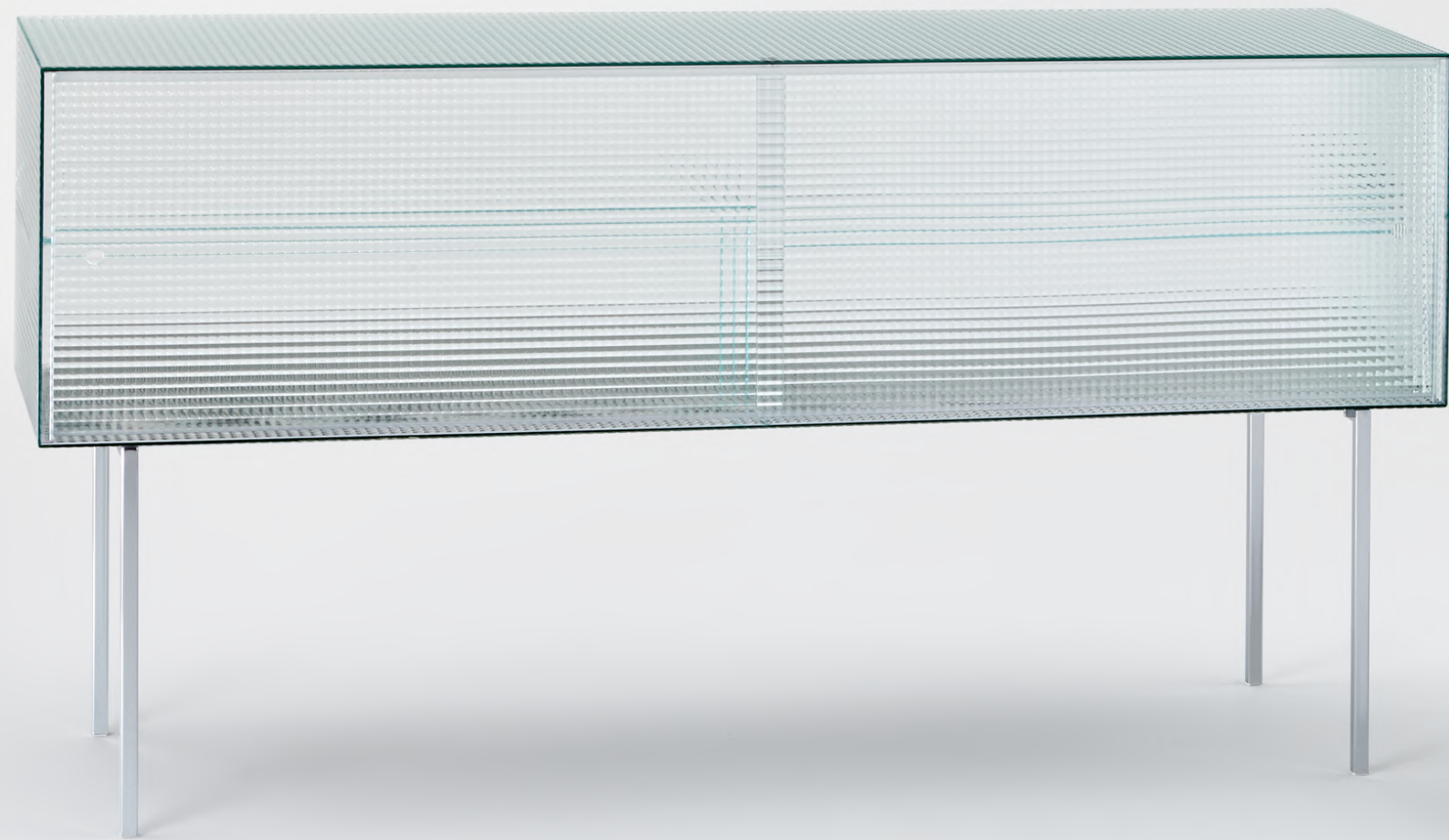



INDEX ←





Collezione di tavoli bassi e libreria in cristallo trasparente extralight stratificato e termosaldato. I ripiani della libreria e gli elementi verticali dei tavolini sono in cristallo trasparente colorato nei toni del grigio o dell'azzurro. Passando da un elemento all'altro, la distanza tra gli stessi diminuisce gradualmente, mentre l'intensità del colore diventa sempre più carica. Questo effetto cromatico, associato alle basi in specchio, conferisce ai pezzi grande profondità e un gioco di magici riflessi.



Dimensioni:

DEE01 L 75 P 75 H 37
tavolino / low table
DEE02 L 125 P 48 H 37
tavolino / low table

DEE03 L 75 P 35 H 151
libreria / bookcase



Collection of low tables and bookcase in laminated and thermo-welded transparent extralight glass. The shelves of the bookcase and the vertical elements of the low tables are in coloured transparent glass available in grey or blue tone. Moving from one element to the next, the distance between them gradually decreases, whilst the intensity of colour increases. This chromatic effect, associated with the mirror bases, bestows great depth to the pieces and a play of magical reflections.



INDEX ←





Serie di mobili contenitori a giorno in cristallo stratificato 5+5 mm, molato filo lucido e termosaldato. Disponibili in cristallo trasparente extralight o trasparente colorato.

Finiture: cristallo trasparente extralight / cristalli trasparenti colorati

Dimensioni:	DJMH01	L 30	P 45	H 45,5	DJMH04	L 60	P 45	H 195,5
	DJMH02	L 60	P 45	H 45,5	DJMH05	L 120	P 45	H 107,5
	DJMH03	L 30	P 45	H 195,5	DJMH07	L 120	P 45	H 54,5

Series of open storage furniture in laminated 5 + 5 mm thick shiny ground and thermo-welded glass. Available in transparent extralight glass or transparent coloured glass.

Finishes: transparent extralight glass / transparent coloured glass

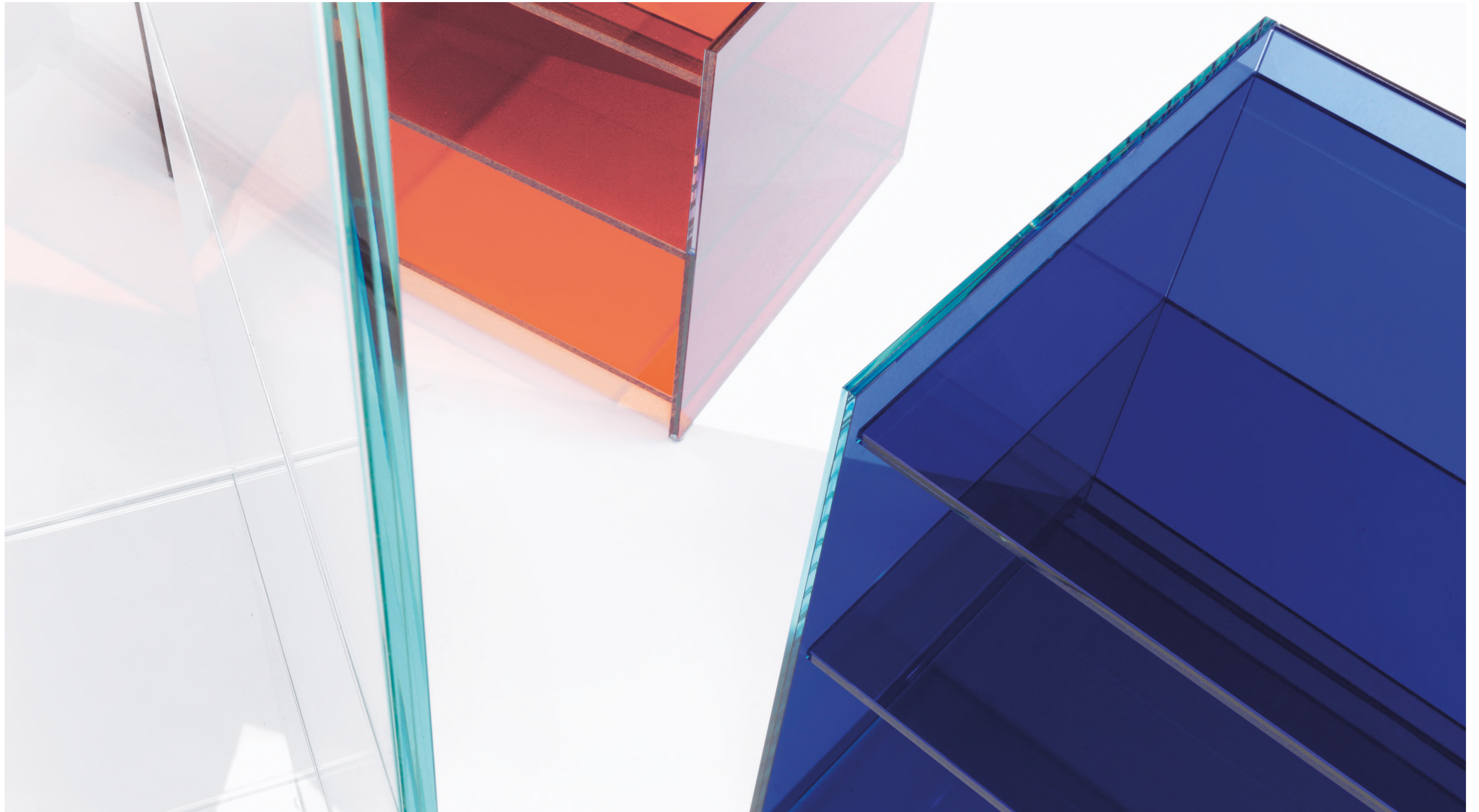



INDEX ←





Collezione di mobili contenitori con ante scorrevoli, realizzati in cristallo acidato extrachiaro temperato, incollato a UV. Una scatola in legno di rovere nero con funzione di vano porta oggetti è sezionata e fissata al mobile in modo che una parte rimanga al suo interno e l'altra in appoggio sul top. L'effetto ottenuto è quello di un volume solido che sembra galleggiare in un liquido, emergendo parzialmente. Le ante scorrono all'interno di profili in alluminio anodizzato naturale. Il cristallo della base, argentato, diffonde luminosità all'interno del mobile.

**Dimensioni:**

DRI01 L 190 P 35 H 41
DRI02 L 80 P 35 H 131

DRI03 L 80 P 35 H 81



Collection of storage furniture with sliding doors made from tempered, UV bonded, acid-etched extra-clear glass. A black oak wooden box serving as a storage unit is partitioned and fixed to the furniture, so that one part remains inside and the other rests on the top. The effect obtained is that of a solid mass that seems to float in a liquid, partially emerging. The doors slide within natural anodized aluminum profiles. The glass base is silvered and radiates brightness within the furniture.







INDEX ←



Serie di cassetiere in cristallo di varie tipologie e misure con sistema di apertura a pressione. Le spalle e lo schienale, realizzate in cristallo trasparente extralight 12 mm incollato a 45°, sostengono cassetti in wengé rivestiti esternamente in cristallo temperato, laccato lucido in diversi colori. Il fondo dei cassetti è in cristallo nella medesima finitura dell'esterno.

Finiture: cristalli laccati lucidi



Dimensioni:

FLO02 L 63 P 45,5 H 50
FLO04 L 63 P 45,5 H 113
FLO05 L 122 P 45,5 H 90

FLO06 L 100 P 45,5 H 79
FLO07 L 45,5 P 45,5 H 50
FLO08 L 180 P 45,5 H 90



Series of glass chest of drawers of different types and sizes with a pressure opening system. The sides and the back, realized in 12 mm thick glued 45° transparent extralight glass, support drawers in wengé covered on the outside with tempered glass, glossy lacquered in different colours. The bottom of the drawers is in glass in the same finish as the outside.

Finishes: glossy lacquered glass





← INDEX





Libreria dall'eccezionale pulizia formale e dalle proporzioni auree, realizzata interamente in cristallo trasparente 12 mm termosaldato, senza l'ausilio di alcun elemento estraneo. Prodotto storico ed iconico del design internazionale, disegnato dal grande maestro Shiro Kuramata nel 1976.

Dimensioni: **KUS** L 165 P 35 H 196

Bookcase characterised by the extraordinary formal cleanness and the golden ratio, entirely realized in thermo-welded 12 mm thick transparent glass, without the aid of any foreign element. Historical and iconic product of the international design, designed in 1976 by the great master Shiro Kuramata.



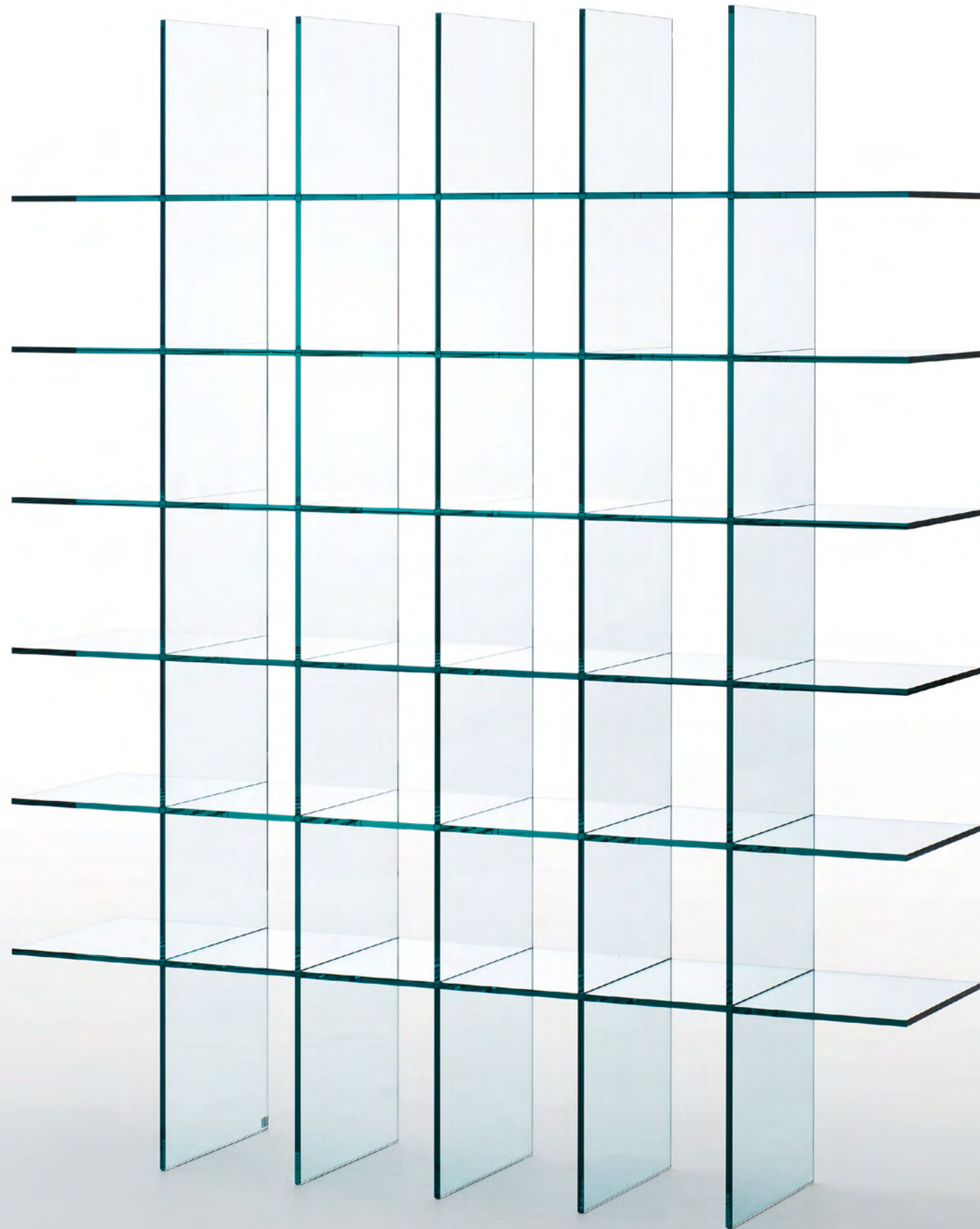



INDEX ←





Serie di vetrine pensili con serratura, in cristallo trasparente extralight 6 mm, temperato e incollato a 45°, nelle varianti diritte (a forma di parallelepipedo) e oblique (a forma di prisma irregolare), disponibili con schienale a specchio o luminoso con impianto a led. Gli oggetti contenuti sembrano magicamente sospesi nell'aria. Speciali cerniere, fissate alla parete tramite un telaio, permettono ai volumi in cristallo di ruotare, in modo da potere accedere al loro interno. Le vetrine sostengono un peso massimo di 15 kg.

Dimensioni:

HEI01 L 47 P 30 H 130
diritta / straight
HEI01R L 47 P 30 H 130
diritta con ripiano / straight with shelf
HEI02 L 41 P 30 H 60
diritta / straight
HEI03 L 41 P 40 H 40
diritta / straight

HEI04 L 59 P 42 H 40
obliqua / oblique
HEI05 L 52 P 33 H 130
obliqua / oblique
HEI05RL L 52 P 33 H 130
obliqua con ripiano / oblique with shelf
HEI06 L 52 P 33 H 60
obliqua / oblique



Series of aerial hanging display cases with lock, in transparent extralight 6 mm thick tempered and glued at 45°, available in straight (parallelepiped shape) and oblique (irregular prism shape) versions and with a mirrored back or with illuminated Led system. Objects within give the illusion of being magically suspended midair. Special hinges fixed to the wall by means of a frame allow the glass cases to revolve enabling access to the inside. The display cases support a maximum weight of 15 kg.





INDEX ←



Librerie in cristallo extrachiario opaco bianco, stratificato 8+8 mm e incollato. I ripiani sono parzialmente schermati da ante scorrevoli appese al top, realizzate in cristallo trasparente con speciali colorazioni che, sovrapponendosi, creano cromie in continuo mutamento. È disponibile una versione con ante nelle tonalità calde (arancio-rosso-marrone) e una nelle tonalità fredde (azzurro-grigio-viola). Il top e le ante sono smontabili.

Dimensioni:

LAY01 L 160 P 50 H 108

LAY02 L 200 P 50 H 81

Bookshelves in white matt extralight lacquered glass, 8+8 mm thick laminated and glued. The shelves are partially obscured by sliding doors suspended from the top, made of transparent glass with special colors which, by overlapping, create constantly changing chromatic imagery. Two versions are available with doors in warm tones (orange-red-brown) and in cold tones (blue-grey-violet). The top and the doors can be dismantled.

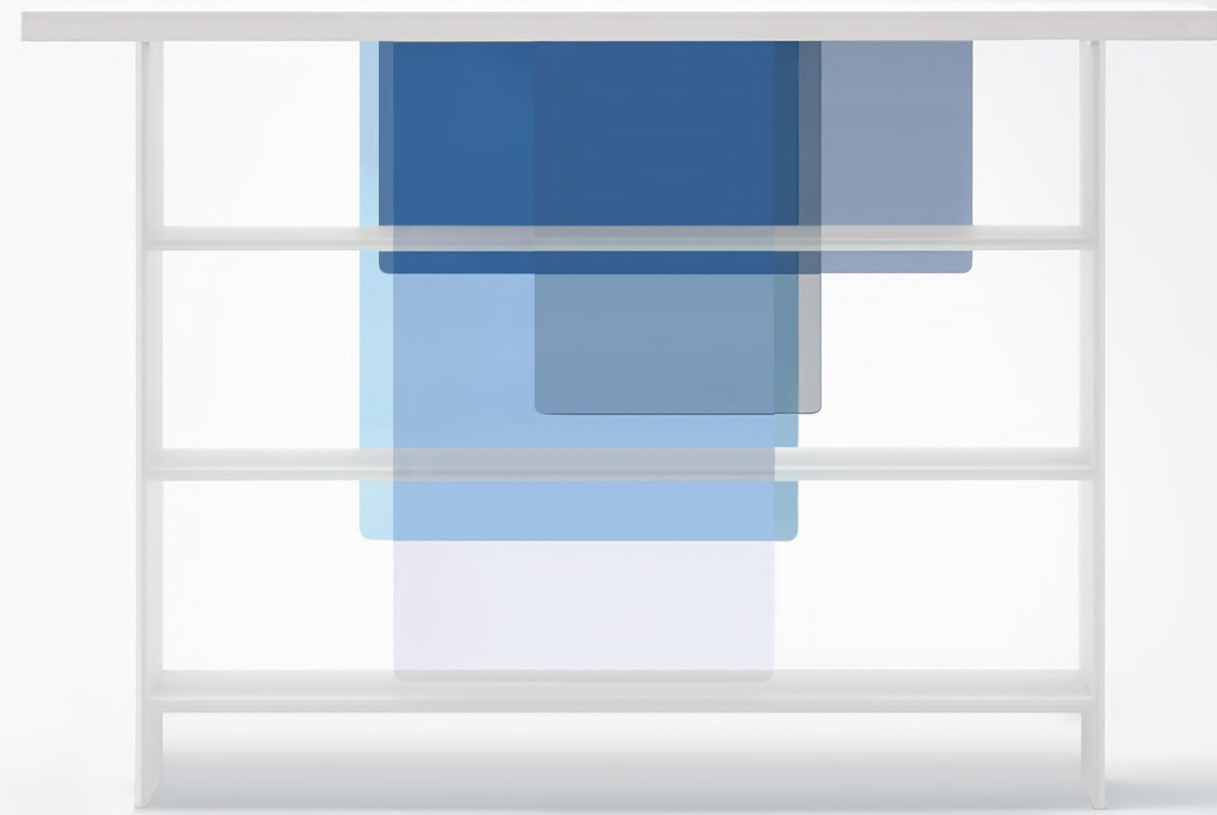



■ ← INDEX





Serie di mobili contenitori in cristallo temperato, laccato lucido o opaco o gres (eccetto MGB05) incollato a 45°, con interno in legno nobilitato colore antracite opaco e ripiani in cristallo trasparente extralight 10 mm temperato. I vani, chiusi da ante con sistema di apertura push-pull, sono rivestiti in specchio (no spalle). I codici MGB02-04-08 sono sostenuti da sottili gambe in metallo cromato lucido o da due lastre di cristallo extralight temperato. A richiesta (ad eccezione di MGB05) sono forniti con fori passacavi nelle basi, a scelta nel vano di dx, di sx o in entrambi.

Finiture: cristalli laccati lucidi / cristalli laccati opachi / gres

Dimensioni:

MGB01 L 242 P 45 H 54
con 4 ante / with 4 doors
MGB02 L 242 P 45 H 80
con 4 ante - con gambe / with 4 doors - with legs
MGB03 L 120 P 45 H 54
con 2 ante / with 2 doors
MGB04 L 120 P 45 H 80
con 2 ante - con gambe / with 2 doors - with legs

MGB05 L 120 P 45 H 107
con 2 ante no gres / with 2 doors no stoneware
MGB07 L 180 P 45 H 54
con 3 ante / with 3 doors
MGB08 L 180 P 45 H 80
con 3 ante - con gambe / with 3 doors - with legs

Series of storage furniture in tempered glossy or opaque lacquered glass or stoneware (except for MGB05) glued 45°. The interior is in laminated opaque charcoal coloured wood and shelves in 10 mm thick transparent extralight glass. The compartments are closed by doors with push-pull opening system and are covered with mirror (no sides). The codes MGB02-04-08 are supported by a base with thin legs in glossy chromed metal or by two slabs of tempered extralight glass. On demand, provided with cable outlets in the bases (except for MGB05), that can be available in the right or left compartment or in both of them.

Finishes: glossy lacquered glass / opaque lacquered glass / stoneware



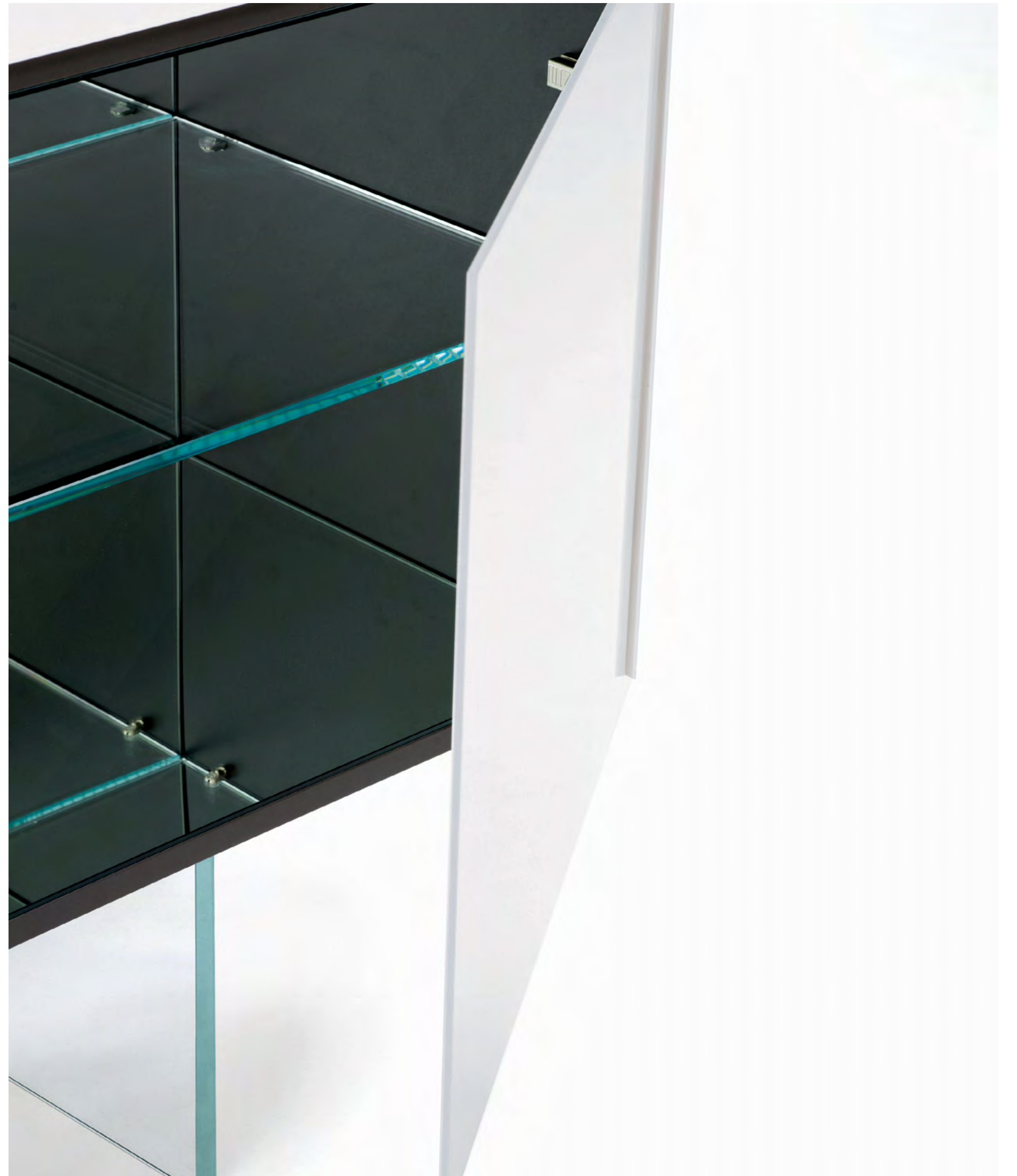
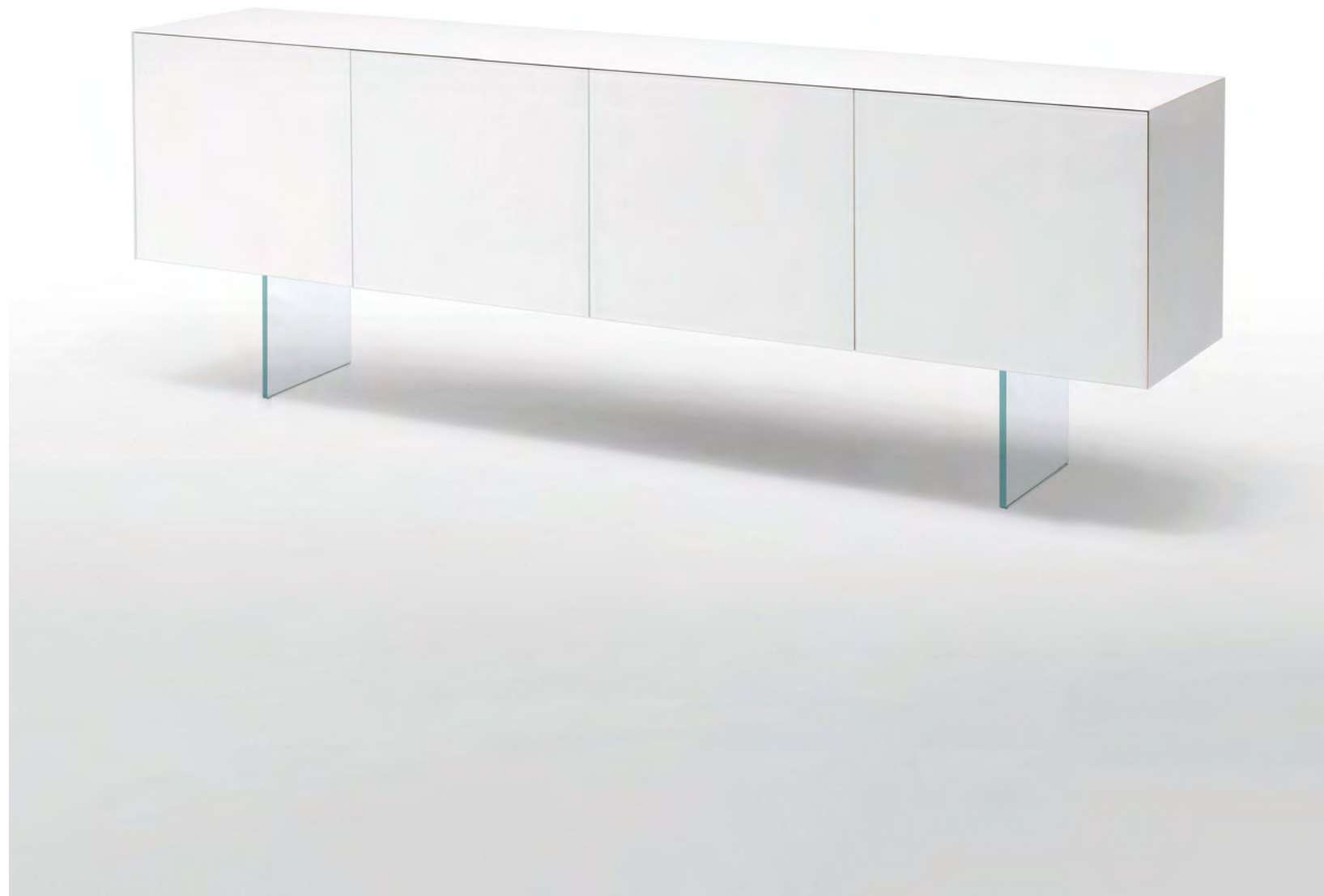





INDEX ←





Serie di cassettiere con struttura in cristallo stratificato, trasparente colorato, incollato a UV e una base e cassetti in massello di frassino, in un naturale colore moro, conferito da un trattamento termico. Listelli in cristallo extralight, incollati sui fianchi dei mobili, fungono da guide "invisibili" su cui scorrono i cassetti - lasciati completamente a vista - grazie a scanalature ribassate sui fianchi. Ne risultano oggetti con una raffinata soluzione tecnica, dall'elevato valore estetico e formale. Disponibili in cristallo monocromatico o nella versione con schienale in un colore differente. Sotto alla base sono posizionate delle ruote, che ne consentono un facile spostamento.

Finiture: cristalli trasparenti colorati

Dimensioni:

MAN01 6 cassetti/drawers	L 60	P 50	H 154	MAN02D 9 cassetti/drawers	L 110	P 50	H 189
MAN02A 3 cassetti/drawers	L 110	P 50	H 189	MAN02E 9 cassetti/drawers	L 110	P 50	H 189
MAN02B 3 cassetti/drawers	L 110	P 50	H 189	MAN02F 12 cassetti/drawers	L 110	P 50	H 189
MAN02C 6 cassetti/drawers	L 110	P 50	H 189	MAN03 6 cassetti/drawers	L 150	P 50	H 118

Series of glass chest of drawers with structure in transparent colored laminated glass, UV-bonded with base and drawers in naturally darkened solid ash created with a heat treatment. Extralight glass strips, glued to the sides of the furniture, act as "invisible" runners for the drawers - left completely visible - thanks to lowered grooves on the sides. The results are objects with a refined technical solution, a high aesthetic and formal value. Available in monochromatic glass or a version with the back in a different color. Under the base there are wheels allowing easy movement.

Finishes: transparent colored glass









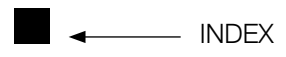

Serie di mobili contenitori a giorno in cristallo stratificato 6+4 mm, molato filo lucido e termosaldato a 45°. La superficie esterna presenta una speciale finitura a specchio, mentre la superficie interna è in specchio opacizzato, che riflette le immagini in maniera sfuocata ed indefinita.



Obliquo



Dimensioni:

OBL01 L 90 P 40 H 189
OBL02 L 90 P 40 H 189
OBL03 L 90 P 40 H 189
OBL04 L 240 P 40 H 82
OBL05 L 120 P 40 H 82

OBL06 L 120 P 40 H 37
OBL07 L 120 P 40 H 37
OBL08 L 120 P 40 H 37
OBL09 L 120 P 40 H 37



Series of open storage units in 6+4 mm laminated glass, with shiny polished ground edge and heat-sealed at 45°. The external surface has a special mirrored finish, while the internal surface is in opaque mirror, which reflects the images in a blurry and undefined way.







INDEX





Libreria a totem con schienale verticale in specchio extrachiaro bifacciale, stratificato 12+12 mm. Le scaffalature, saldate allo schienale, sono realizzate in cristallo extrachiaro 10 mm, incollato a 45° e in cristallo curvato a 180°. Lo schienale in specchio crea un gioco di riflessi, che conferiscono un effetto di profondità e continuità. La base, fissata in maniera removibile, è rivestita in specchio extrachiaro 10 mm.

Dimensioni: OLI01 L 71 P 38 H 171



Freestanding totem bookcase with vertical back panel in double-sided extra clear mirror, laminated 12+12 mm. The shelves, bonded to the back panel, are made from 10 mm extra-clear glass, glued at 45°, and in 180° curved glass. The mirror back panel creates a game of reflections, conveying an illusion of depth and continuity. The removeable base is covered in 10 mm extra-clear mirror.





INDEX ←





Mobili in uno speciale cristallo specchiato dalle forme curve e morbide. La struttura è in cristallo stratificato 6+6 mm completamente specchiante, sia all'interno sia all'esterno. Le ante sono in cristallo specchiante bifacciale 6 mm curvato e temperato, dai riflessi distorti e indefiniti, che rendono il materiale inafferrabile e dall'apparenza quasi liquida. Le ante hanno chiusura blumotion ammortizzata e sono apribili per mezzo di maniglie cilindriche in cristallo.

**Dimensioni:****OLT01** L 96 P 47 H 95**OLT02** L 44 P 26 H 55

Storage units in a special mirrored glass with soft curved shapes. The structure is in 6+6 mm laminated glass fully mirrored, both inside and outside. The doors are in 6 mm curved and tempered double-sided mirrored glass, characterized by distorted and undefined reflections, which allow the material to be elusive and optically fluid. The doors have a blue-motion soft closure and are opened with cylindrical glass handles.







INDEX ←





Armadio in cristallo trasparente extralight 12 mm, temperato e termosaldato, con speciali e preziose bisellature che riflettono e rifrangono la luce. La base è in specchio extralight mentre la barra porta abiti e la ferramenta sono in acciaio lucido. Sulla base è posizionata una panchetta nello stesso materiale e con le stesse lavorazioni dell'armadio. Le ante, in cristallo extralight 8 mm temperato, hanno chiusura blumotion ammortizzata e sono apribili per mezzo di maniglie di cristallo. È un espositore che magnifica e valorizza enormemente gli abiti e gli oggetti in esso contenuti.

Dimensioni:

PRW01 L 100 P 60 H 195

PRW02 L 86 P 44 H 18

Wardrobe in transparent extralight 12 mm tempered and thermo-welded glass, with precision bevelling which reflects and refracts the light. The base is in extralight mirror, the coat hanger bar and the hardware are in polished steel. On the base is a small bench in the same material and with the same features of the storage unit. The doors, in transparent extralight 8 mm tempered glass, have a blue-motion soft closure and are opened with glass handles. Clothing and objects within are visually enhanced and highlighted by this display unit.







INDEX ←





Librerie composte da scatole di diverse misure, realizzate in cristallo trasparente extralight 10 mm temperato, incollato a 45°, sovrapposte in maniera sfalsata ed irregolare. Disponibili con schienale in cristallo extralight, fumé, bronzo o nelle finiture dei "Cristalli trasparenti colorati". Le scatole appoggiano su una base in legno di rovere laccato nero poro aperto e sono fissate tra di loro per mezzo di minimali giunti in metallo cromato. Ogni composizione è disponibile in versione fruibile da un lato o da due lati.

Finiture: cristallo trasparente extralight / cristallo fumé / cristallo bronzo / cristalli trasparenti colorati

Dimensioni:	QUA01	L 330	P 40	H 164	QUA09	L 190	P 40	H 164
	QUA02	L 330	P 40	H 124	QUA10	L 190	P 40	H 124
	QUA03	L 330	P 40	H 84	QUA11	L 190	P 40	H 84
	QUA04	L 330	P 40	H 84	QUA12	L 190	P 40	H 84
	QUA05	L 270	P 40	H 164	QUA13	L 150	P 40	H 164
	QUA06	L 270	P 40	H 124	QUA14	L 150	P 40	H 124
	QUA07	L 270	P 40	H 84	QUA15	L 150	P 40	H 84
	QUA08	L 270	P 40	H 84	QUA16	L 150	P 40	H 44

Bookcases made of boxes of different sizes in transparent 10 mm extralight tempered glass, glued at 45° and deliberately overlapped in a misaligned and irregular way. Available with back in transparent extralight, smoked, bronze glass or in "transparent coloured glass". The boxes lay on a flamed oak base black lacquered open pore and they are fixed to each other by means of minimal metal joints in black anodized finish. Each composition is available in a version either usable from one or both sides.

Finishes: transparent extralight glass / smoked glass / bronze glass / transparent coloured glass



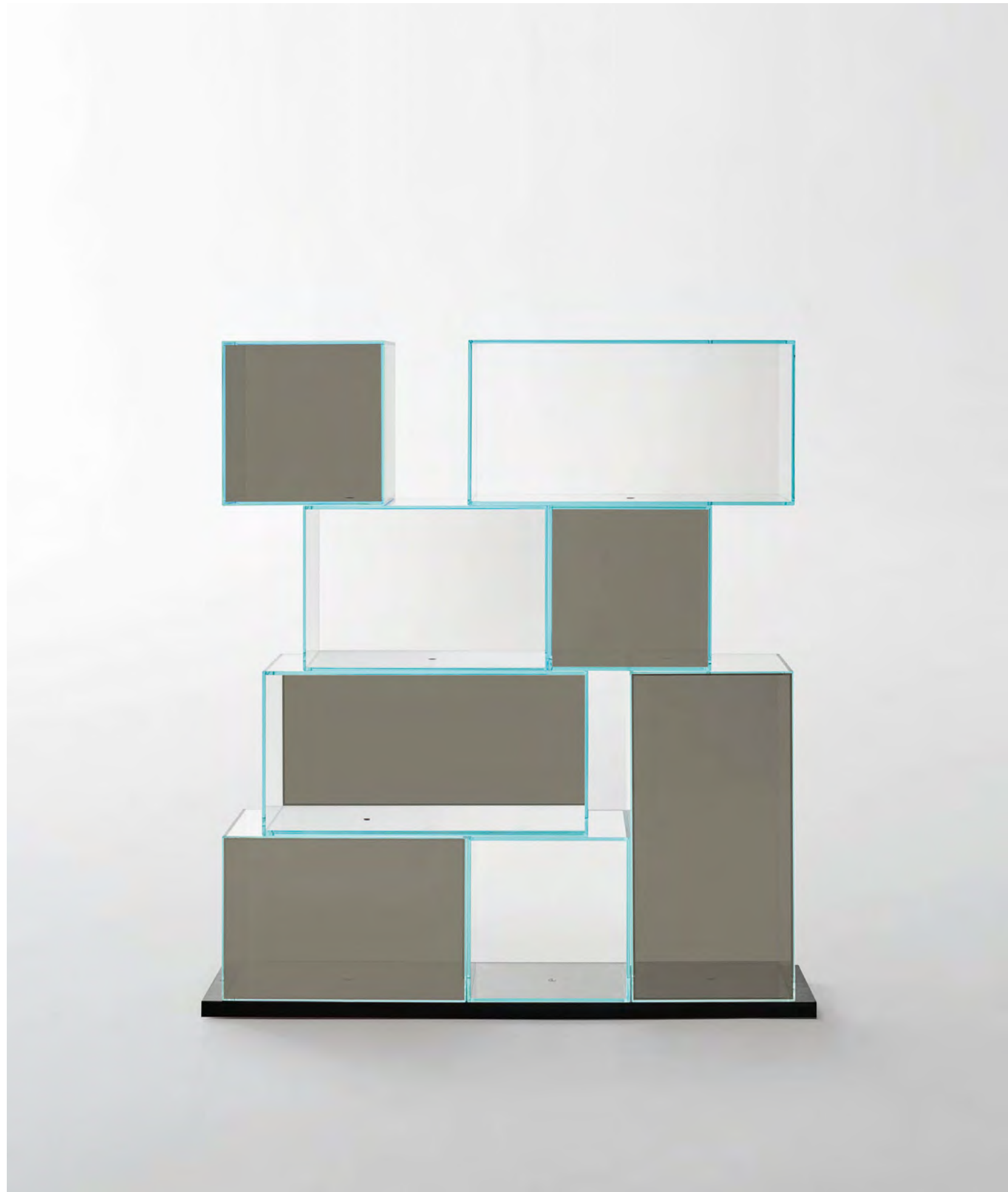



■ ← INDEX





Collezione di tavoli bassi, consolle e mobile contenitore completamente realizzati in uno speciale cristallo specchiante su entrambe le facce, con un pattern decorativo a bolli trasparenti, che simula una lamiera traforata. Tutti i cristalli sono temperati e incollati a UV. Il contenitore è chiuso da due antine con sistema di chiusura push-pull.

Dimensioni:

ROB02 L 164 P 51 H 71

Collection of low tables, consoles and storage furniture, completely created from a special double-sided mirrored glass, with a decorative pattern made from round transparent marks, simulating a perforated metal sheet. All the glass is tempered and UV bonded. The two doors are opened and closed with a push-pull system.





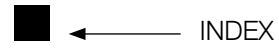

Libreria componibile con moduli mono o bifacciali di diversa larghezza e profondità in cristallo temperato 10 mm. Le spalle e i ripiani sono in cristallo trasparente extralight. La base e il cielino sono in cristallo laccato lucido. Lo schienale è trasparente extralight.

Finiture: cristalli laccati lucidi



Dimensioni:

LSP01 L 62 P 31 H 220
 monofacciale con due spalle e schienale /
 single face with two sides and back
LSP02 L 32 P 31 H 220
 monofacciale con due spalle e schienale /
 single face with two sides and back
LSP03 L 61 P 31 H 220
 monofacciale con una spalla e schienale /
 single face with one side and back
LSP04 L 31 P 31 H 220
 monofacciale con una spalla e schienale /
 single face with one side and back
LSP05 L 62 P 31 H 220
 monofacciale con due spalle senza schienale /
 single face with two sides without back
LSP06 L 32 P 31 H 220
 monofacciale con due spalle senza schienale /
 single face with two sides without back

LSP07 L 61 P 31 H 220
 monofacciale con una spalla senza schienale /
 single face with one side without back
LSP08 L 31 P 31 H 220
 monofacciale con una spalla senza schienale /
 single face with one side without back
LSP09 L 62 P 63 H 220
 bifacciale con due spalle e schienale /
 double face with two sides back
LSP10 L 32 P 63 H 220
 bifacciale con due spalle e schienale /
 double face with two sides back
LSP11 L 61 P 63 H 220
 bifacciale con una spalla e schienale /
 double face with one side back
LSP12 L 31 P 63 H 220
 bifacciale con una spalla e schienale /
 double face with one side back

Composable single or double faced bookcase with modules of various width and depth in tempered 10 mm thick glass. The sides and the glass plates are in transparent extralight. The base and the top are in glossy lacquered glass. The back is in transparent extralight.

Finishes glossy lacquered glasses



■ ← INDEX



Espositore, contenitore ed elemento di divisione e schermatura degli spazi, realizzato incollando lastre di cristallo stratificato 5+5 mm. Disponibile in cristallo trasparente extralight o trasparente colorato.

Finiture: cristallo trasparente extralight / cristalli trasparenti colorati



Dimensioni: TRX L 115 P 32 H 150

Display and storage unit and element dividing and screening the spaces, obtained by gluing slabs of laminated 5+5 mm glass. Available in transparent extralight glass or transparent coloured glass.

Finishes: transparent extralight glass / transparent coloured glass



INDEX ←





Collezione di vetrine-espositori con una struttura in alluminio anodizzato dark brown, dai dettagli molto curati, e pannellature in cristallo trasparente extralight temperato. La base è rivestita da un cristallo laccato opaco. I ripiani vengono sostenuti da staffe regolabili fissate a due montanti verticali, sui quali va in battuta l'antina provvista di speciali cerniere registrabili. Questi pezzi, a richiesta forniti con serratura e completamente smontabili, sono ideali per contesti museali e commerciali e, grazie al cristallo extralight e all'esilità della struttura, garantiscono una perfetta visibilità a 360° degli oggetti contenuti. Disponibili su misura. Fornite anche con un impianto luminoso ad alta resa cromatica, completamente integrato nei profili del telaio superiore (tonalità della luce 3.500°K – 20W/m).

Dimensioni:
Versione A / Version A: H 75 P 50/55
WUNA1 L da / from 160 a / to 200

Versione B / Version B: H 175 P 50/55
WUNB1 L da / from 120 a / to 150

WUNB2 L da / from 151 a / to 180

WUNA2 L da / from 201 a / to 270

WUNB3 L da / from 181 a / to 210

WUNB4 L da / from 211 a / to 240

Collection of display cases-storage units with a structure in dark brown anodized aluminium with highly finished details and tempered transparent extralight glass panels. The base is covered with opaque lacquered glass. The shelves are supported by adjustable brackets fixed to two vertical pillars that are used as a striker for the door, which is supplied with fully adjustable hinges. These products, provided on demand with lock and completely disassembled, are perfect for museums and shop display uses. The transparent extralight glass and the thinness of the structure allow a perfect 360-degree visibility of the objects within. Available in custom size. Supplied optionally with a lighting system with high colour performance, completely integrated into the profiles in the upper frame (light intensity 3500° k-20 W/m).







SPECCHI / MIRRORS





Riedizione della prima collezione di specchi disegnata da Nanda Vigo per Glas Italia, presentata nel 1974. Si tratta di una collezione di specchi in negativo-positivo (parti trasparenti si alternano a parti specchianti) di varie forme e misure, disponibili in finitura neutra o in uno speciale cristallo colore ambra. Il sistema di appensione permette di orientare i pezzi in varie direzioni.

Dimensioni:

691C6	Ø 60	P 5		
692C6	Ø 60	P 5		
693C6	Ø 60	P 5		
694C6	Ø 60	P 5		
695C6	Ø 60	P 5		
691C8	Ø 80	P 5		
692C8	Ø 80	P 5		
693C8	Ø 80	P 5		
694C8	Ø 80	P 5		
695C8	Ø 80	P 5		
691C9	Ø 90	P 5		
692C9	Ø 90	P 5		
693C9	Ø 90	P 5		
694C9	Ø 90	P 5		
695C9	Ø 90	P 5		
681Q8	L 80	P 5	H 80	
682Q8	L 80	P 5	H 80	
683Q8	L 80	P 5	H 80	
684Q8	L 80	P 5	H 80	
685Q8	L 80	P 5	H 80	
686Q8	L 80	P 5	H 80	
651R	L 65	P 5	H 90	
652R	L 65	P 5	H 90	
653R	L 65	P 5	H 90	
654R	L 65	P 5	H 90	
151L	L 50	P 5	H 150	
152L	L 50	P 5	H 150	
153L	L 50	P 5	H 150	

Re-launch of the first collection of mirrors designed by Nanda Vigo for Glas Italia, initially presented in 1974. It is a collection of mirrors in negative-positive (transparent parts alternate with mirrored parts) in various shapes and sizes, available in a neutral finish or in unique amber-colored glass. The hanging system allows you to install the mirrors in various inclinations.



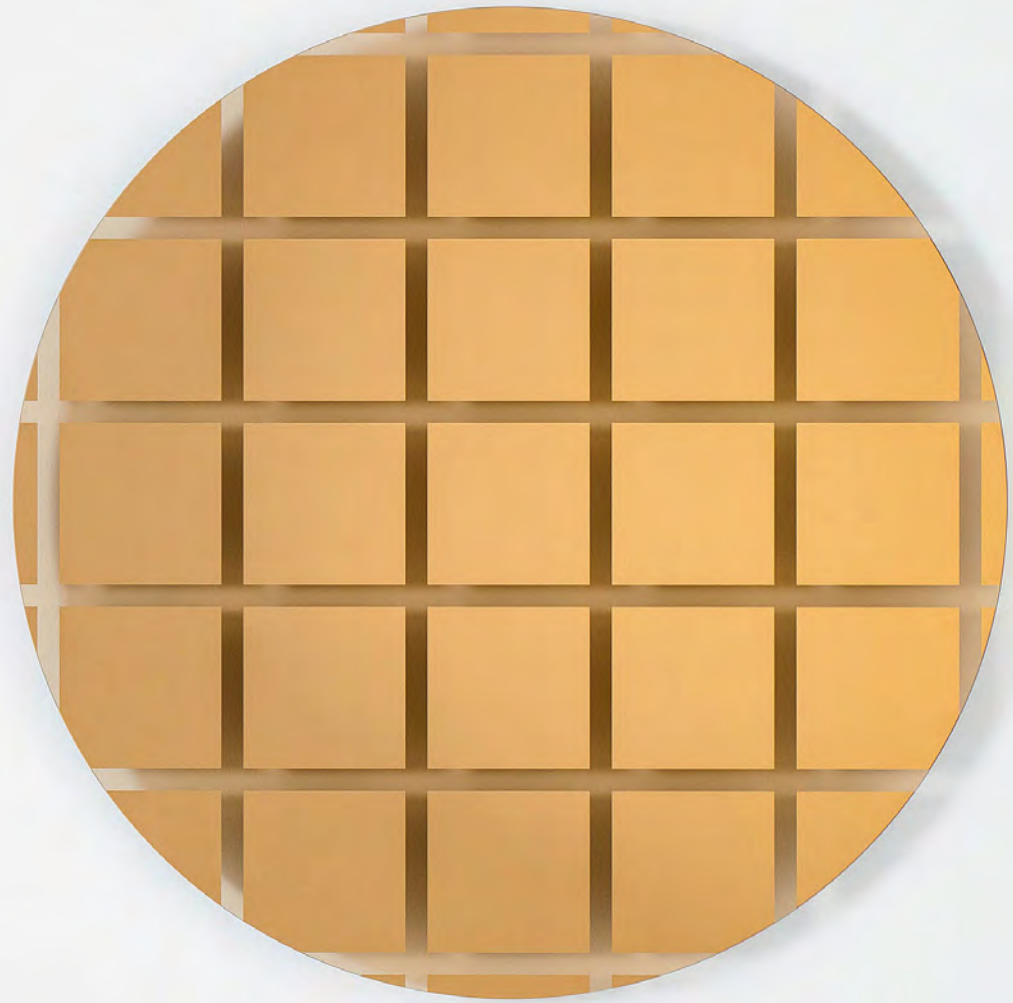

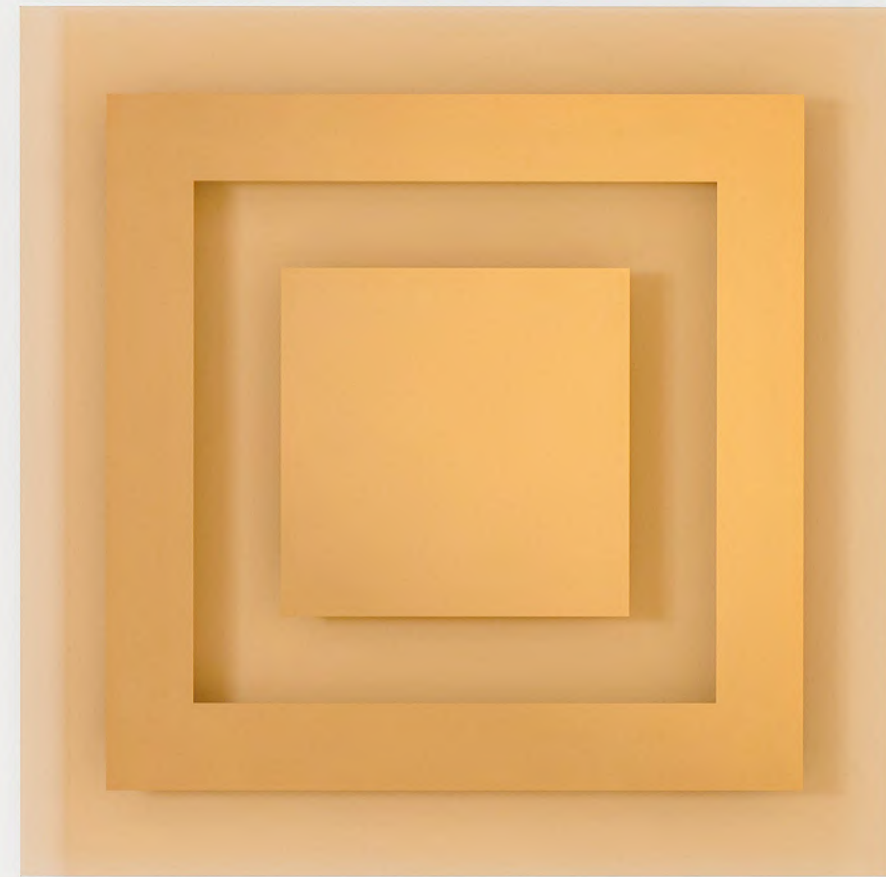







INDEX ←





Serie di specchi con bordi perimetralmente bisellati con una profondità di 3 cm. Le forme rettangolari e ovali sono fornite di doppi attacchi orizzontali e verticali.



Dimensioni:

SB01	L 90	H 180	SB05	ø 80
<i>ovale / oval</i>			SB06	ø 60
SB02	L 70	H 140	SB12	L 50
<i>ovale / oval</i>				H 150
SB04	ø 120			



Set of mirrors which external edges are chamfered with a depth of 3 cm. The oval and rectangular-shaped mirrors have a double horizontal and vertical fixture.





■ ← INDEX





Serie di specchi in cristallo sagomato con decorazioni incise.

Dimensioni:

SBR01 L 90

H 118

SBR04 L 60

H 164

SBR03 ø 80



A series of mirrors in shaped crystal with engraved decorations.





← INDEX





Specchio 5 mm in cristallo extralight, disponibile in forma rotonda e ovale. Lo specchio assume un aspetto magnetico e crea effetti surreali, grazie a tre oblò ingranditori su una superficie completamente piana, ognuno con diametro e grado di ingrandimento differenti. Un delicato bisello perimetrale rifinisce ed impreziosisce l'oggetto.



Dimensioni: **CEL01** ø 110 P 3

CEL02 L 87 P 3 H 160



5 mm extralight mirror available in round or oval shapes. The mirror assumes a magnetic aspect creating surreal effects thanks to three magnifying portholes fixed on a flat surface with each porthole having a different diameter and different degree of magnification. The mirror has a delicate bevelled edge on its perimeter to refine and enhance the beauty of this object.





INDEX





Specchiera con cornice in ottone massiccio lucidato a specchio e lasciato al naturale (non trattato), in cui si apprezza la qualità e la preziosità del materiale, oppure in ottone verniciato colore Dark Brown o Bamboo green NCS S 3020-G20Y. Lo specchio può essere fornito con un bisello perimetrale raggato negli angoli, in modo da seguire perfettamente la sagoma della cornice, oppure senza. Sono disponibili due versioni, una a pannello singolo e l'altra con tre pannelli vincolati tra di loro per mezzo di cerniere a perno, integrate nelle cornici e rifinite nei minimi dettagli. Il pannello centrale è fissato alla parete, mentre quelli laterali ruotano per poter rimanere parzialmente e completamente aperti. Quando i pannelli laterali sono richiusi, gli specchi vengono nascosti come in un prezioso scrigno, lasciando in vista il lato posteriore, elegantemente rifinito in cristallo laccato opaco.

Dimensioni:	COMO01	L 147	H 160	COMO03	L 147	H 70
	COMO02	L 48	H 160	COMO04	L 48	H 70

Mirror with frame in shiny-polished untreated solid brass, to fully appreciate the quality and preciousness of the material, also available in Dark Brown or Bamboo green NCS S 3020-G20Y lacquered brass. The mirror is supplied with a beveled perimeter with rounded corners, perfectly following the shape of the frame or without the bevel. Available in two versions, one with a single panel and the other with three panels joined together by means of pin-hinges integrated into the frames and finished down to the finest details. The central panel is fixed to the wall, while the side panels rotate allowing them to be partially or completely open. When the side panels are closed, the mirrors are hidden as in a precious treasure chest, leaving the rear side visible, elegantly refined in matt lacquered glass.



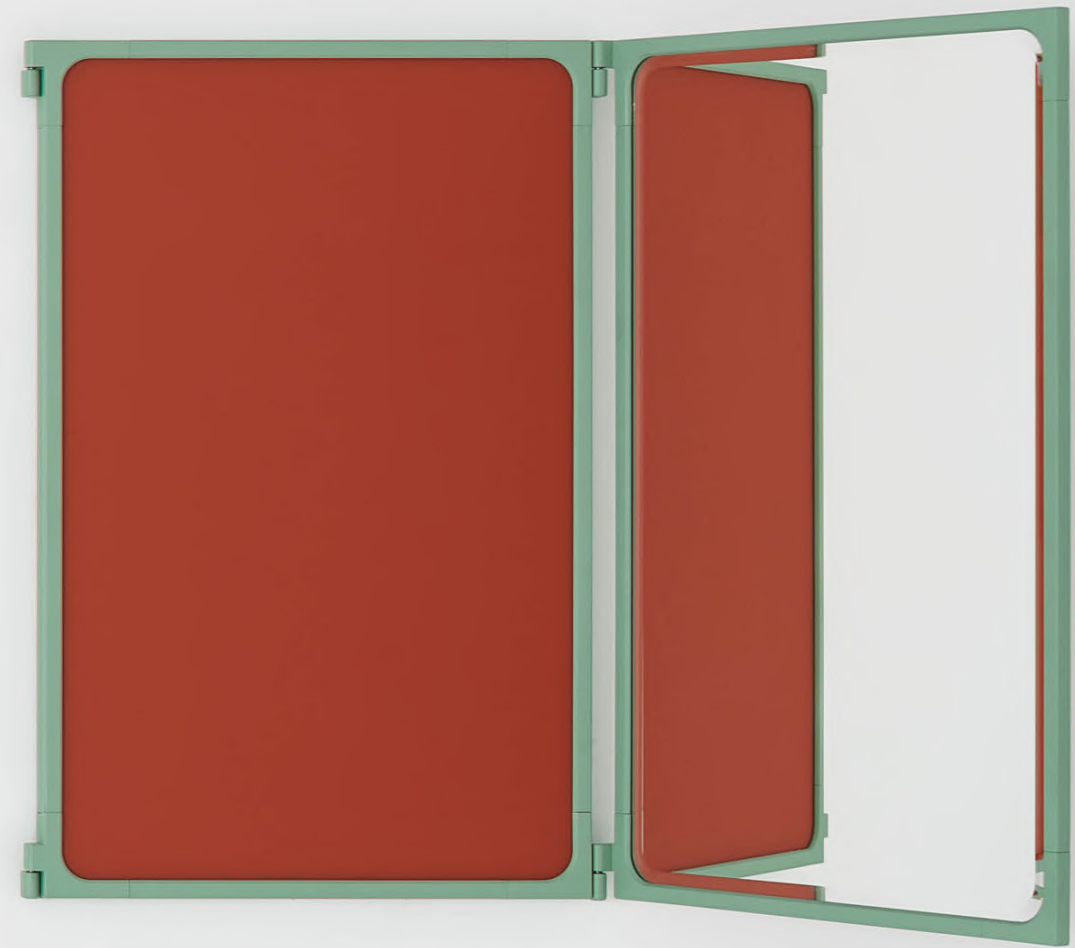
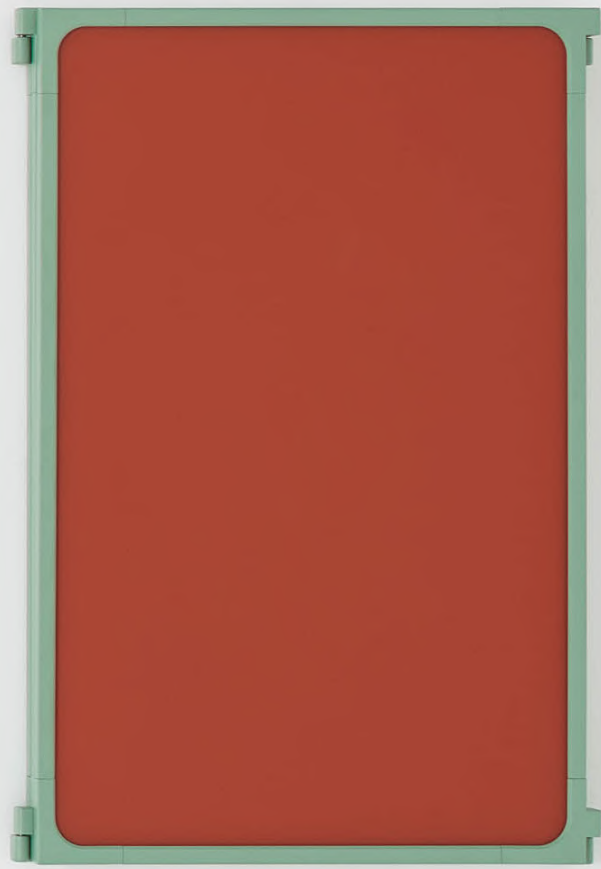





INDEX ←





Serie di specchi eseguiti con lastre di cristallo decorate, in parte specchianti ed in parte laccate lucide, rappresentanti proiezioni di figure geometriche. Disponibili con doppi attacchi orizzontali e verticali.

Finiture: cristalli laccati lucidi

Dimensioni:	CB08	L 60	H 160	PL04	L 65	H 165
	CB02	L 90	H 100	PR04	L 90	H 100

A series of geometrically shaped mirrors made out of partly reflecting and partly glossy lacquered glass slabs. Available with double vertical and horizontal fixture.

Finishes: glossy lacquered glass







INDEX ←





Specchio da terra realizzato in cristallo fumè incollato. La parte superiore ed inferiore è trasparente mentre la parte centrale ha una speciale specchiatura attraverso cui si vede la traccia luminosa di una lampada posizionata sul retro. La lampada si accende e si spegne tirando un cordone di colore rosso.



Dimensioni: **DIV** L 50 P 8 H 200



Standing mirror realized in glued smoked glass. The upper and lower part is transparent while the central part has a special mirroring effect through which the luminous trace of a lamp placed on the backside can be seen. It is possible to switch on and off the lamp by pulling a red cord.





INDEX





Specchio da terra in cristallo extralight 12 mm, rifinito alle estremità superiore e inferiore da due barre cilindriche verniciate con effetto gomma nei colori giallo, verde o arancione. Sullo specchio è applicata una lampada dimmerabile a led di alta qualità, dall'eccellente resa cromatica. Il diffusore sferico è in vetro di Murano soffiato a bocca, di colore opalino bianco in finitura satinata. Il cavo è spiralato e rivestito in tessuto di diversi colori, coordinati con le cromie delle barre: cavo verde kiwi con barre verde mimetico, cavo turchese con barre gialle, cavo verde mimetico con barre arancioni. L'interruttore e il potenziometro sono posizionati sul retro dello specchio.

Dimensioni: **ECC01** L 66 P 22 H 205

Floorstanding mirror in 12 mm extralight glass, with detailed upper and lower edges of two cylindrical bars painted with rubber effect in the colours: yellow, green or orange. On the mirror there is a high quality dimmable Led light with excellent colour performance. The opaline white cylindrical diffuser is in Murano mouth blown glass in a satin finish. The spiral shaped cable is wrapped in a coloured fabric matching the finish of the cylindrical bars: green kiwi cable with camouflage green bars, turquoise cable with yellow bars, camouflage green cable with orange bars. The on/off and dimmer switches are on the back of the mirror.



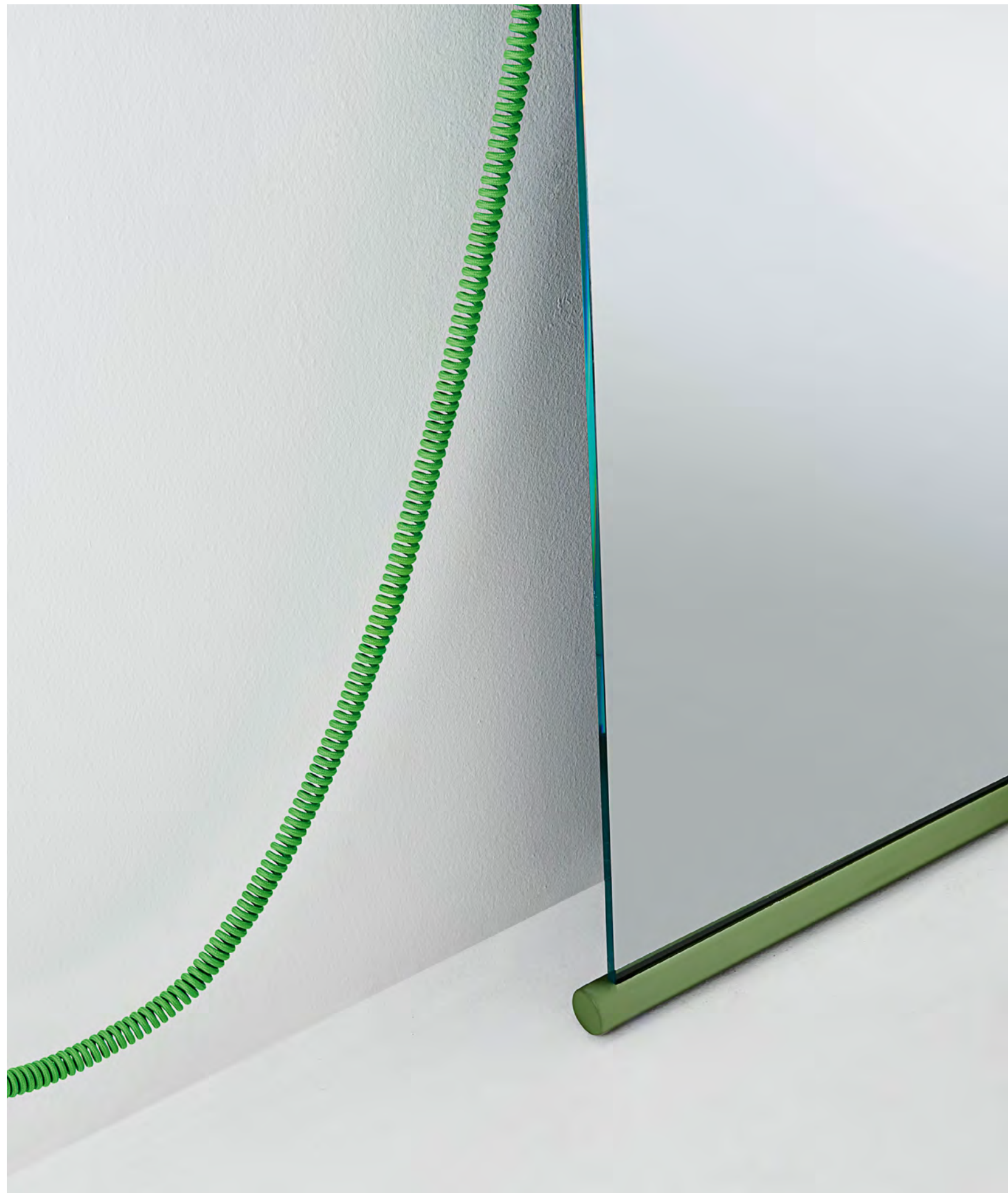



■ ← INDEX





Specchiera da terra con specchio di cristallo e cornice con impiallacciatura Alpi. Mensola e basamento in legno verniciato all'anilina su base Alpi, con elementi cilindrici con finitura a foglia oro. Ogni pezzo è identificato da una numerazione progressiva.



Dimensioni: **ETR** L 120 P 45 H 205



Mirror unit with crystal mirror and Alpi veneer frame. The shelf and the base are in aniline-veneered wood with goldplated cylindrical elements. Every piece is identified by a progressive numbering.





INDEX ←





Serie di specchi disponibili in due misure differenti, realizzati in cristallo extralight con argentatura sfumata digradante, appesi a parete con una barra retro incollata e un cilindro in metallo cromato. Lo specchio piccolo può avere sfumatura digradante verso l'alto o verso il basso.

Dimensioni:

FIC01 L 60 P 7 H 105

FIC02 L 60 P 7 H 180

Series of mirrors available in two different sizes, realized in extralight glass with degrading shaded silvering, hanging on the wall with a back glued bar and with a chromium-plated metal cylinder. The small mirror can have a degrading shade upwards or downwards.







■ ← INDEX





Specchiera da terra bifacciale girevole, realizzata incollando lastre di specchio con fasce di cristallo laccato lucido molato a 45°. La base è in metallo satinato grigio.

Finishes: cristalli laccati lucidi

Dimensioni: SGI01 L 50 P 50 H 180



Standing double faced revolving dressing mirror, made with glued mirror plates with 45° chamfered glossy lacquered glass bands. The base is in satin plated grey metal.

Finishes: glossy lacquered glass





INDEX ←





Collezione di 6 specchi a parete di varie forme e misure caratterizzati da cornici policrome composte da elementi in specchio laminato colorato, in cristallo laminato colorato e in cristallo laccato.

Dimensioni:

DIONISO1	L 60	H 58	DIONISO4	L 72	H 52
DIONISO2	L 70	H 64	DIONISO5	L 69	H 69
DIONISO3	L 52,5	H 50	DIONISO6	L 63	H 72

Collection of 6 wall mirrors in different shapes and sizes characterizes by polychromatic frames composed of elements in laminated coloured mirror, coloured laminated glass and lacquered glass.



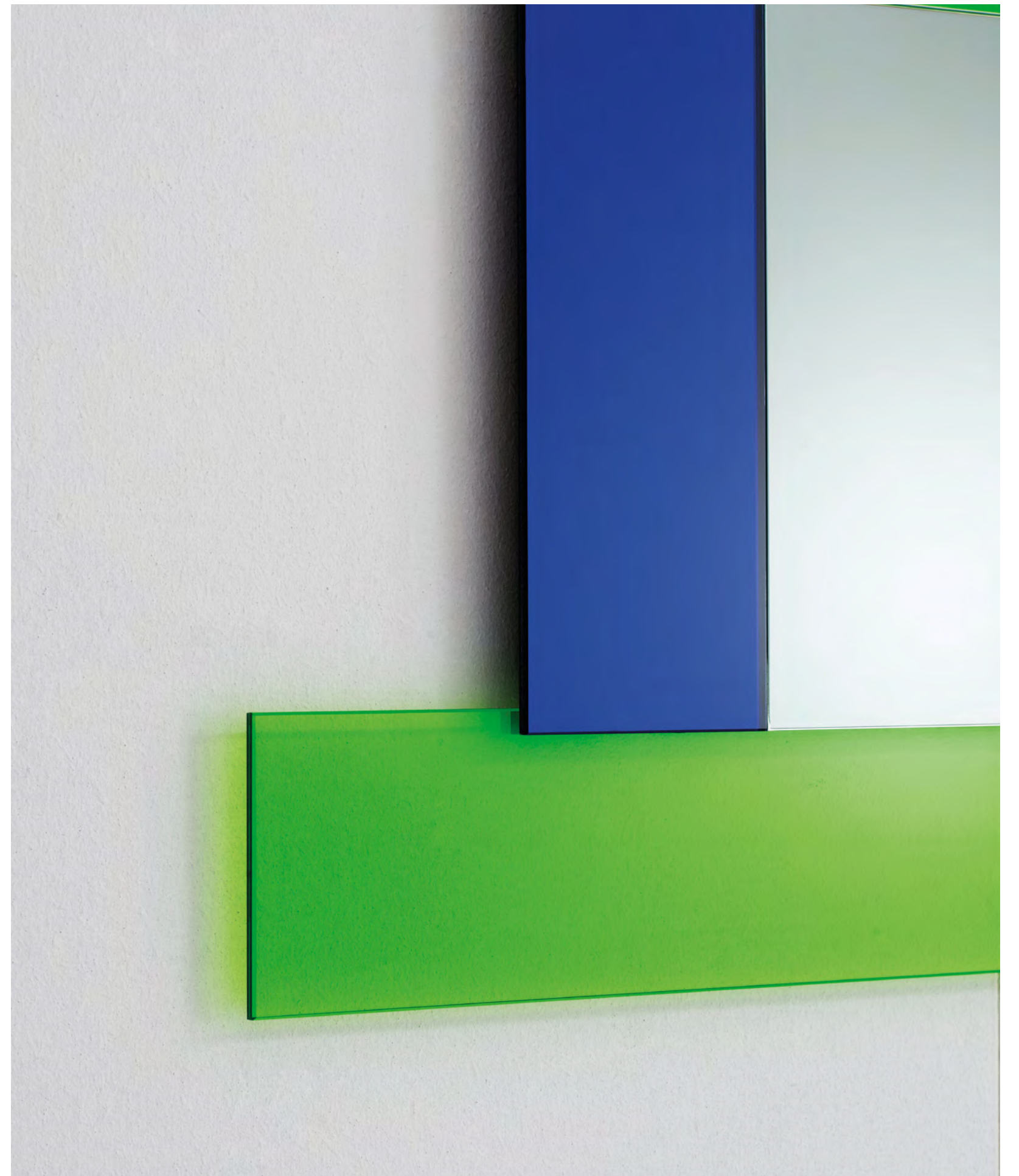



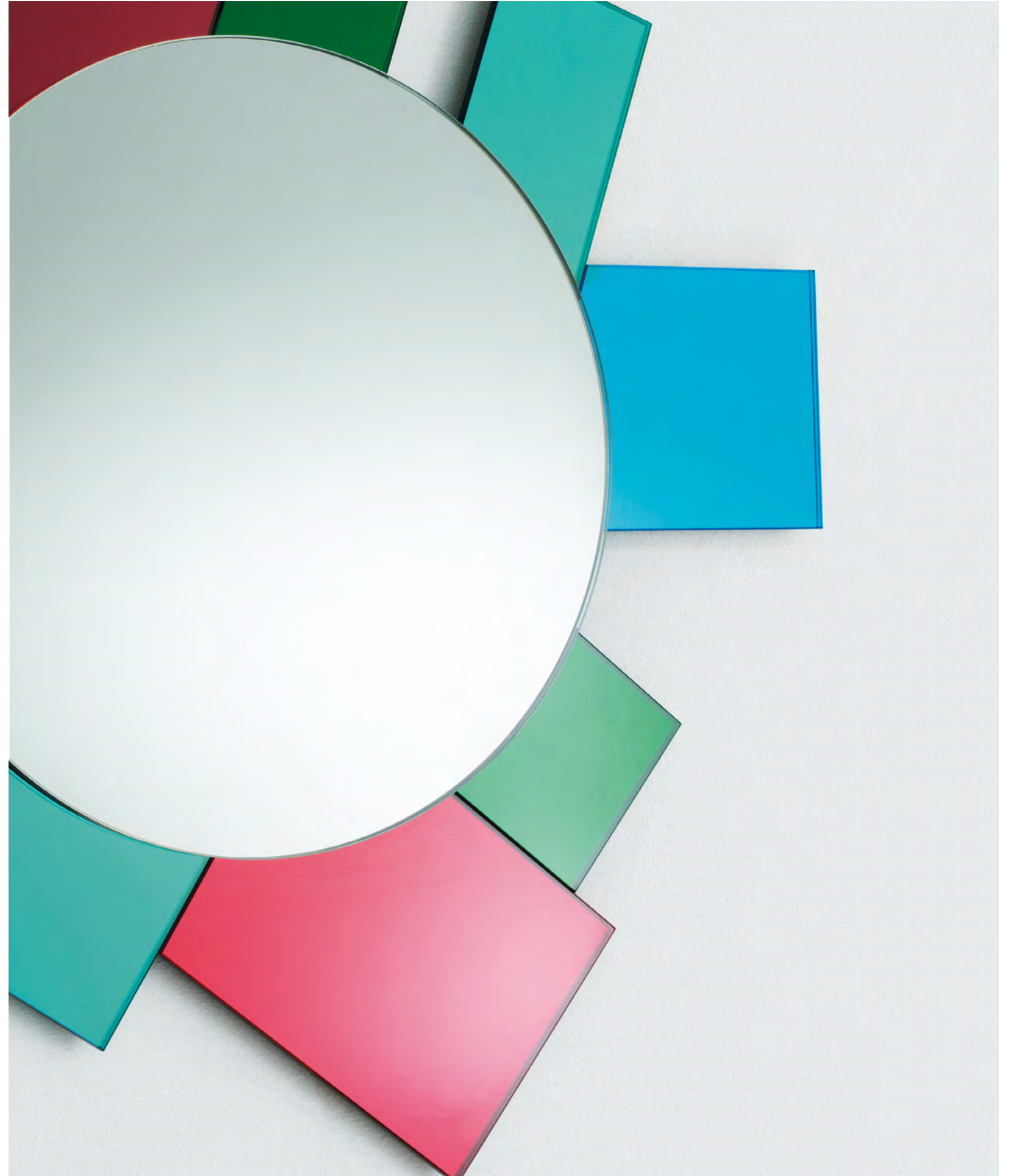
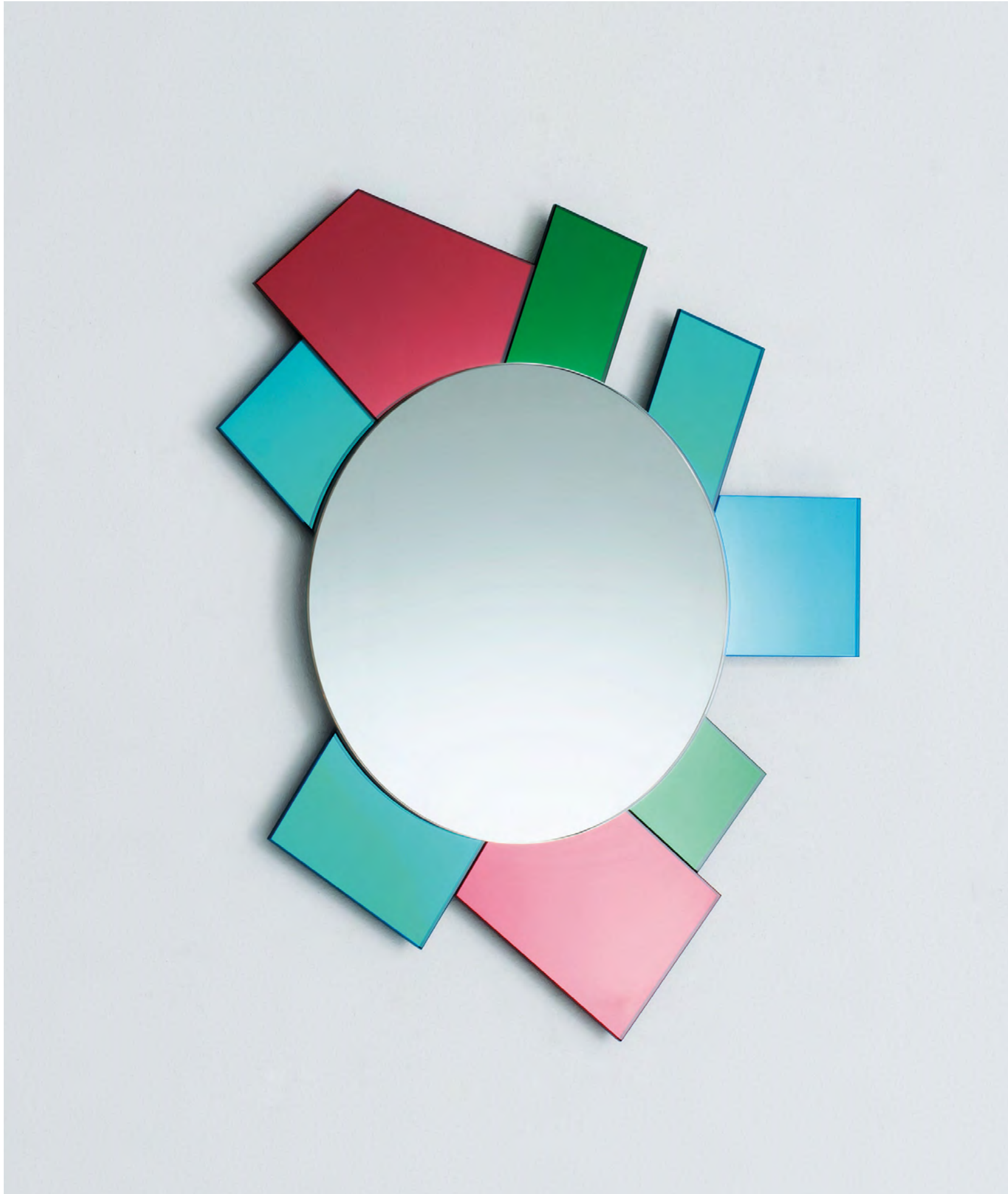





INDEX





Parallelepipedi realizzati incollando lastre di specchio bisellato a 45°, così da ottenere un aspetto monolitico. Nella versione con impianto d'illuminazione al neon bianco, una corona di luce fuoriesce dal retro dello specchio. E' disponibile anche senza illuminazione. Fornito di doppi attacchi orizzontali e verticali.



Dimensioni:

SMA01 L 67 P 19 H 201
SMA02 L 72 P 19 H 72

SMA03 L 72 P 19 H 133
SMA04 L 103 P 19 H 103



Parallelepipeds obtained by gluing 45° chamfered mirror slabs, so as to get a monolithic figure. In the version with lighting installation with white neon, a circle of light pours out from the back of the mirror. It is also available without lighting. Supplied with double horizontal and vertical fixture.



INDEX





Specchio da terra di forma irregolare con perimetro sfaccettato, con speciali bisellature dalle profondità e inclinazioni variabili.

Dimensioni:

KOS01 L 116

H 206

KOS02 L 150

H 265

Standing mirror irregularly shaped with faceted perimeter and special chamferings with variable depths and inclinations.







INDEX





Specchiera a forma di sfondato prospettico, disponibile in tre diverse misure. La cornice convergente è in specchio ed ha tutti i lati con larghezze ed inclinazioni differenti, ottenendo così riflessi scomposti ed inaspettati. Tutti gli specchi possono essere appesi in qualsiasi verso.



Dimensioni:

LEO01 L 85 P 11 H 200
LEO02 L 72 P 11 H 102

LEO03 L 52 P 10 H 72



Mirror shaped in an artificial perspective, creating a "sfondato" effect, available in three different sizes. The converging frame is in mirrored glass and each side has different widths and inclinations, generating in this way fragmented and unexpected reflections. Each mirror can be hung in any direction.





■ ← INDEX





Sagoma di componenti architettoniche virtuali: specchio a forma di lesena. Disponibile con doppi attacchi orizzontali e verticali.

Dimensioni: SL01 L 70 H 170

Silhouette of virtual architectural components: mirror in the shape of a pilaster strip. Available with double vertical and horizontal fixture.





INDEX ←





Specchi realizzati in un'unica lastra di cristallo extrachiaro o blu ondulato alle due estremità e argentato manualmente, in modo da simulare lo sventolio di un drappo o la superficie di un liquido mosso da leggere onde. Le zone ondulate riflettono le immagini distorcendole in maniera inaspettata, mentre la zona al centro, perfettamente piana, garantisce un riflesso fedele e un utilizzo funzionale. Gli specchi, disponibili in due misure, possono essere appesi liberamente in qualsiasi direzione. MAE01, fornito con un set di piedini, può essere posizionato anche a terra.



Dimensioni:

MAE01 L 115 P 11 H 196

MAE02 L 115 P 11 H 90



Mirrors created from a single sheet of extralight or blue glass, undulating at both ends and hand-silvered, simulating the fluttering of a drape or the surface of a liquid moved by slightly waves. The undulating reflected images are distorted in an unexpected way, whilst the perfectly flat area in the center guarantees a faithful reflection and a functional use. The mirrors, available in two sizes, can be freely hung in any direction. MAE01, supplied with a set of feet, can also be placed on the ground.







INDEX ←





Specchiera incorniciata da una profilatura specchiante che crea profondità, inserita in una cornice di legno di radica di pioppo.



Dimensioni: **SMS** L 88 P 6 H 76



Framed mirror with a reflecting bordering which gives depth. The mirror is inserted in a poplar root wooden frame.





INDEX





Serie di specchi a parete di grande eleganza, ottenuti curvando una lastra di cristallo extralight 6 mm, sagomato e molato filo lucido, e argentandola manualmente. La parte centrale e le due ali laterali riflettono l'immagine in maniera fedele e funzionale, mentre le superfici curve deformano l'immagine in maniera inaspettata. Il retro dello specchio è disponibile nei colori rosa, bianco o argento. I codici MAR03 e MAR04 possono essere appoggiati a terra tramite piedini cromati in dotazione.

Dimensioni:

MAR01 L 75 P 12 H 77
MAR02 L 100 P 17 H 56

MAR03 L 95 P 20 H 185
MAR04 L 150 P 34 H 185

A collection of elegant wall mirrors, created by bending a slab of extralight 6 mm glass, moulded and shiny ground polished and then manually silvered. The central part and the two lateral sides give true reflection, whilst the curved part of the surface distorts the reflection randomly and unexpectedly. The back of the mirror is available in pink, white or silver colour. The codes MAR03 and MAR04 can be placed on the floor by means of the supplied chromed feet.





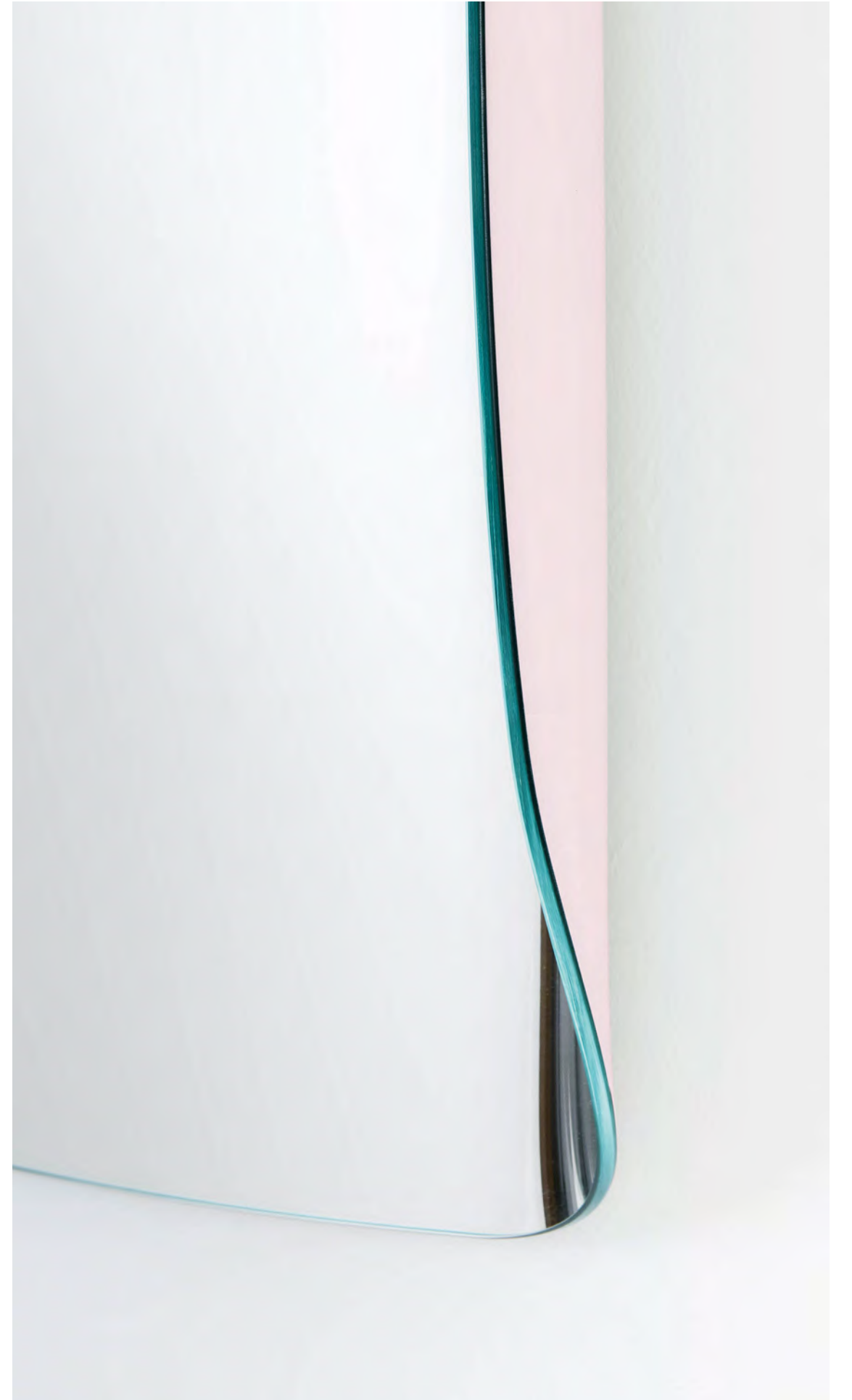



INDEX ←





Dimensioni:

<i>convesso</i> MENT01	L 85	P 5	H 175	<i>convesso</i> MENT03	ø 80	P 5
<i>concavo</i> MENT02	L 85	P 5	H 175	<i>concavo</i> MENT04	ø 80	P 5



Mirrors made from a single sheet of extra-clear glass, which, thanks to innovative and complex processing techniques, is curved around its entire perimeter and manually silvered to perfection. Depending on the silver face, a mirror with a concave or convex surface is obtained, with a frame reflecting the images and distorting them at random, while the area in the center, perfectly flat, guarantees a true reflection and functional use. Available in two sizes, the rectangular shape can be hung in either direction. The back side of the concave version is available in the colours silver or orange Pantone 163C.

Specchi realizzati in un'unica lastra di cristallo extrachiaro, che, grazie ad innovative e complesse tecniche di lavorazione, è curvata su tutto il perimetro e argentata manualmente a regola d'arte. A seconda della faccia argentata, si ottiene uno specchio dalla superficie concava o convessa, con una cornice che riflette le immagini distorcendole in maniera inaspettata, mentre la zona al centro, perfettamente piana, garantisce un riflesso fedele e un utilizzo funzionale. Disponibili in due formati, la forma rettangolare può essere appesa in entrambe le direzioni. La forma concava è disponibile retro-verniciata nei colori argento o arancio Pantone 163C.









INDEX ←





Collezione di specchi quadrati e rettangolari disponibili in varie misure, realizzati incollando a 45° lastre di specchio stratificato bifacciale. Due misure sono disponibili anche con mensole in cristallo trasparente, termosaldate allo specchio. Tutti gli specchi sono forniti con doppi attacchi verticali e orizzontali.



Dimensioni:

MIR09 L 110 P 13 H 38

MIR10 L 66 P 13 H 50

MIR11 L 68 P 13 H 68

MIR12 L 75 P 13 H 28



Collection of square and rectangular mirrors available in different sizes, realized by gluing 45° laminated double faced mirror slabs. Two sizes are available as well with shelves in transparent glass, heatsealed to the mirror. All the mirrors are provided with double vertical and horizontal fixture.





INDEX ←





Sagoma di componenti architettoniche virtuali: specchio a forma di pannello ondulato. Disponibili con doppi attacchi orizzontali e verticali.

Dimensioni:	SO01	L 140	H 80	SO03	L 50	H 160
	SO02	L 80	H 80			

Silhouette of virtual architectural components: a mirror shaped like an undulating panel. Available with double vertical and horizontal fixture.





INDEX ←





Specchio bifacciale da appendere a soffitto disponibile in tre formati che, grazie ad un sistema di contrappesi, cavi e carrucole, può essere spostato verticalmente con grande semplicità. I contrappesi, che salgono o scendono bilanciando il movimento dello specchio, sono dei cilindri in vetro soffiato di colore rosso o cristallo neutro. I cavi e le carrucole d'alluminio sono di colore nero. Grazie alla sua natura bifacciale, questo specchio si presta ad essere appeso in prossimità di una parete, ma anche al centro di un ambiente come elemento di divisione e schermatura.



Dimensioni:	PAL01	L 50	P 5	H 125	PAL03	L 125	P 5	H 50
	PAL02	L 63	P 5	H 100				



A double-faced mirror hanging from the ceiling available in three versions that, thanks to a system of counterweights, cables and pulleys, can be easily vertically positioned. The counterweights, that go up and down balancing the movement of the mirror, are cylinders in red or neutral blown glass. The cables and pulleys are in black aluminium. Because of the double-faced feature, this mirror is perfect to be hung near a wall, but also in the middle of a location as dividing and/or screening element.





■ ← INDEX





Specchi disponibili nelle forme del rettangolo e dell'ottagono, impreziositi da cornici in cristallo extralight 12 mm argentato, lavorato con brillanti bisellature e sfaccettature.



Dimensioni:

PRI01 L 99 P 8 H 199
rettangolare / rectangular

PRI03 L 99 P 8 H 99
ottagonale / octagonal



Mirrors available in rectangular and octagonal shape, embellished by a frame in silver-plated transparent extralight glass 12 mm, decorated with shiny chamfers and facets.





INDEX ←





Serie di specchi con contorno in cristallo trasparente extralight, sagomato a forma di cornice, traforato a getto d'acqua.

Dimensioni:

ROKOKÓ01	L 61	P 6	H 84	ROKOKÓ03	L 137	P 6	H 100
ROKOKÓ02	L 69	P 6	H 95	ROKOKÓ04	L 160	P 6	H 117

Series of mirrors shaped as a frame, cut with water jet, in transparent extralight glass.







INDEX ←





Serie di specchi con motivi a cornice e decori satinati sulla superficie trasparente che ripetono le riflessioni del vetro. Una bisellatura incisa nello specchio sottolinea l'andamento della cornice. La forma rettangolare è fornita di doppi attacchi orizzontali e verticali.



Dimensioni:

SC01 L 90 P 6 H 160

SC06 L 140 P 6 H 130



Set of mirrors with frame-like motifs and satin-like decorations on the transparent part, which repeat the reflections of glass. The cut chamfered edge enhances the frame motif. The rectangular shaped mirror has a double horizontal and vertical fixture.





■ ← INDEX





Specchio in cristallo extralight 5 mm, caratterizzato da un gesto artistico e ironico. La superficie specchiante, infatti, è come se fosse disegnata a mano libera con un pennello su un fondo neutro di colore nero, oppure rivestito con una preziosa foglia d'argento anticata. Lo specchio può essere appeso in tutte e quattro le posizioni.

Dimensioni:

SCRI01 L 60 H 60
SCRI02 L 75 H 100

SCRI03 L 80 H 180

Mirror produced in 5mm thick extralight glass, characterized by an artistic and ironic sign. The mirrored surface, in fact, is as if it were drawn freehand with a brush on a neutral black background or coated with a precious antiqued silver leaf. The mirror can be hung in all four positions.









INDEX ←





Specchio in cristallo sagomato con decorazione policroma.

Dimensioni:

SSV01 L 92 H 125
verde - azzurro / green - light blue
SSV02 L 92 H 125
ocra - marrone / ochre - brown

SSV03 L 92 H 125
grigio - nero / grey - black

A shaped crystal mirror with multicolored decoration.







INDEX ←





Specchiera a totem con mensola porta oggetti. Le due facciate sono in specchio bianco mentre i fianchi sono in specchio decorato con sottili incisioni colorate (disponibili nei colori rosa e azzurro). Il basamento è in granito nero assoluto levigato opaco.



Dimensioni: SHIBAM01 L 88 P 32 H 176



Totem mirror with object holder shelf. The two frontal sides are in white mirror and the lateral ones in decorated mirror with thin coloured engravings (available in the colours pink and light blue). The base is in matt polished absolute black granite.





INDEX ←





Specchiera a totem con lampadine rosse e bianche. I fianchi e le facciate sono in specchio parzialmente decorato con sottili incisioni bianche che girano su tutto il perimetro. Il basamento è in granito nero assoluto levigato opaco.

Dimensioni: SHIBAM02 L 72 P 32 H 176

Totem mirror with red and white bulbs. The lateral and frontal sides are in mirror partially decorated with thin white engravings going around the whole perimeter. The base is in matt polished absolute black granite.



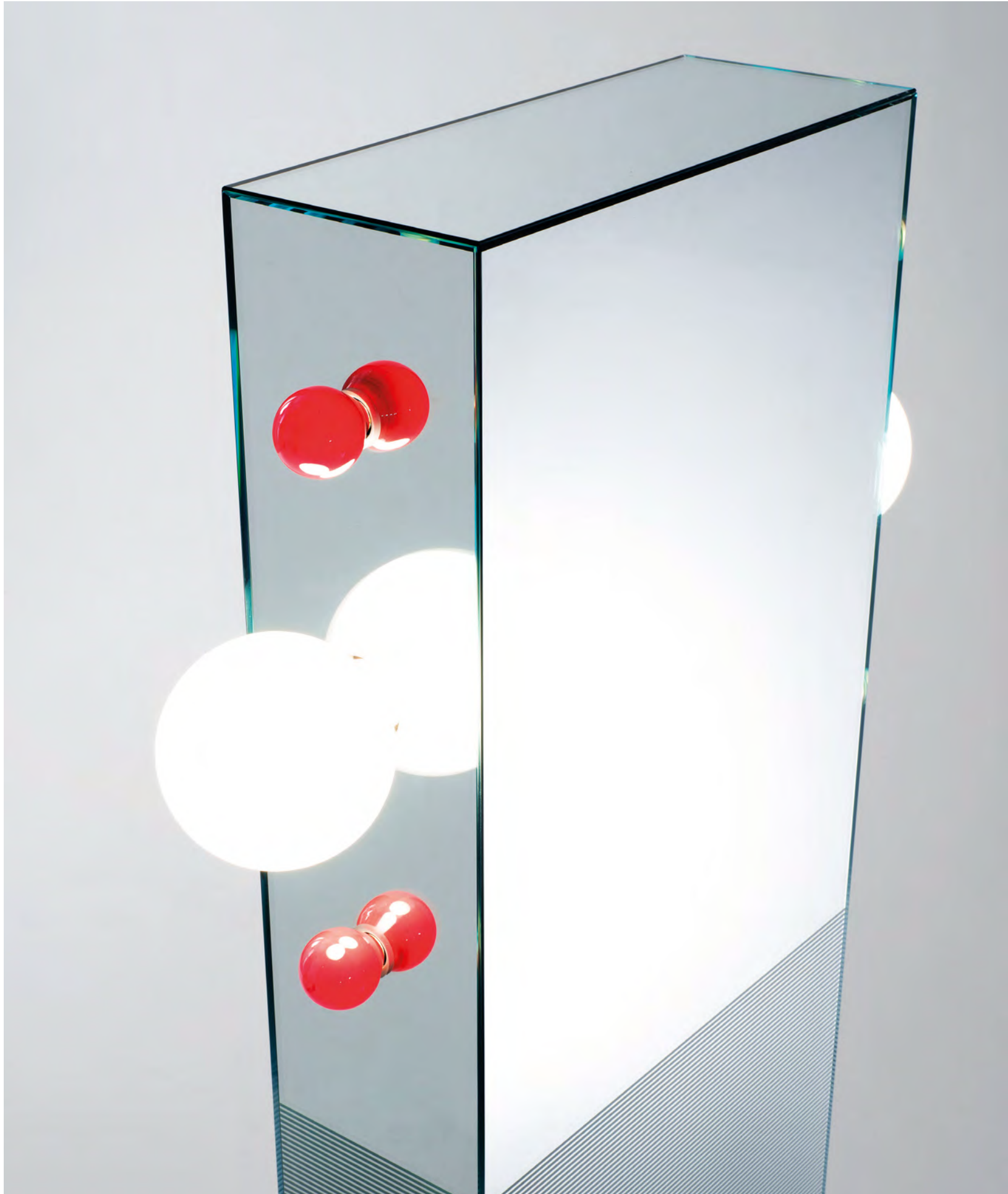



INDEX





Serie di specchi realizzati in cristallo extralight, nei quali, con sofisticate tecniche di lavorazione, si integrano e si fondono una specchiata sfumata digradante e la meravigliosa finitura multicromatica cangiante, caratteristica della collezione Shimmer. Ne risulta uno specchio magico ed ammaliante, dall'aspetto animato, continuamente mutevole al variare dell'incidenza della luce e del punto di osservazione. Ad eccezione del modello SHS03, è disponibile anche una versione con impianto luminoso.

Dimensioni:

SHS01 L 100 P 5 H 80
SHS02 L 125 P 5 H 100
SHS03 L 100 H 180

SHS04 ø 60 P 5
SHS05 ø 80 P 5



A series of mirrors in extralight glass. Made with refined processing techniques, a degrading shaded silvering mix and the magnificent iridescent multichromatic finish, a feature of the Shimmer collection. A magical, fascinating and animated mirror, continuously variable according to the angle of the light source and the vantage point. Except model SHS03, the mirrors are available with a light system.

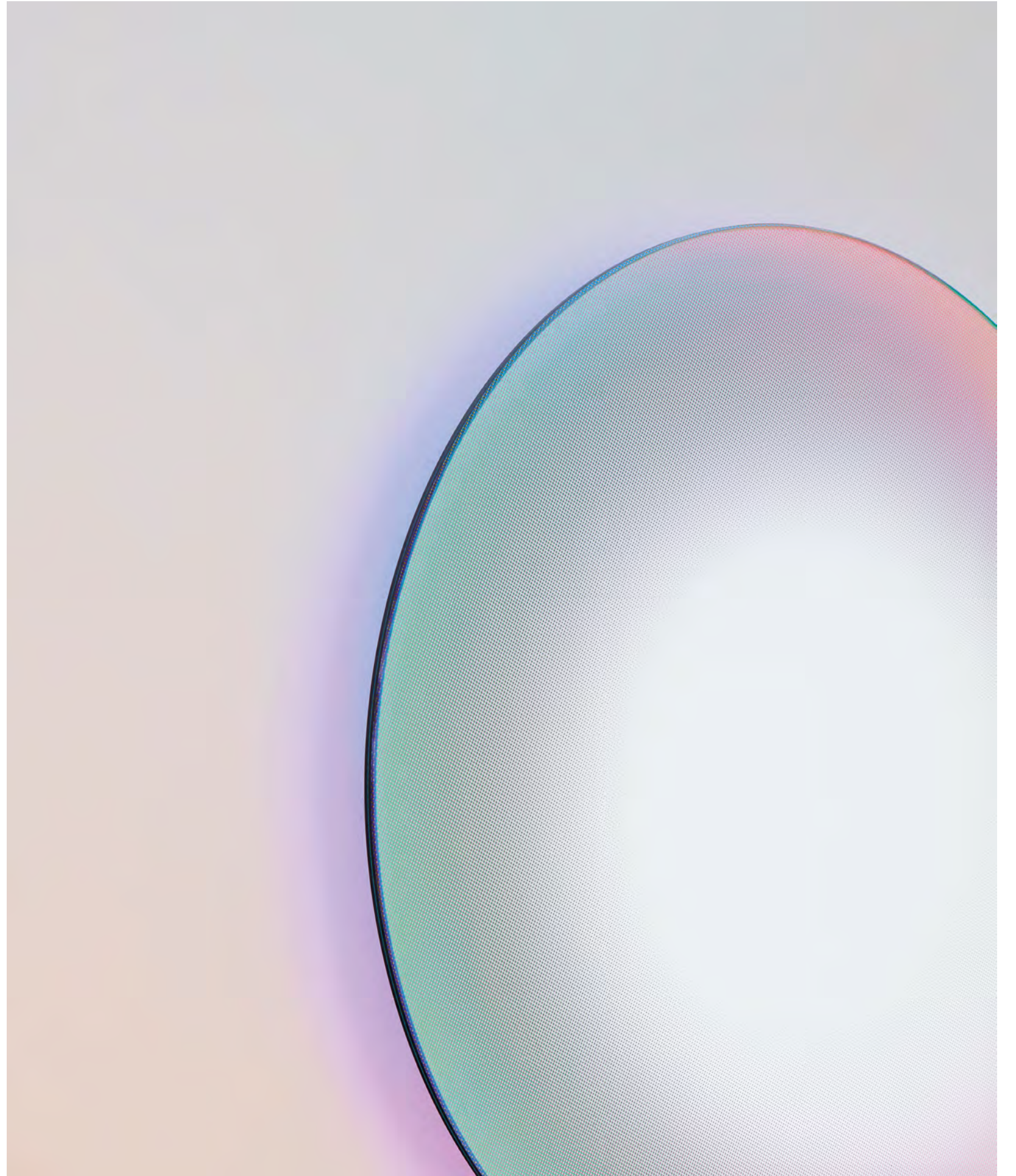



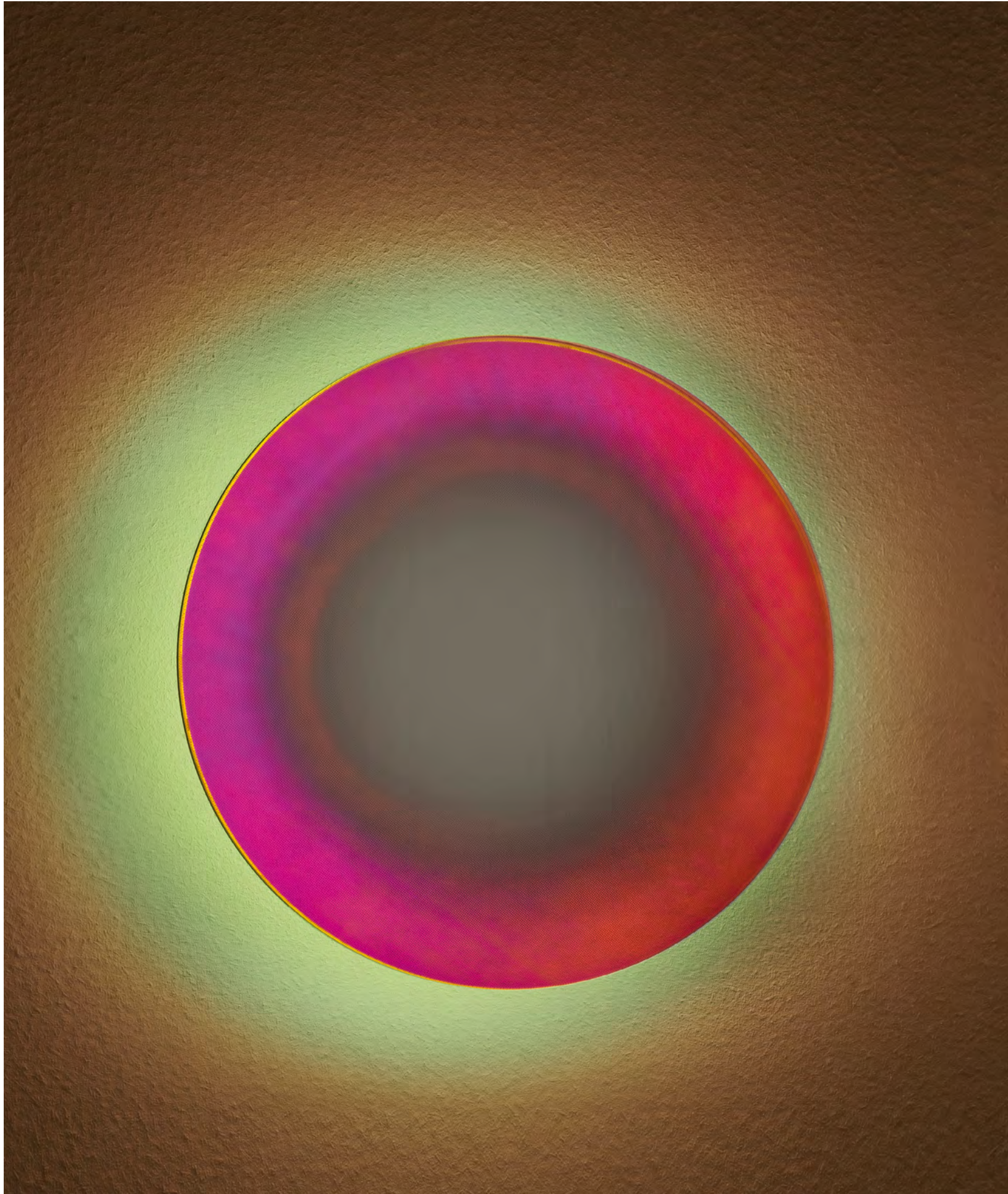



INDEX ←





Specchio di forma rettangolare con una cornice policroma caratterizzata da una texture di segni a punta di pennello. Disponibile con doppi attacchi orizzontali e verticali.

Dimensioni: **SDP01** L 70 H 100

Rectangular-shaped mirror with a frame characterized by a texture of polychrome paint strokes. Available with double vertical and horizontal fixture.



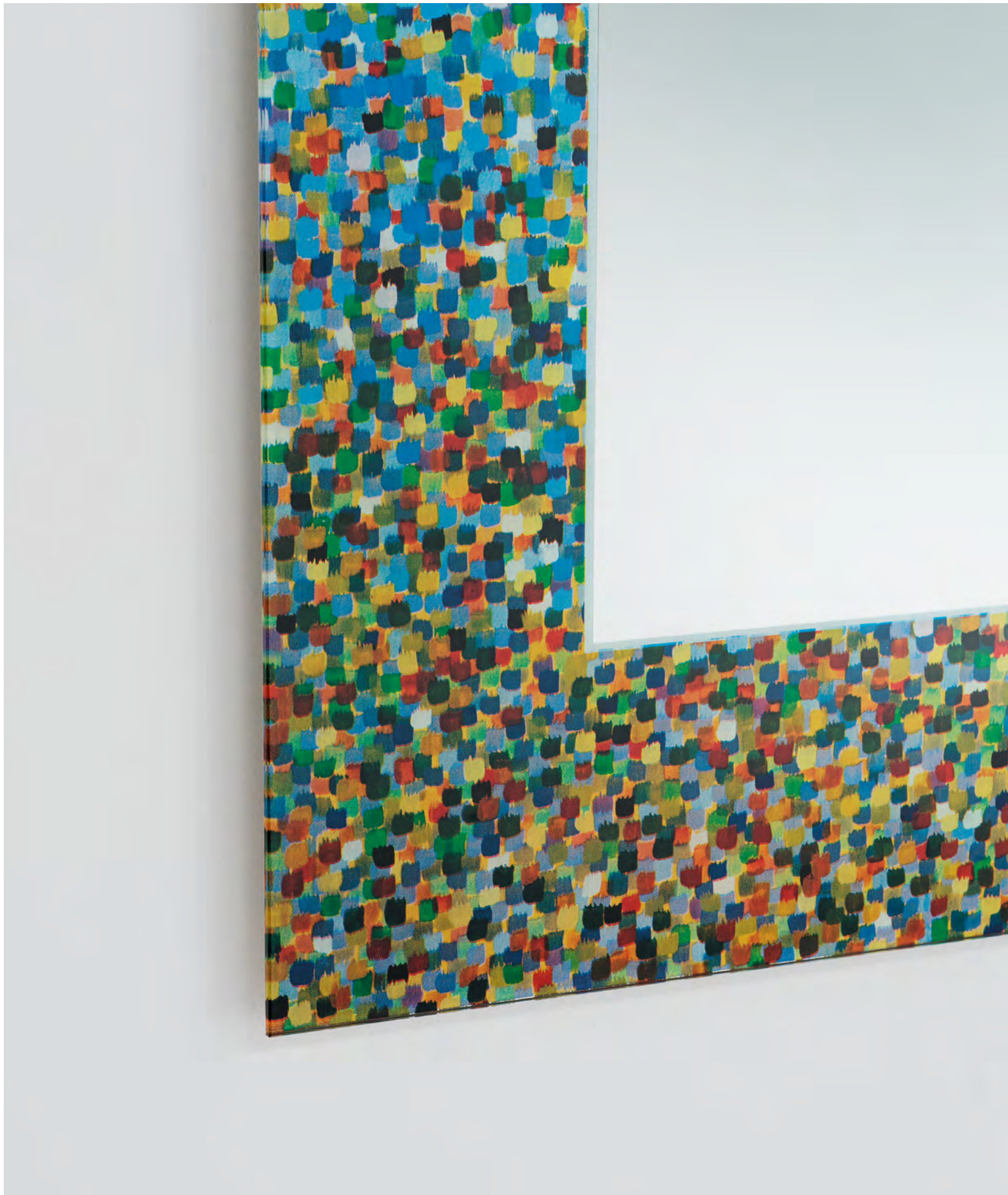



INDEX ←





Riedizione di uno storico specchio disegnato da Cinzia Ruggeri per Glas Italia nel 1989. Spizzo è uno specchio sagomato, disponibile in due formati e decorato con un delicato inserto di pizzo specchiante.

Dimensioni:

SP01 L 70 P 6 H 150

SP02 L 90 P 6 H 90

Re-launch of a historic mirror designed by Cinzia Ruggeri for Glas Italia in 1989. Spizzo is a shaped mirror, available in two sizes and decorated with a delicate mirrored lace insert.







INDEX ←





Specchio di grande magnificenza con cornice in cristallo di Murano, ottenuta grazie a complesse e raffinate lavorazioni manuali, che rendono ogni pezzo unico ed irripetibile. La cornice è composta da diversi elementi, che vengono fissati ad un pannello appeso a parete, sul quale viene poi applicato uno specchio bisellato da 5 mm. Disponibile anche con un impianto di illuminazione a Led, che enfatizza e valorizza la cornice.

Dimensioni:

STU01 L 210 P 20 H 230

STU02 L 150 P 20 H 150

A truly magnificent mirror with Murano glass frame, achieved through a complex and refined hand-made production process, making each piece unique and unrepeatable. The frame is composed of various elements which are fixed to a wall hanging structure upon which a 5 mm thick chamfered mirror is then applied. Available also with a Led lighting system, which enhances and exalts the frame.







INDEX ←





Specchiera da terra con specchio di cristallo, due lampade e console in legno di pero e impiallacciatura Alpi. Il basamento è in legno verniciato all'anilina. Ogni pezzo è identificato da una numerazione progressiva.

Dimensioni: **SYB** L 160 P 49 H 198

Mirror unit with crystal mirror, two lamps and console table made of pearwood and Alpi veneer. The base is in anilinevarnished wood. Every piece is identified by a progressive numbering.



COMPLEMENTI / COMPLEMENTS





Vasi composti da un involucro a forma di parallelepipedo, realizzato in cristallo fumè, incollato a 45°, e da una scultura in ceramica di forma organica, sostenuta e contenuta al suo interno. L'elemento in ceramica, disponibile nelle finiture bianco opaco o laccato platino, è cavo e può contenere acqua. Disponibile in due differenti forme e misure.



Dimensioni:

ANG01 L 20 P 20 H 60
Angelo

ANG02 L 60 P 23 H 45
Angela



A series of vases composed of a parallelepiped shaped case, realized in smoked glass, glued 45°, and an organic shaped ceramic sculpture, supported and contained in its inside. The ceramic element, available in the finishes opaque white or platinum lacquered, is hollow and can contain water. Available in two different shapes and sizes.





INDEX ←



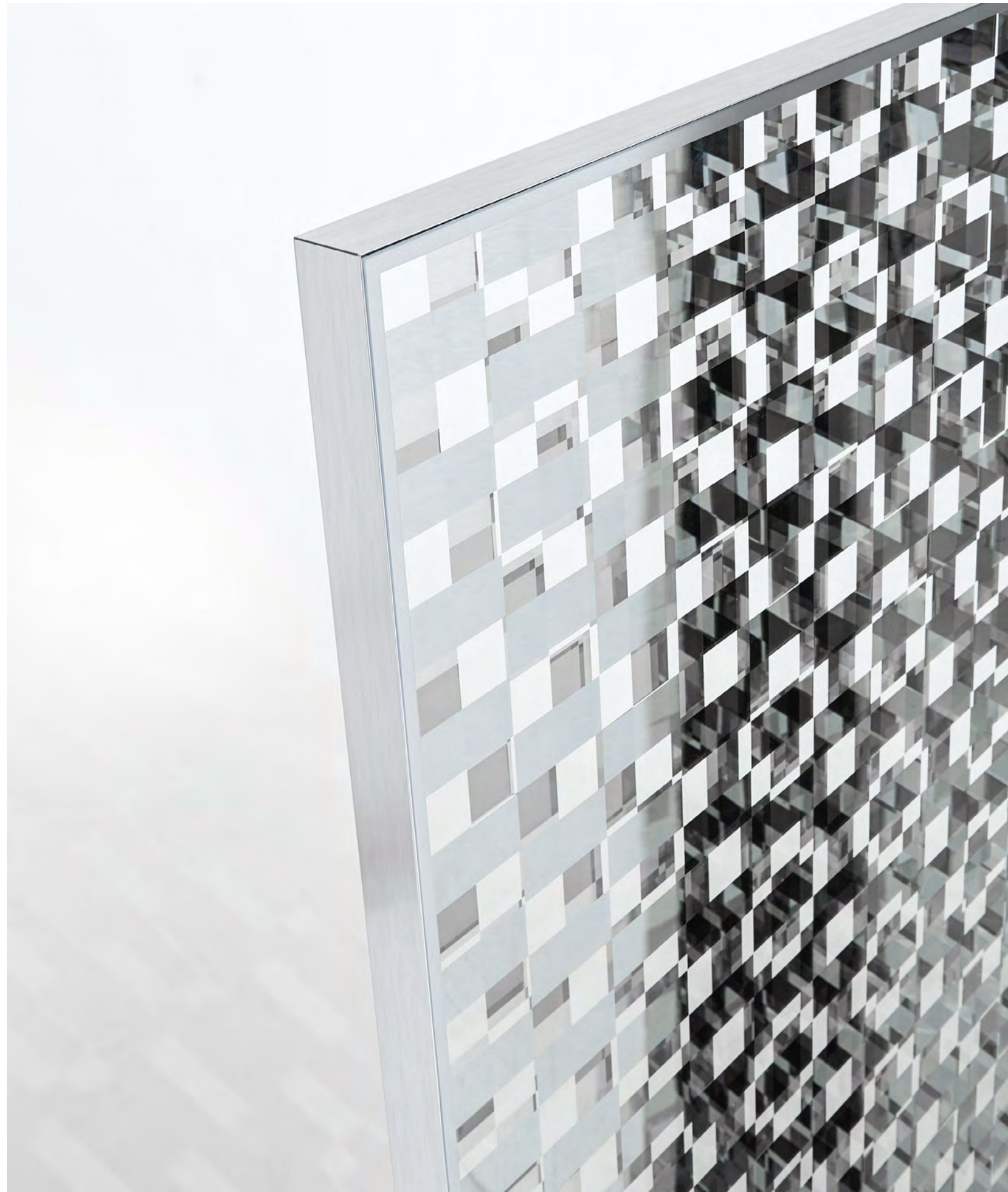

Paravento in cristallo trasparente extralight temperato, con uno speciale decoro a scacchi rettangolari in specchio bifacciale. Due cristalli, con scacchiere orientate perpendicolarmente, sono applicati sulle due facce di una cornice d'alluminio brillantato spazzolato, rimanendo separati da un interstizio di alcuni centimetri. In tal modo si crea un gioco di specchiature, coperture e trasparenze che ingannano l'osservatore, dissimulando e confondendo gli oggetti riflessi con quelli schermati, e viceversa. Il paravento è composto da pannelli modulari incernierati tra di loro.

Dimensioni:

FRA04 L 87 P 5 H 189
singolo pannello paravento / single screen panel

Screen with a special checked decoration on double-sided mirror. Two perpendicularly checked crystals are applied to a double-sided frame in polished brushed aluminum, separated by a gap of a few centimetres. These objects create a game of mirrored reflections, coverings and transparencies that deceive the observer, dissimulating and confusing the objects reflected from the ones screened and vice versa. The screen is made of hinged modular panels.







■ ← INDEX





Paravento in specchio curvato 6 mm, disponibile in due diverse misure. Gli angoli sono smussati, mentre i lati verticali e quello superiore sono impreziositi da un bordo con una marcata bisellatura. Sul retro è applicata una pellicola di sicurezza anti-frantumazione di colore argento.

Dimensioni: **PRP01** L 120 P 40 H 180

Screen in curved mirror 6 mm thick, available in two different sizes. The corners are smoothed, whilst the vertical and the upper side are embellished with a large chamfer. On the reverse there is a safety anticrushing film in silver colour.







INDEX ←





Paravento componibile con pannelli incernierati, realizzati in cristallo Flutes stratificato e temperato disponibile in finitura neutra o nella gamma dei "Cristalli trasparenti colorati". E' disponibile anche uno specchio posizionabile ad una estremità della composizione. Le venature del cristallo sono orizzontali o verticali, a seconda del formato del pannello, le cerniere sono in ottone cromato antracite. La libertà compositiva di queste pannellature, con finitura traslucida, permette di realizzare strutture che schermano, separano e al contempo creano isole di intimità e riservatezza, filtrando e restituendo la luce in maniera poetica e meravigliosamente surreale.



Dimensioni:

RAY01	L 110	H 140	RAY06	L 60	H 200
RAY02	L 65	H 140	RAY07	L 100	H 140
RAY03	L 80	H 230	RAY08	L 90	H 140
RAY04	L 65	H 200	RAY09	L 50	H 180
RAY05	L 36	H 90	RAY10	L 27	H 80
	<i>specchio / mirror</i>			<i>specchio / mirror</i>	



Modular screen with hinged panels in laminated and tempered Flutes glass available in neutral or "transparent coloured glass" range finishes. It is available also a mirror to be placed at the extremity of the composition. The glass veining is horizontal or vertical according to the size of the panel and the hinges are in anthracite chromed brass. The freedom of use with these panels with translucent finish allows the creation of screening and separating structures and at the same time to obtain privacy areas, filtering the light and returning it in a poetic and marvelously surreal way.







INDEX



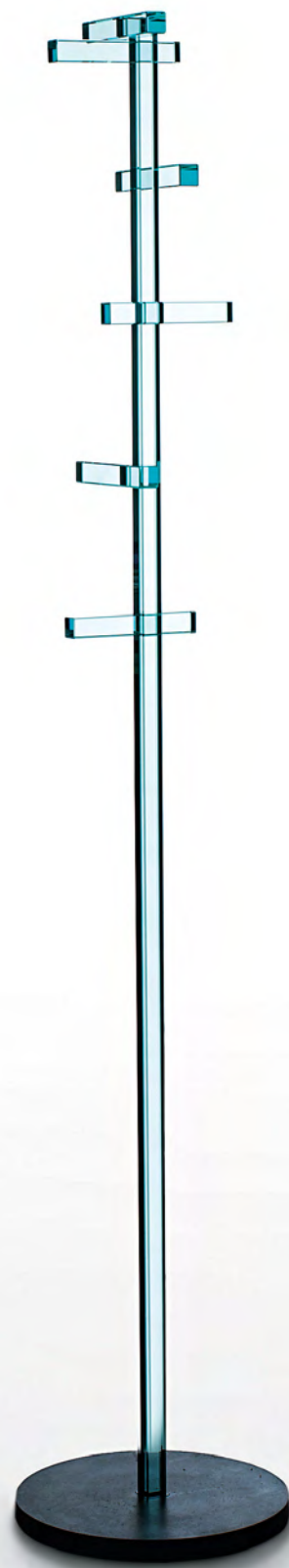

Porta abiti a piantana di grande leggerezza e rigore formale. Lo stelo, realizzato incollando barre quadre di cristallo trasparente da 24x24 mm, è fissato mediante un sistema ad incastro ad una base in metallo verniciato nero opaco di grosso spessore. Nonostante l'estrema esilità delle sezioni, il cristallo, grazie ad uno speciale trattamento di tempera, assume un'incredibile resistenza ai carichi.

Dimensioni: **TEL01** \varnothing 30 H 164

Coat stand with great lightness and formal accuracy. The stem is achieved by gluing square bars of 24x24 mm thick transparent glass fixed by means of a joint system to a base made of very thick black opaque varnished metal. Despite the extreme thinness of the sections, the crystal glass has a high load resistance thanks to a special tempering treatment.





INDEX ←





Collezione di vasi in cristallo borosilicato con forme cilindriche e coniche deformate in maniera casuale ed irregolare, in modo che ogni pezzo risulti essere diverso dall'altro e non riproducibile. Queste lavorazioni manuali rendono quindi ogni vaso unico e speciale.

Dimensioni:

TRN01 ø 18 H 30

TRN02 ø 22 H 27

TRN03 ø 22 H 26

Collection of vases in borosilicate glass with cylindrical and conical shapes, deformed in a casual and irregular manner so that each piece is a one-off and cannot be reproduced. This hand-made production makes each vase unique and special.







■ ← INDEX





Vasi cilindrici in cristallo borosilicato trasparente. Grazie ad una complessa e raffinata lavorazione di soffiatura, all'interno del cilindro viene creata una concavità che presenta soluzione di continuità con l'esterno. Disponibile in due altezze differenti.



Dimensioni: **TUT01** ø 15 H 37,5 **TUT02** ø 15 H 50



Cylindrical vases in borosilicate transparent glass. Thanks to a complex and refined blowing manufacturing, a concavity, presenting continuity of solution with the outside, is created in the inside of the cylinder. Available in two different heights.



MENSOLE / SHELVES





Serie di mensole con schienale in specchio e doppio ripiano in cristallo trasparente extralight 8 mm temperato. Questa mensola, dalla leggerezza e purezza formale, oltre a sorreggere e contenere si caratterizza per la sua funzione specchiante.

Dimensioni:

EVE01 L 80 P 24 H 31

EVE02 L 120 P 24 H 31

EVE03 L 150 P 24 H 31

EVE04 L 180 P 24 H 31

A series of shelves with mirrored back and transparent extralight double plate 8 mm thick tempered. In addition to sustaining and containing, this shelf is characterised by its formal purity and lightness and as well by its reflecting function.







← INDEX



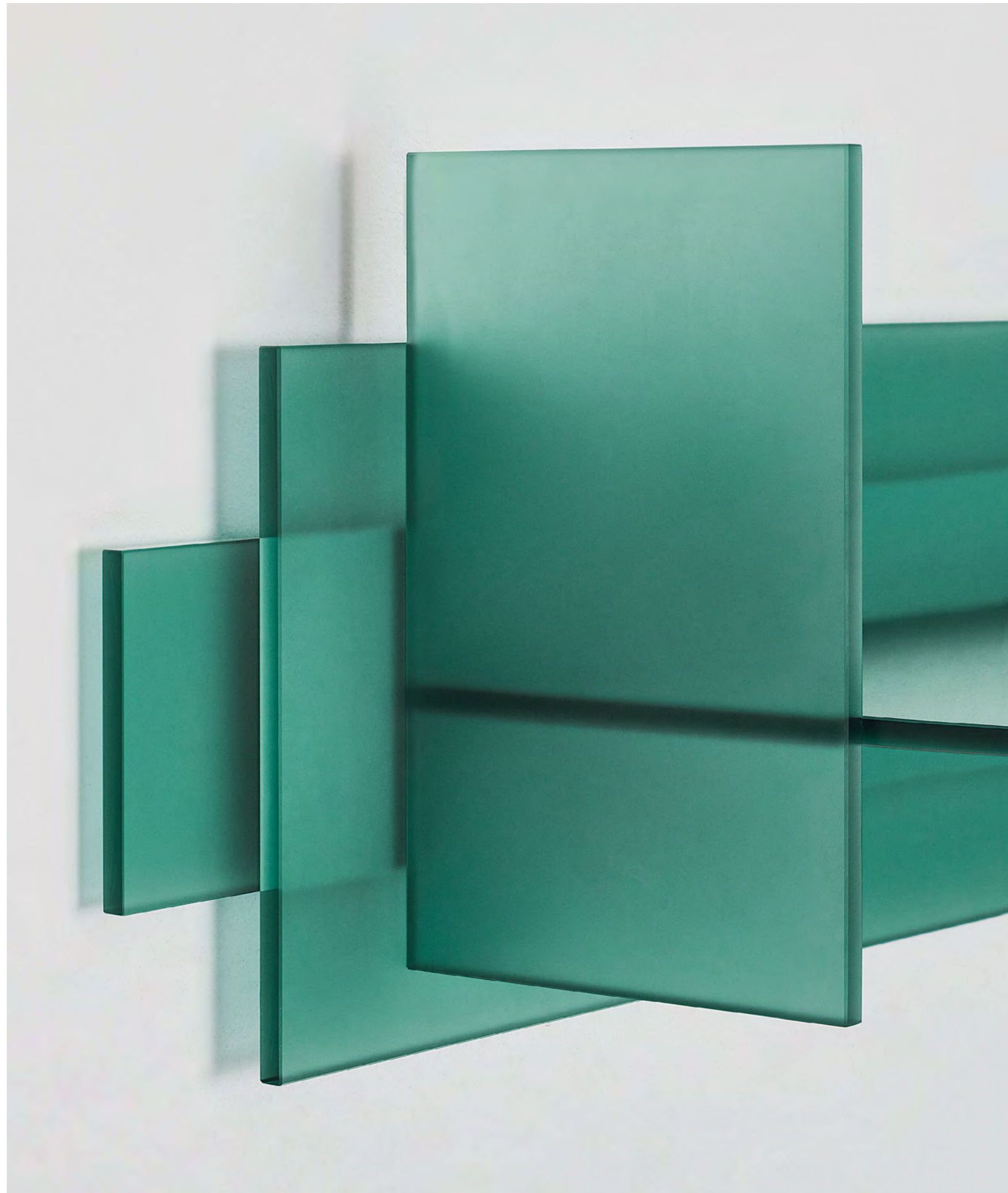

Collezione di arredi composta da mensole, console e tavolo basso, completamente realizzata in uno speciale cristallo verde acidato bifacciale da 10 mm temperato, o in cristallo extralight acidato bifacciale da 10 mm temperato. Ogni articolo è una composizione di lastre di cristallo sovrapposte che, giuntate tra di loro in purezza grazie all'incollaggio UV, danno forma a raffinati arredi scultorei dall'assoluto rigore formale. Le mensole possono essere appese capovolte.



Dimensioni:

KAZ01 L 95 P 28 H 31,5
KAZ02 L 94 P 28 H 31,5
KAZ03 L 93 P 28 H 31,5

KAZ04 L 54 P 28 H 31,5
KAZ05 L 54 P 28 H 31,5
KAZ06 L 173 P 28 H 31,5



Collection of furniture consisting of shelves, console and low table, completely made of a special 10 mm tempered double-sided green acid-etched glass, or, in 10 mm tempered double-sided acid-etched extralight glass. Each item is a composition of interlocked and overlapping glass sheets which, through a special UV bonding method, give shape to pure and refined sculptural furnishing elements characterized by a rigorous form. The shelves can be hung upside down.

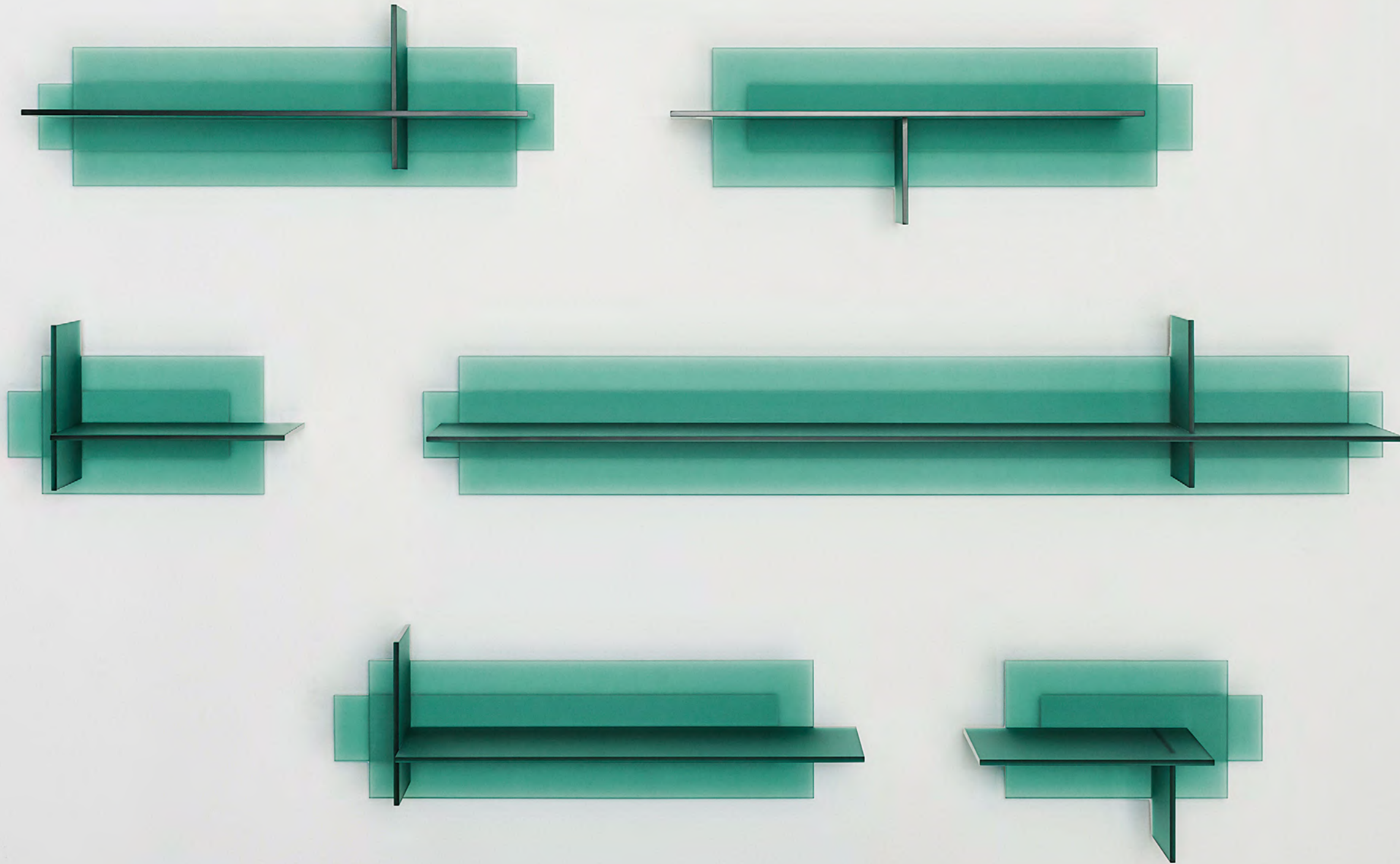

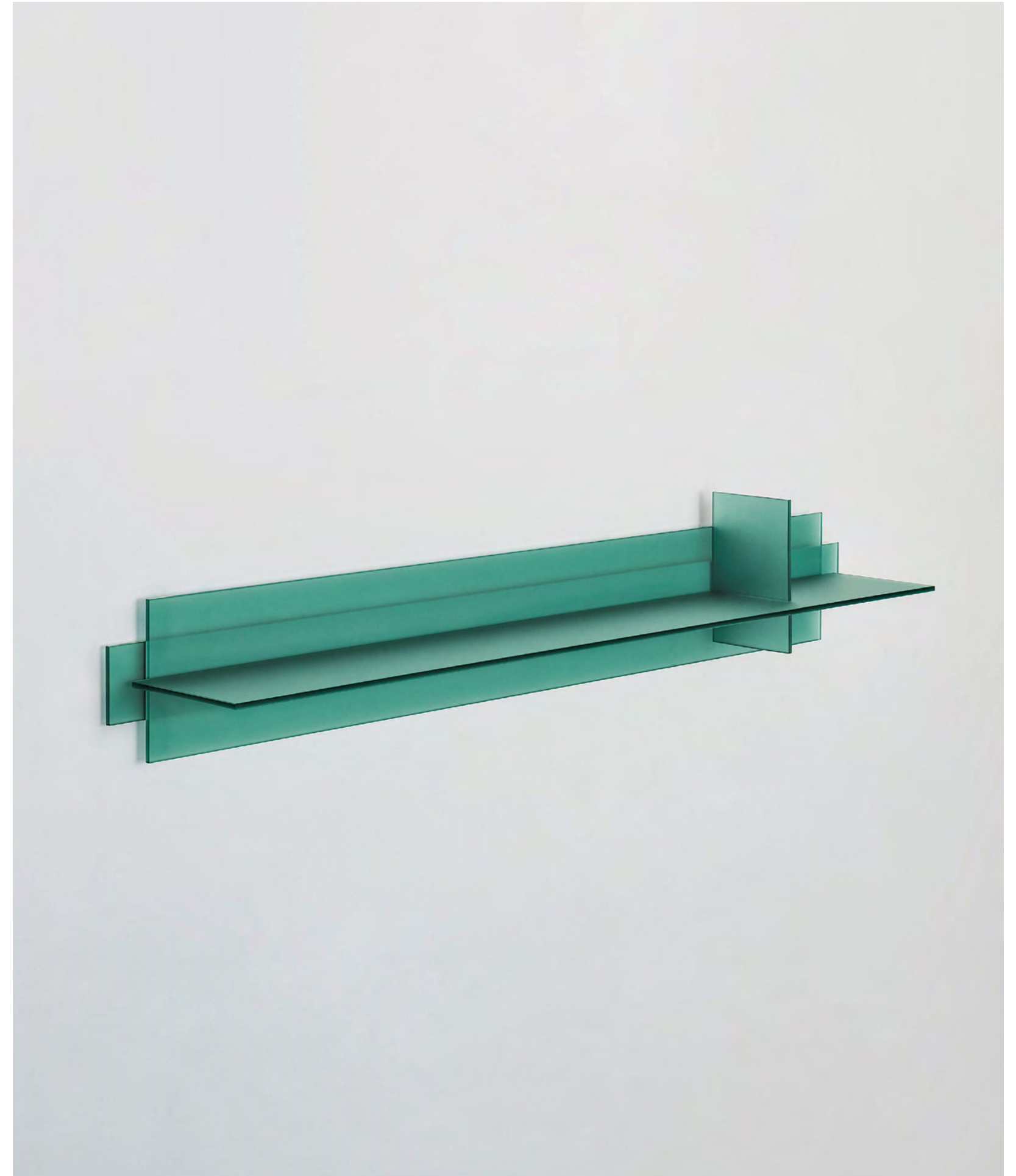



INDEX ←





Collezione di mensole realizzate incollando lastre di cristallo temperato 6 mm, molato a 45°, opaco di colore bianco, con all'interno un impianto di luce a led con o senza dimmer. Per l'accensione e regolazione dell'intensità va prevista una pulsantiera a parete.



Dimensioni:

MLI01 L 160 P 24 H 11
(35W)
MLI02 L 130 P 24 H 11
(28W)

MLI03 L 80 P 24 H 11
(14W)



Collection of shelves made of glued 6 mm thick tempered glass plates with 45° chamfered edge. The glass plates are opaque white. The shelf is provided with a LED light equipment, with or without dimmer. For the lighting and intensity regulation it is necessary a wall push button panel.





INDEX ←





Mensole realizzate con due cristalli temperati laccati opachi o laccati lucidi 8 mm incollati tra di loro e sorretti da un cuneo di metallo fissato a muro.

Finiture: cristalli laccati opachi / cristalli laccati lucidi

Dimensioni:

MON01 L 100 P 29 H 12

MON02 L 120 P 29 H 12

MON03 L 150 P 29 H 12

MON04 L 200 P 29 H 12

Shelves made of two tempered crystal plates 8 mm thick, opaque lacquered or glossy lacquered, glued together and supported by a steel wedge which allows the shelf to be hung.

Finishes: opaque lacquered glass / glossy lacquered glass





Disegni Tecnici e Finiture



INDEX ←



TAVOLI / TABLES

CONSOLLE / CONSOLES

SCRITTOI / DESKS



Alice
Jean-Marie Massaud

codice / code :
ALI01

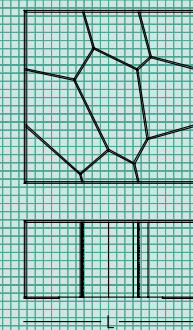

codice / code :
ALI02

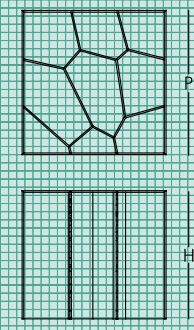

Atlantis *tavoli alti*
Lorenzo Arosio

codice / code :
TAA03/07

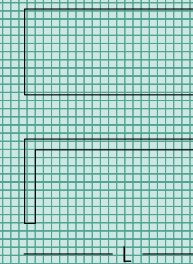

codice / code :
TAA02/05

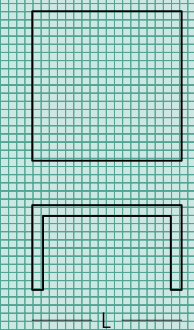

Atlantis *tavoli bassi*
Lorenzo Arosio

codice / code :
TAT05/06

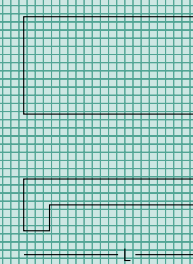

codice / code :
TAT07/08

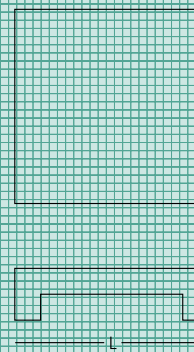

Babar
Patricia Urquiola

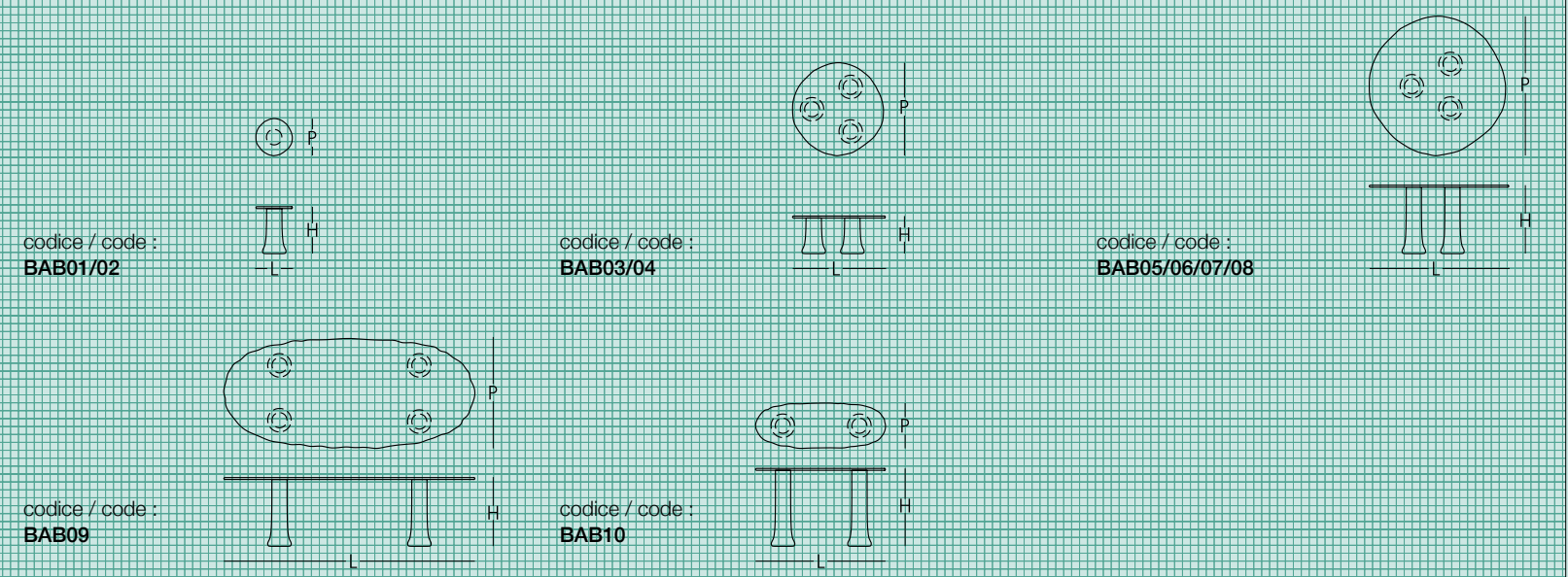

codice / code :
BAB01/02

codice / code :
BAB03/04

codice / code :
BAB05/06/07/08

codice / code :
BAB09

codice / code :
BAB10

Bisel
Patricia Urquiola

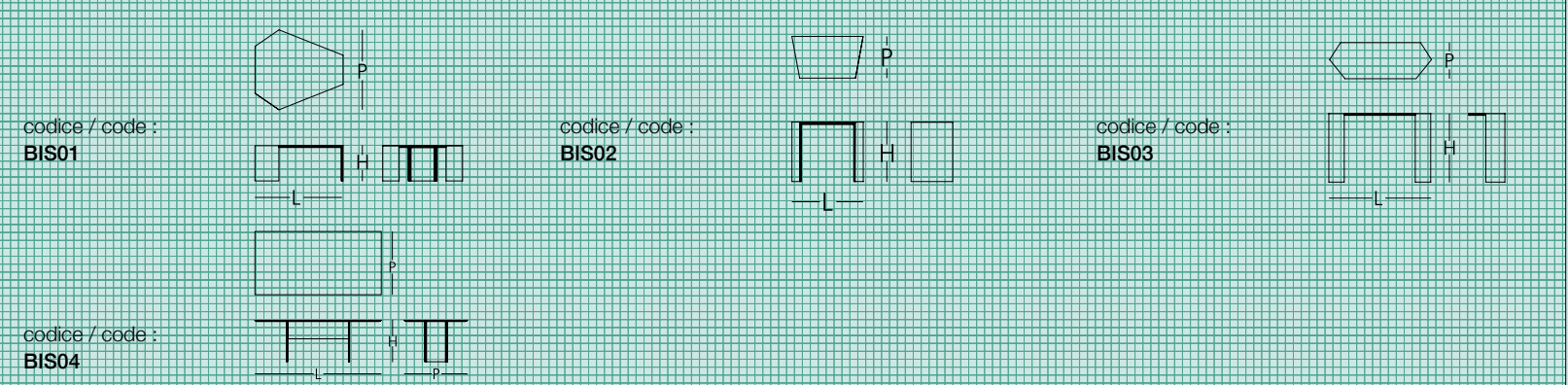

codice / code :
BIS01

codice / code :
BIS02

codice / code :
BIS03

codice / code :
BIS04

BoxInBox
Philippe Starck

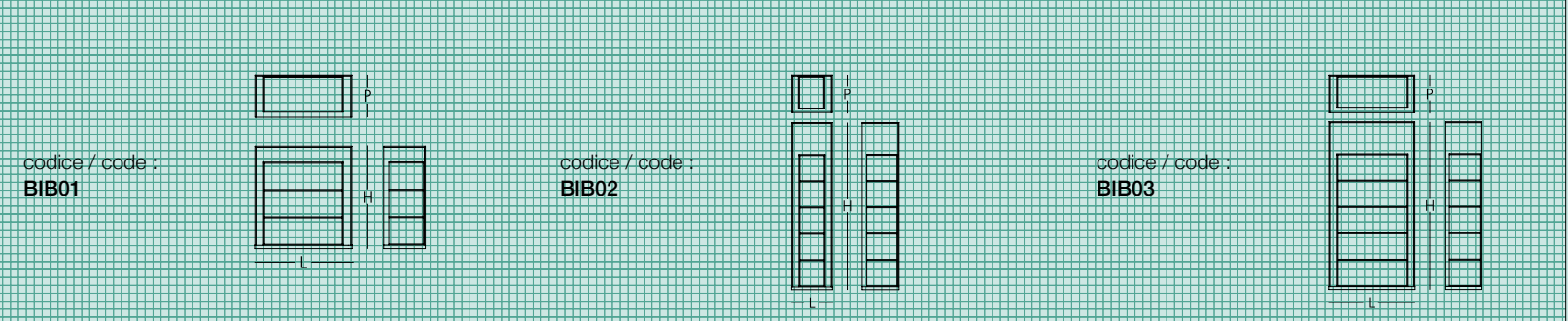

codice / code :
BIB01

codice / code :
BIB02

codice / code :
BIB03

BoxInBox
Philippe Starck

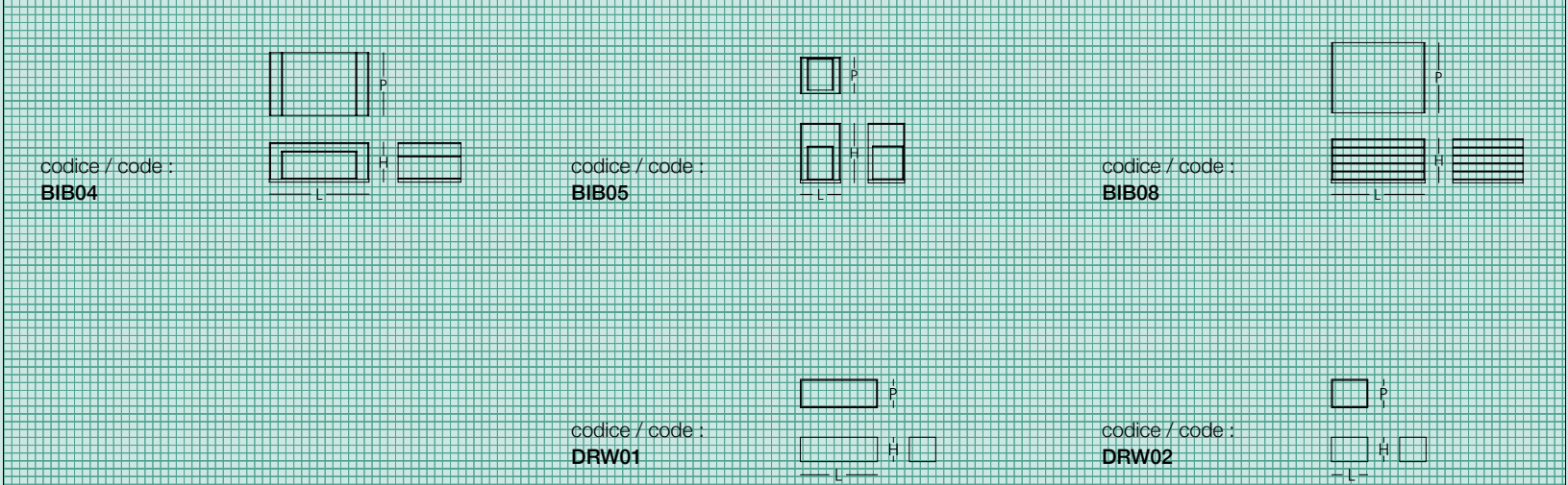

codice / code :
BIB04

codice / code :
BIB05

codice / code :
BIB08

codice / code :
DRW01

codice / code :
DRW02

Calice
Piero Lissoni

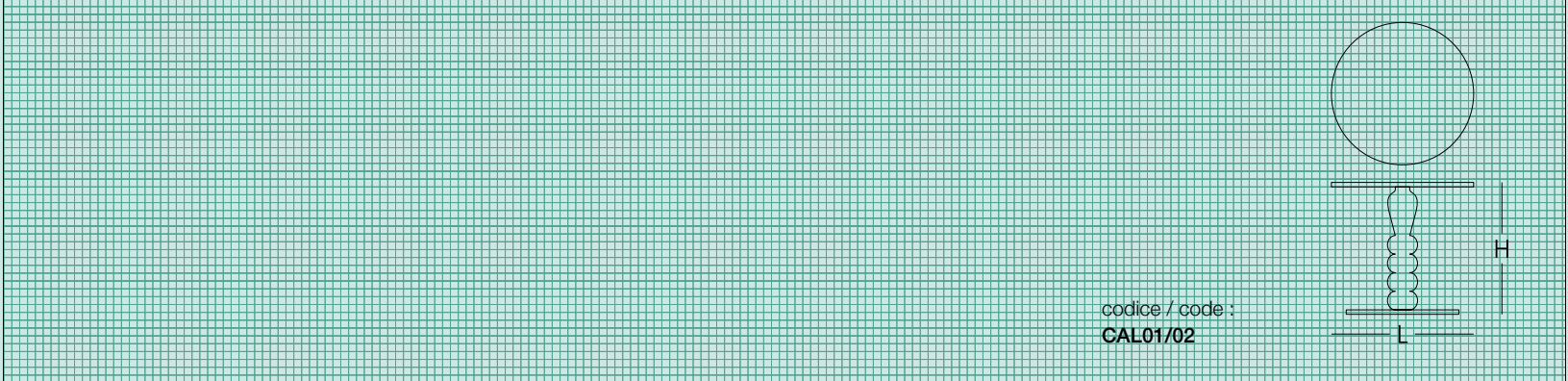

codice / code :
CAL01/02

Collector
Edward Barber & Jay Osgerby

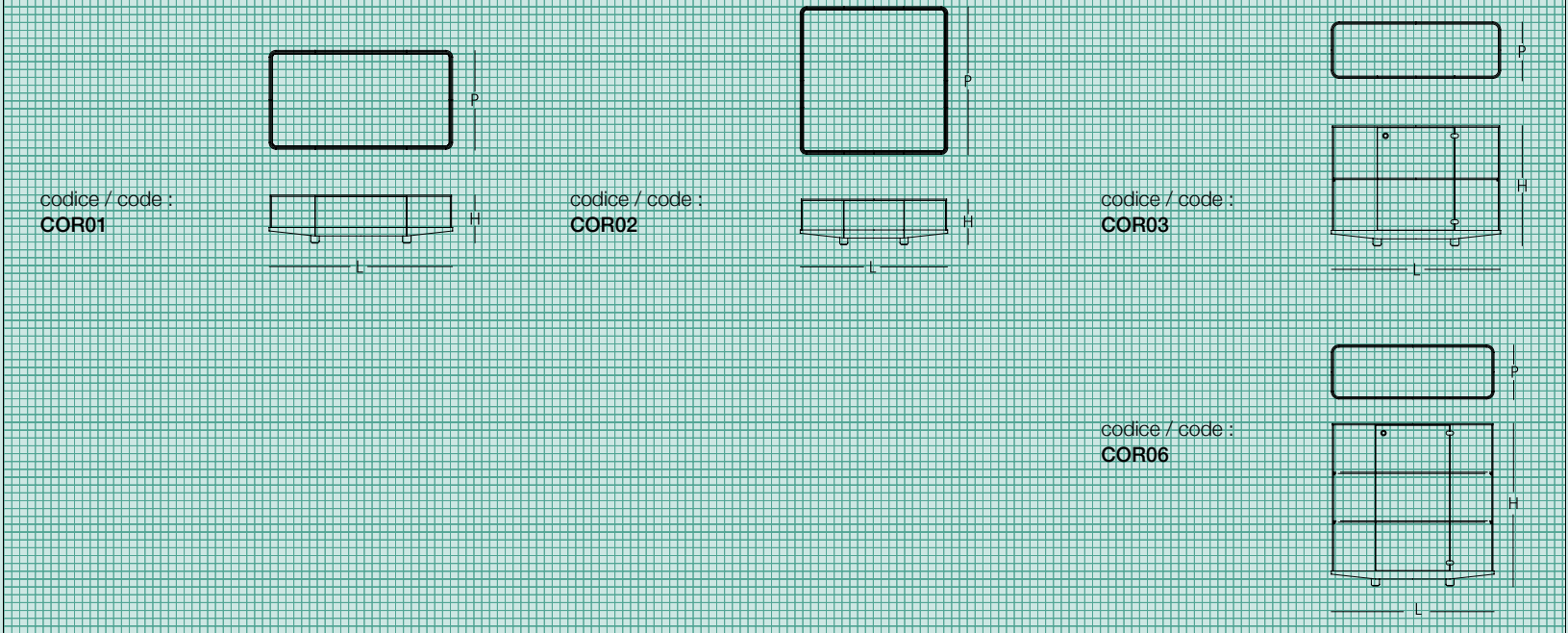

codice / code :
COR01

codice / code :
COR02

codice / code :
COR03

codice / code :
COR06

Compression
Philippe Starck

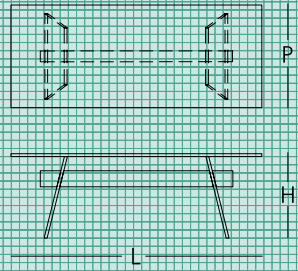

codice / code :
COMP01/02/03
/04/05/06

Crack
Johanna Crawunder

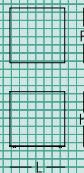

codice / code :
CRA01/02



codice / code :
CRA03

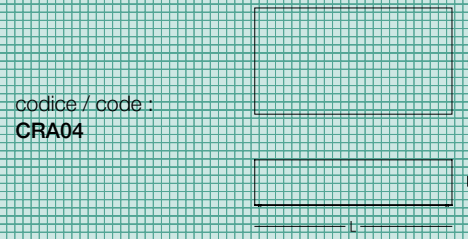

codice / code :
CRA04

Crossing
Patricia Urquiola

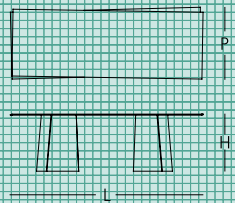

codice / code :
CRO01/02

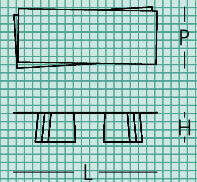

codice / code :
CRO03

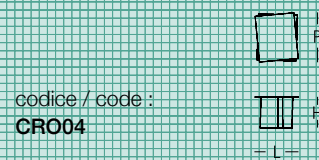

codice / code :
CRO04

Deep Sea
Nendo

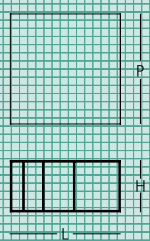

codice / code :
DEE01

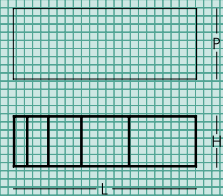

codice / code :
DEE02

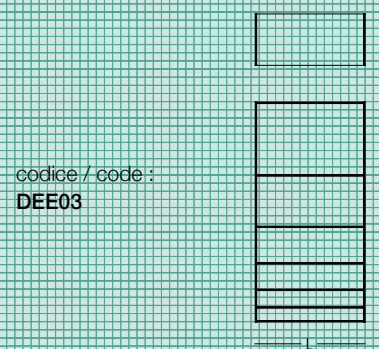

codice / code :
DEE03

Diapositive
Ronan & Erwan Bouroullec

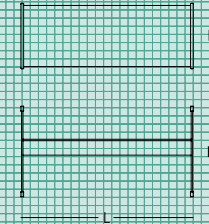

codice / code :
DIA01

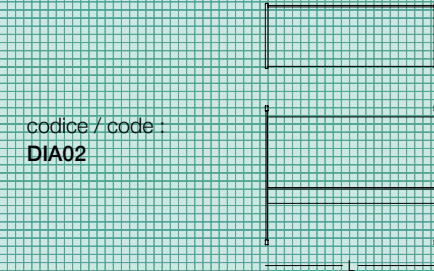

codice / code :
DIA02

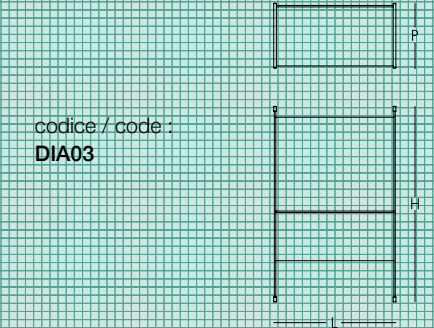

codice / code :
DIA03

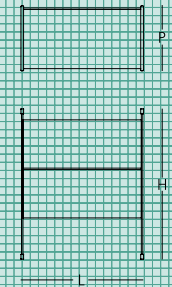

codice / code :
DIA04

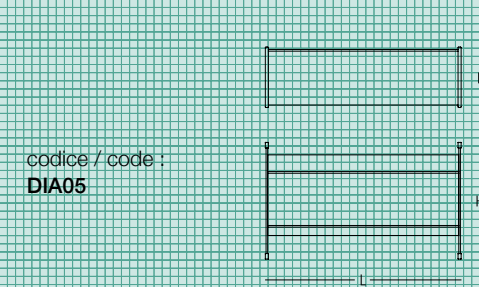

codice / code :
DIA05

Doble
Patricia Urquiola

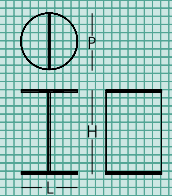

codice / code :
DOL01

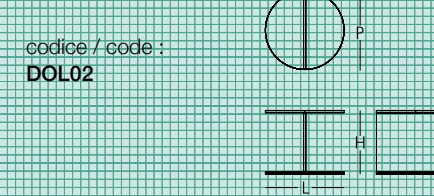

codice / code :
DOL02

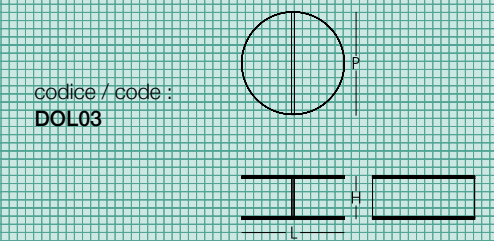

codice / code :
DOL03

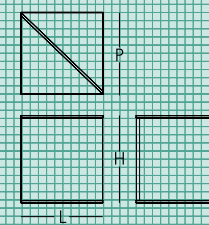

codice / code :
DOL04

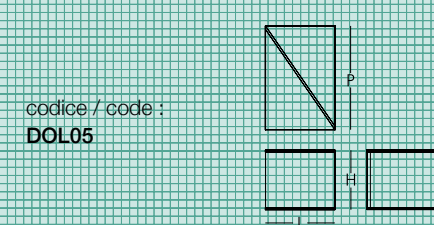

codice / code :
DOL05

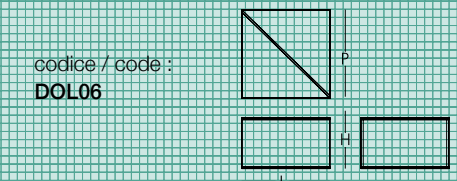

codice / code :
DOL06

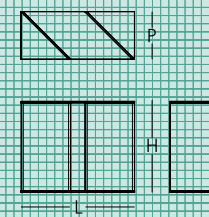

codice / code :
DOL07

Donald *tavoli alti*
Philippe Starck

codice / code :
DOA01/02/03

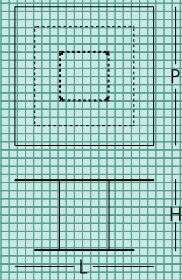

codice / code :
DOA04/05/06

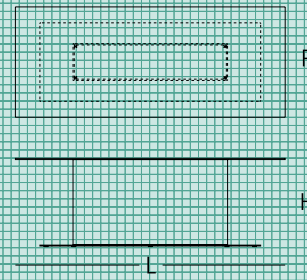

Donald *tavoli bassi*
Philippe Starck

codice / code :
DOB01

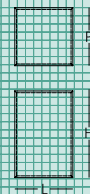

codice / code :
DOB02

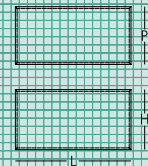

codice / code :
DOB03

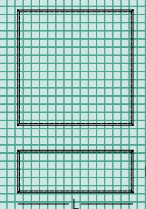

Don Cavalletto
Jean-Marie Massaud

codice / code :
DOC01/02/03/04/05

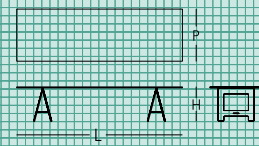

Don Gerrit
Jean-Marie Massaud

codice / code :
DON

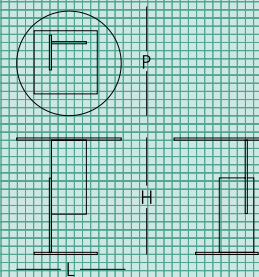

Float
Patrik Norguet

codice / code :
FLO02/07

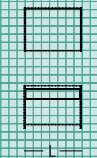

codice / code :
FLO04

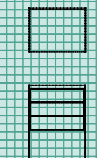

codice / code :
FLO05

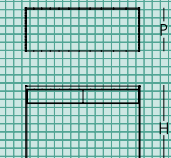

codice / code :
FLO06

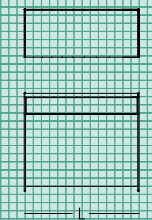

codice / code :
FLO08

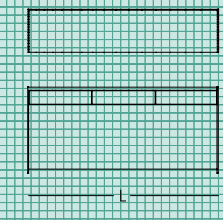

Folio
Yabu Pushelberg

codice / code :
FOL01

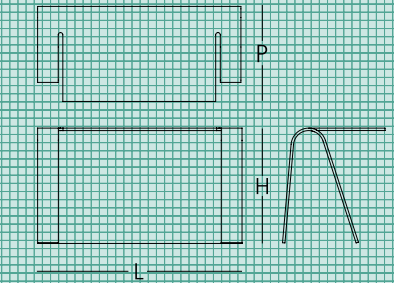

Fountain
Tokujin Yoshioka

codice / code :
FOU01

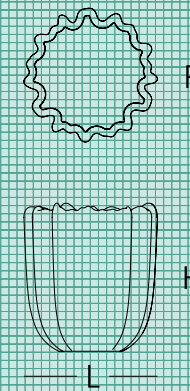

codice / code :
FOU02

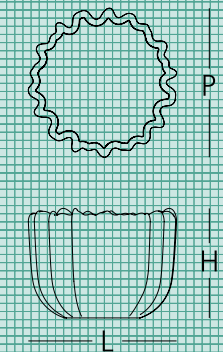

codice / code :
FOU03

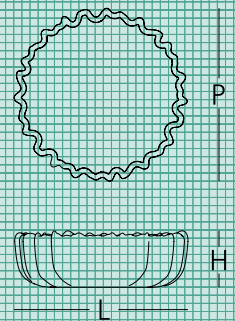

codice / code :
FOU04

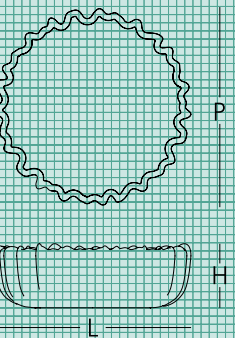

Funghetti
Piero Lissoni

codice / code :
TFU01/03

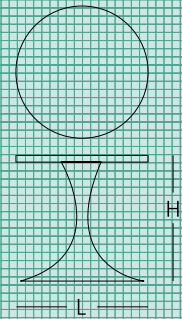

Glass Table (1976)
Shiro Kuramata

codice / code :
KUT

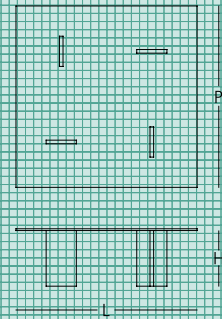

Harold and Maude
Carlo Tamborini

codice / code :
HAR01/02

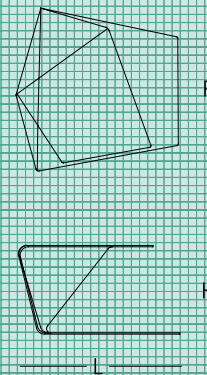

Hub
Piero Lissoni

codice / code :
HUB02/03/04/10/12

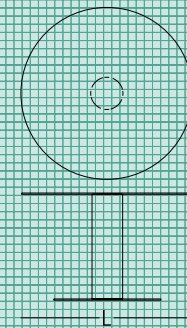

codice / code :
HUB07/08/09

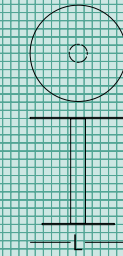

codice / code :
HUB06/11

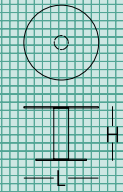

Hub Cut
Piero Lissoni

codice / code :
CUT01/02

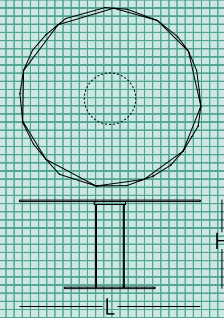

I-Beam
Jean-Marie Massaud

codice / code :
IBE02

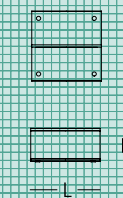

codice / code :
IBE03/04

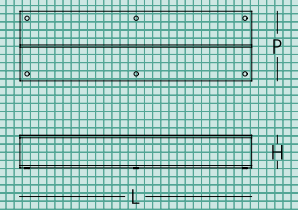

Illusion
Jean-Marie Massaud

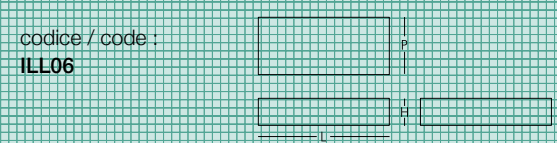
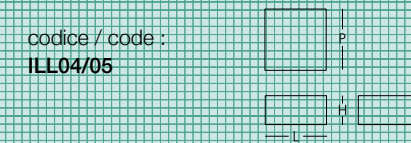
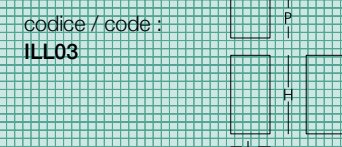
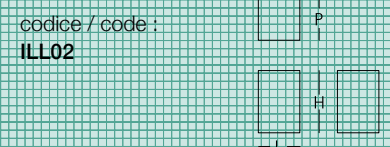
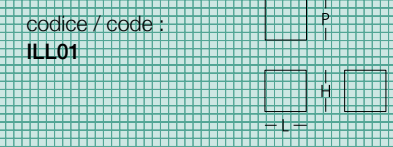

I Massi tavoli bassi
Claudio Silvestrin

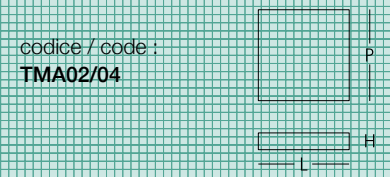
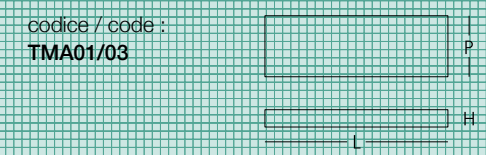

Kazimir
Michael Anastassiades

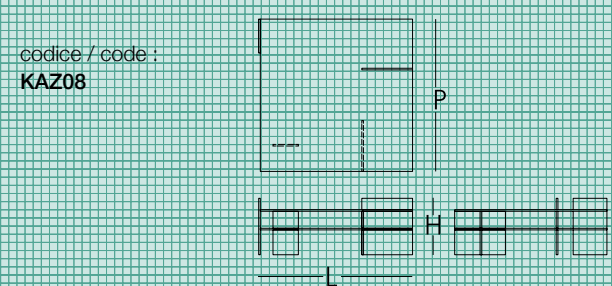
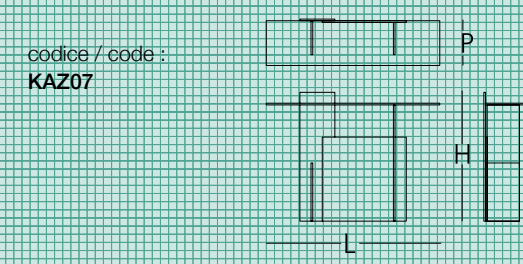

Kooh-I-Noor
Piero Lissoni

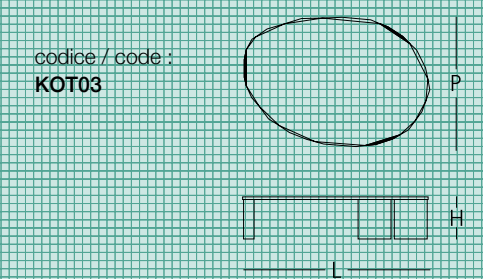

Lazy Hub
Piero Lissoni

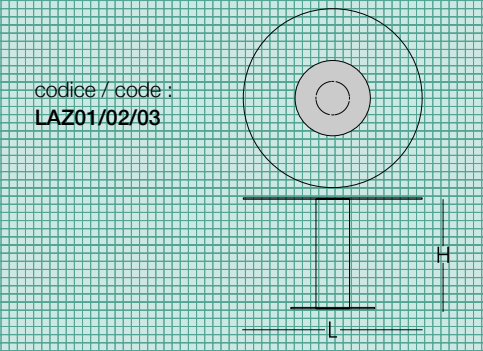

L.A. Sunset
Patricia Urquiola

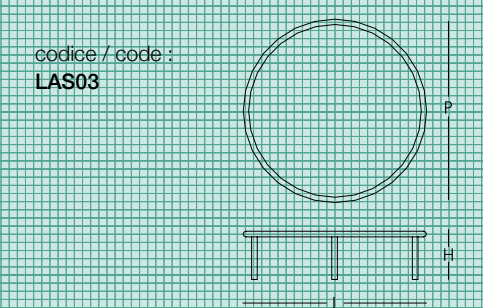
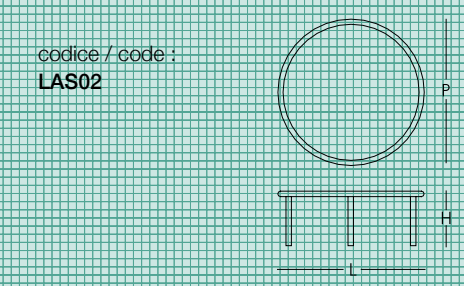
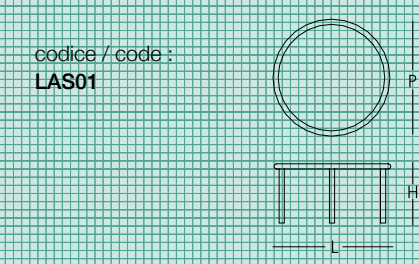

Liquefy

Patria Urquiola

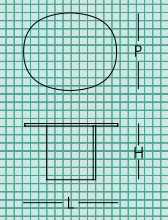
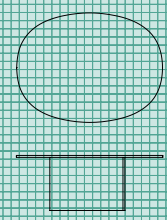
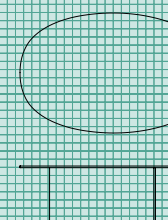
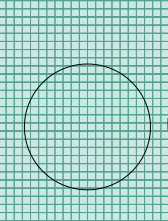
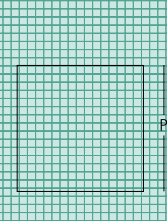
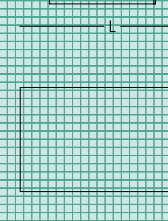
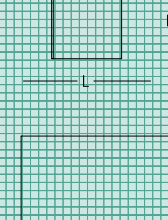
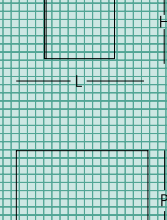
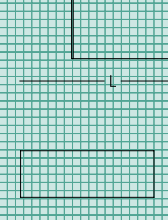
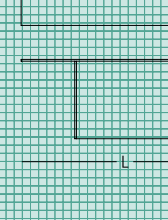
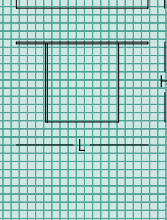
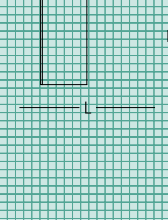
<p>codice / code : LIQ01</p> 	<p>codice / code : LIQ02/03</p> 	<p>codice / code : LIQ04</p> 
<p>codice / code : LIQ05</p> 	<p>codice / code : LIQ06</p> 	<p>codice / code : LIQ07</p> 
<p>codice / code : LIQ08</p> 	<p>codice / code : LIQ09</p> 	<p>codice / code : LIQ10</p> 
<p>codice / code : LIQ11</p> 	<p>codice / code : LIQ12</p> 	<p>codice / code : LIQ13</p> 

Mari Cristal

Philippe Starck

codice / code :
MAC01/02/03/04/05

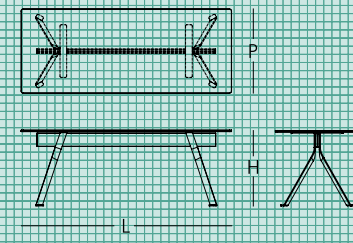

Metal

Piero Lissoni

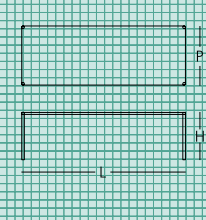
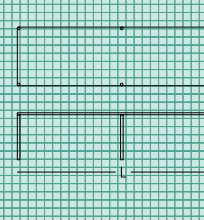
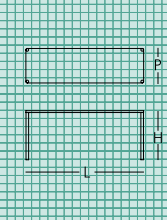
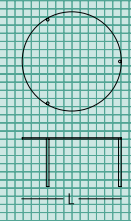
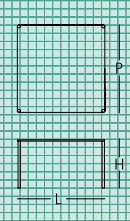
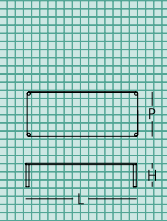
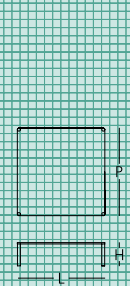
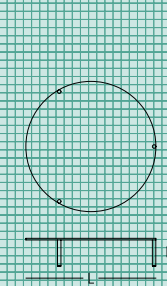
<p>codice / code : MET01/02/03/04/ 05/06/07/08</p> 	<p>codice / code : MET09/10/11/12/ 13/14/15/16</p> 	<p>codice / code : MET17/18/19/20/21</p> 
<p>codice / code : MET22/23/24/ 25/26/27</p> 	<p>codice / code : MET28/29/30/31/32</p> 	<p>codice / code : MET33/34/35/36</p> 
<p>codice / code : MET37/38/39/40/41</p> 	<p>codice / code : MET42/43/44/45/46</p> 	

Mirror Mirror

Jasper Morrison

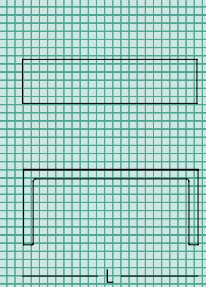
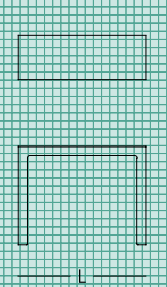
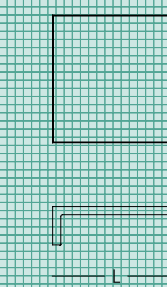
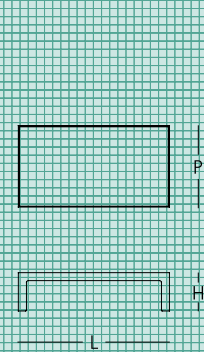
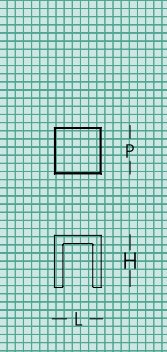
<p>codice / code : MIR03</p> 	<p>codice / code : MIR04</p> 	<p>codice / code : MIR05/06</p> 
<p>codice / code : MIR07</p> 	<p>codice / code : MIR08</p> 	

Nacre
Yabu Pushelberg

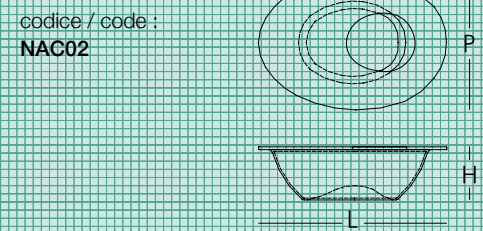
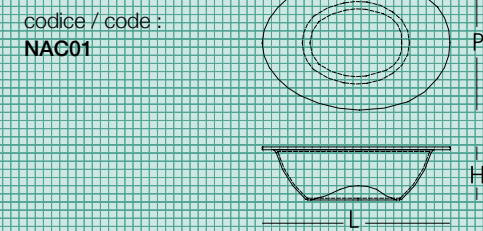

Nesting
Ronan & Erwan Bouroullec

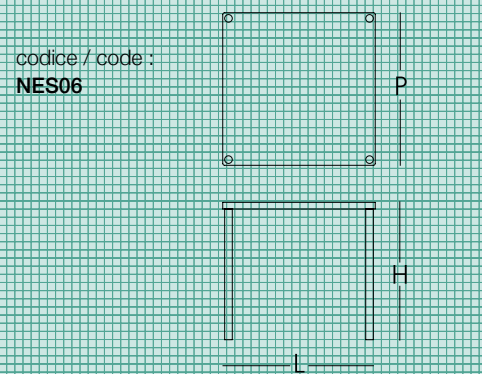
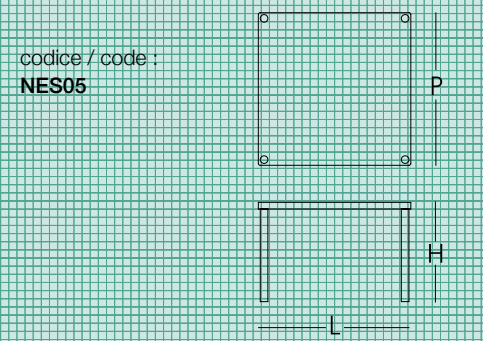
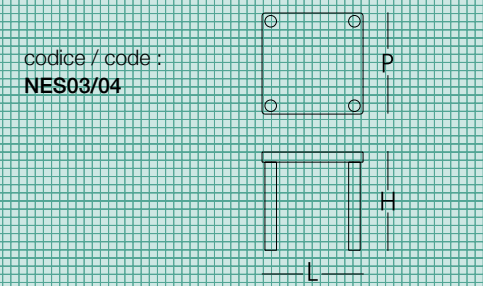

Ollie
Yabu Pushelberg

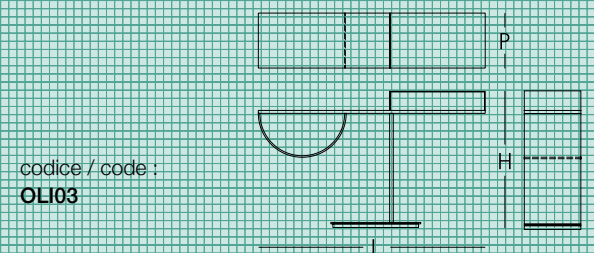
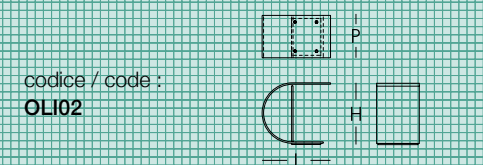

Oscar
Piero Lissoni

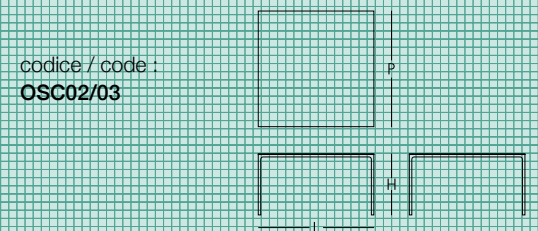
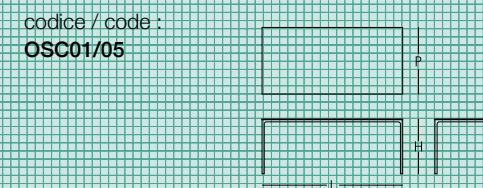

Pipeline
Piero Lissoni

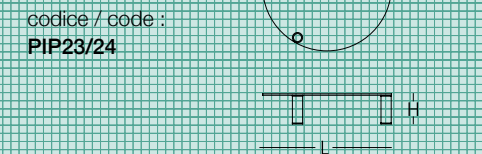
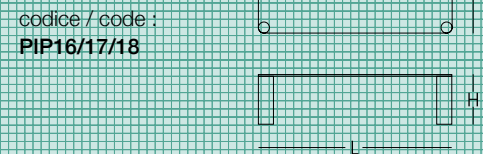
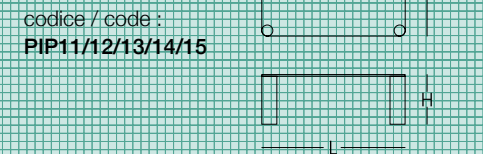
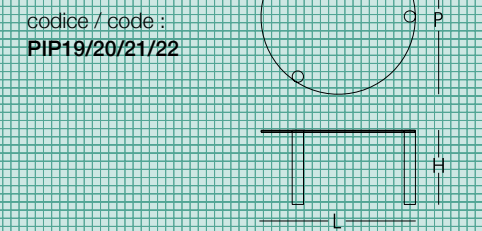
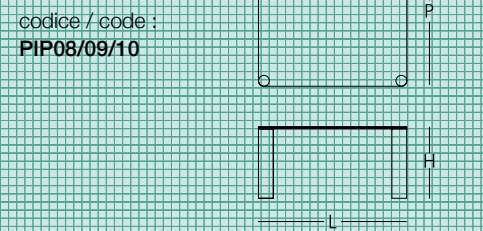
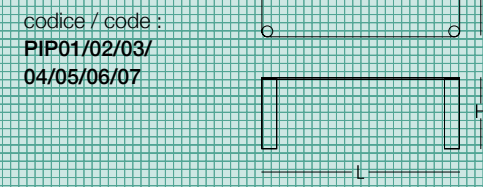

Pirandello
Jasper Morrison

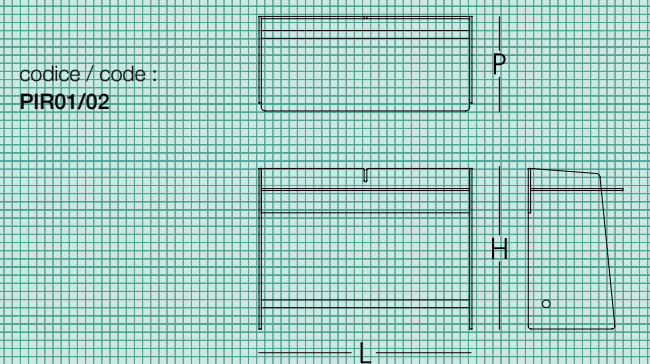

Plissè
Mario Bellini

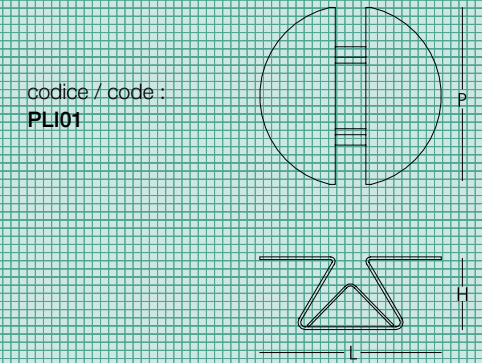

Post Modern
Piero Lissoni

codice / code :
**POS01/02/03/
04/05/06/07**

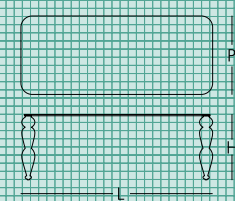

codice / code :
POS08/09/10

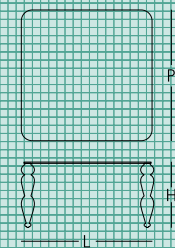

codice / code :
POS11/12/13/14/15

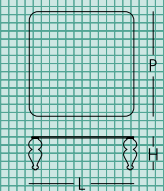

codice / code :
POS16/17/18

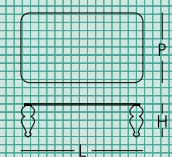

codice / code :
POS19

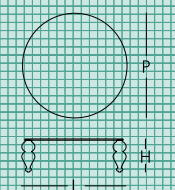

codice / code :
POS20/21/22/23

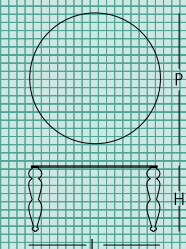

PRISM mirror table
Tokujin Yoshioka

codice / code :
PRT01

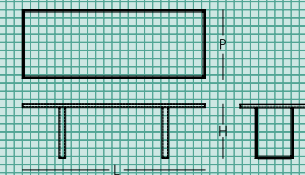

Ratio
Piero Lissoni

codice / code :
RAT01

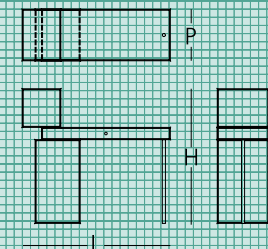

Remis
Patricia Urquiola

codice / code :
REM01

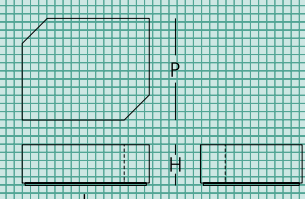

codice / code :
REM02

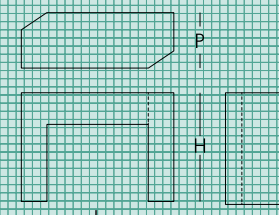

Robotin
Patricia Urquiola

codice / code :
ROB01

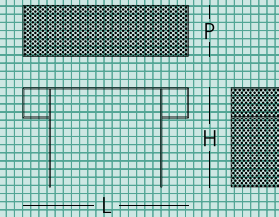

codice / code :
ROB03

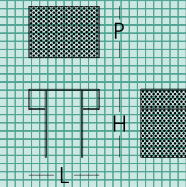

codice / code :
ROB04

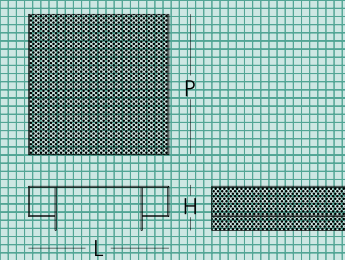

codice / code :
ROB05

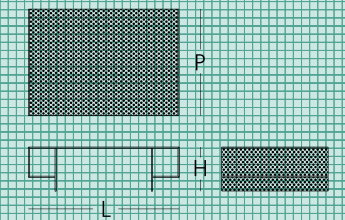

Seasons
Jean-Marie Massaud

codice / code :
SEA01

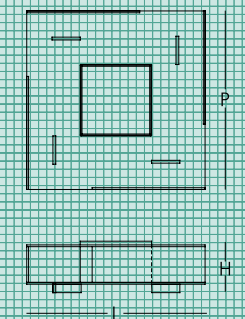

Shimmer
Patricia Urquiola

codice / code :
SHI01/02

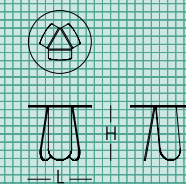

codice / code :
SHI03

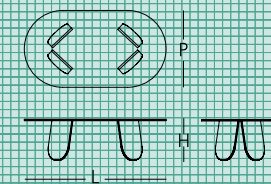

codice / code :
SHI07

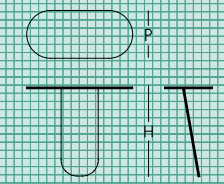

codice / code :
SHI08/09/10/11/12

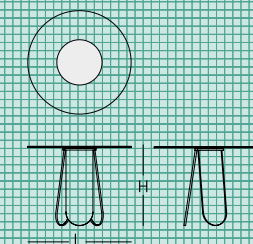

codice / code :
SHI13

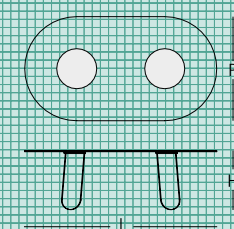

codice / code :
SHI14

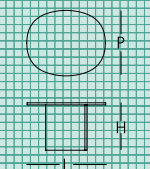

Shimmer
Patricia Urquiola

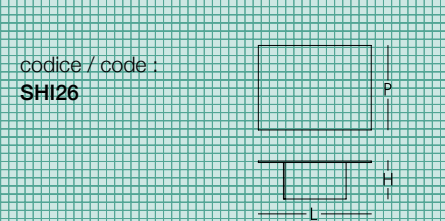
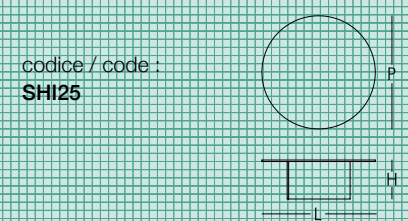
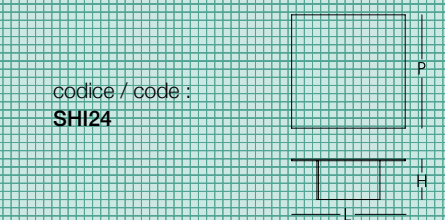
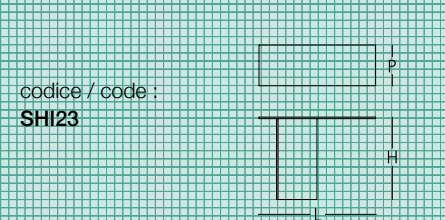
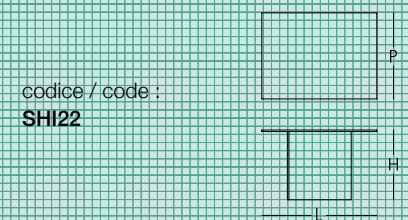
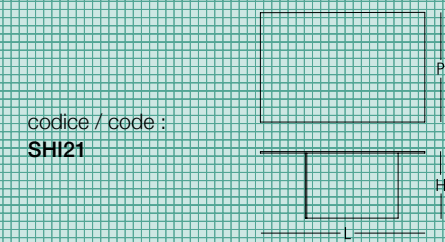
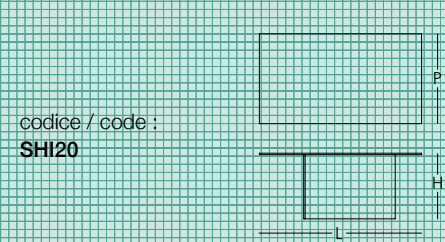
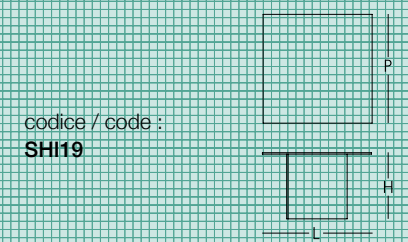
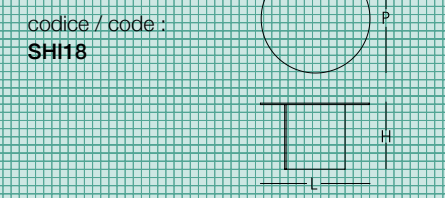
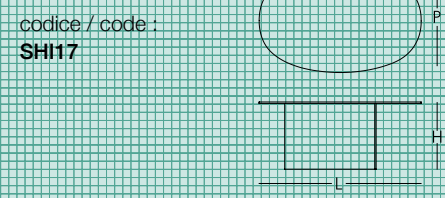
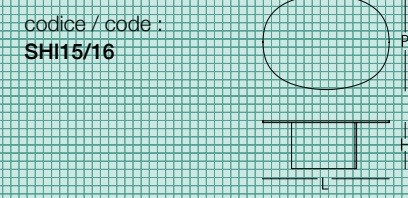

Simoon
Patricia Urquiola

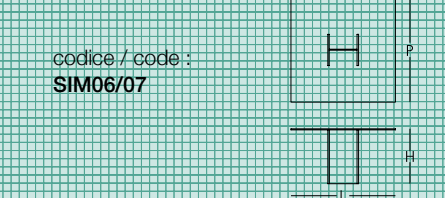
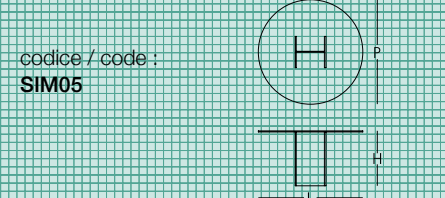
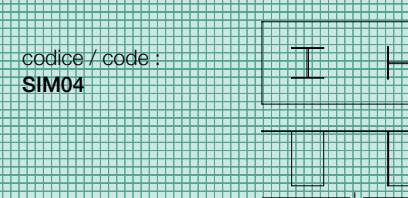
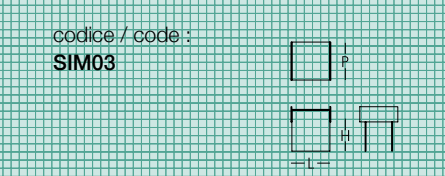
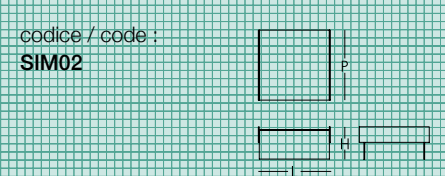
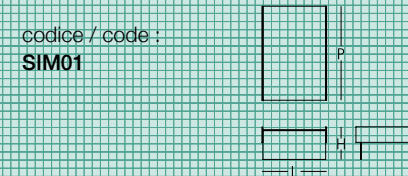

Simoon
Patricia Urquiola

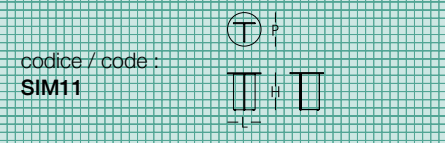
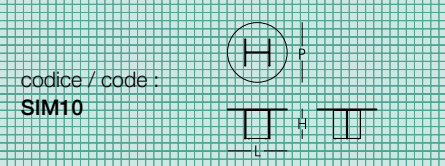
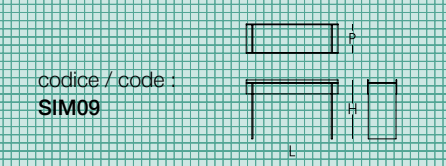
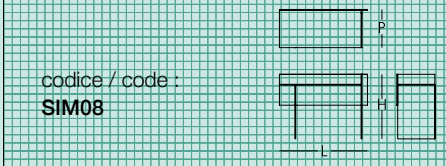

SiO₂ Bridge
Piero Lissoni, Marc Krusin, Carlo Tamborini

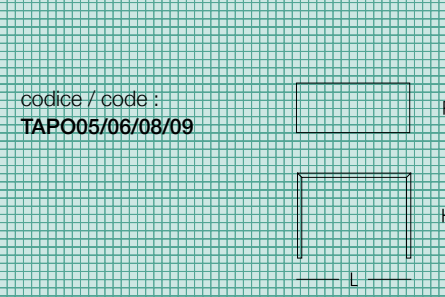
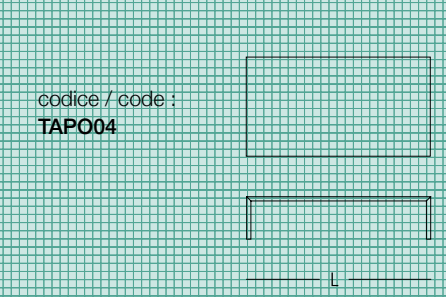
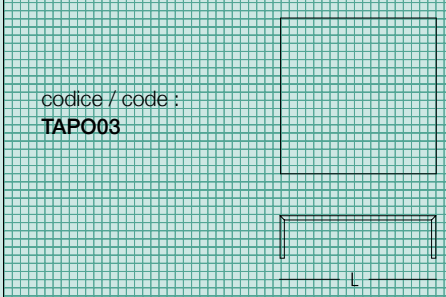

SiO₂ Tunnel
Piero Lissoni, Marc Krusin, Carlo Tamborini

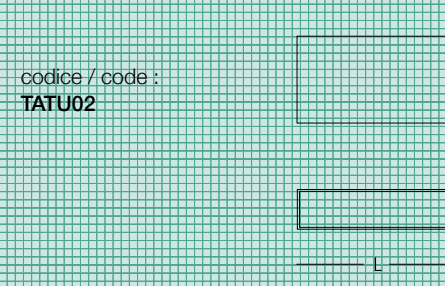
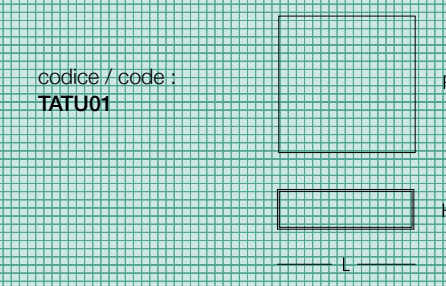

Specchio di Venere
Massimiliano Locatelli - CLS Architetti

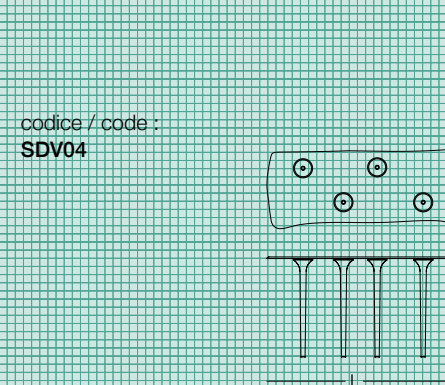
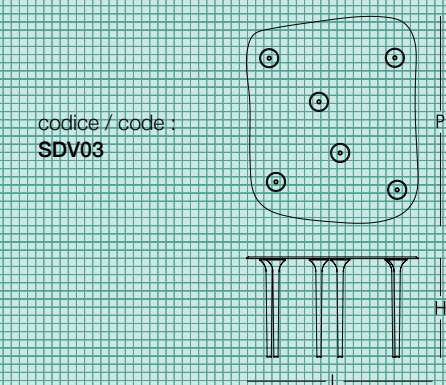
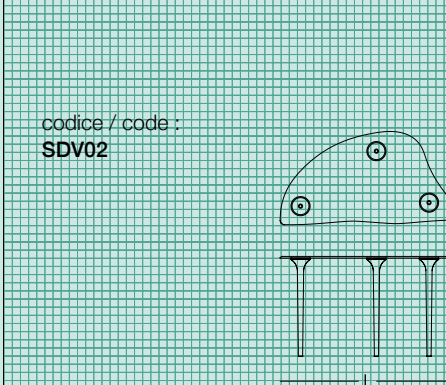

Specchio di Venere
Massimiliano Locatelli - CLS Architetti

codice / code :
SDV08

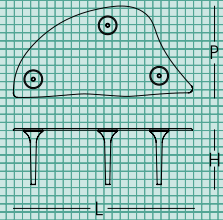

codice / code :
SDV09

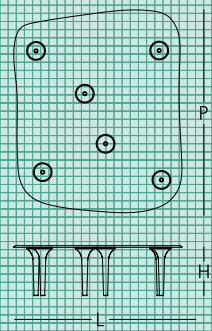

codice / code :
SDV10

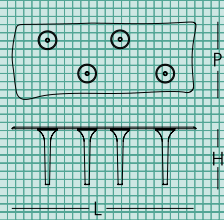

Spectrum
Piero Lissoni

codice / code :
SPE01

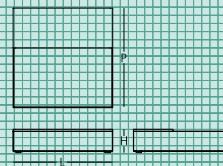

codice / code :
SPE02

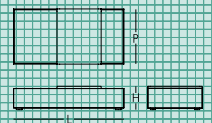

Strata
Yabu Pushelberg

codice / code :
STRA01

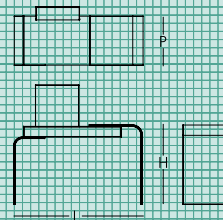

Terraliquida
Claudio Silvestrin

codice / code :
TERL01

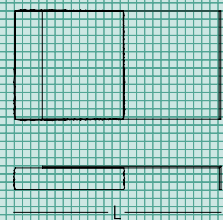

The Dark Side of the Moon
Piero Lissoni

codice / code :
THE09

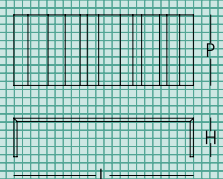

Verglas
Piero Lissoni

codice / code :
VER01/02

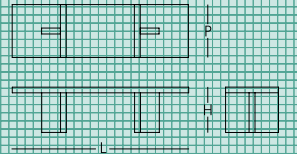

Wireframe
Piero Lissoni

codice / code :
WIR01

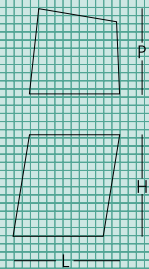

codice / code :
WIR02

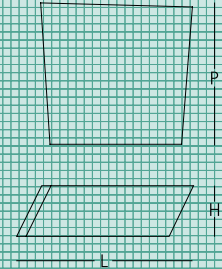

codice / code :
WIR03

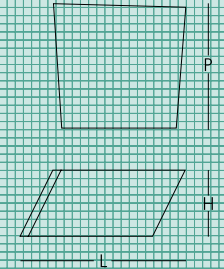

X-T
Piero Lissoni

codice / code :
XTA01/02

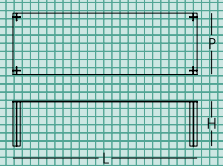

codice / code :
XTA03/04/05

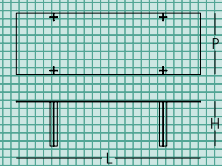

codice / code :
XTA06/07/08/09/10

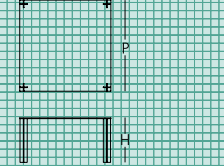

codice / code :
XTA11

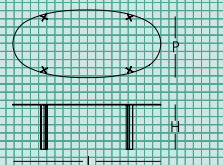

codice / code :
XTA12/13/14/15

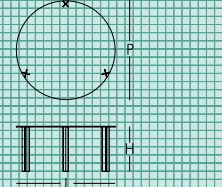

codice / code :
XTA16/17/18

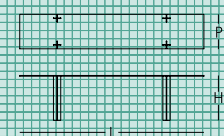

XX
Johanna Grawunder

codice / code :
XX03

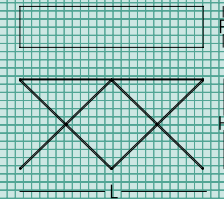

XXX
Johanna Grawunder

codice / code :
XXX01

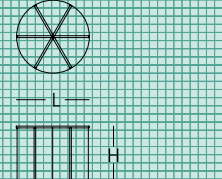

codice / code :
XXX02

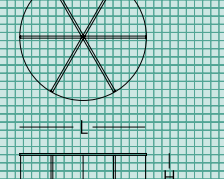

SEDUTE / SEATS



Bent Glass Bench - Bent Glass Stool

Naoto Fukasawa

codice / code :
BEB01

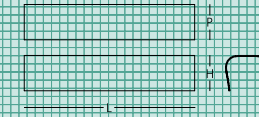

codice / code :
BES02

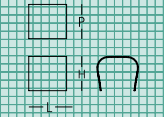

Crystal Lounge

Jean-Marie Massaud

codice / code :
CRP01

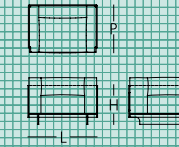

codice / code :
CRP02

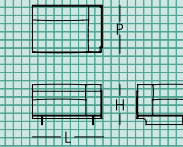

codice / code :
CRP03

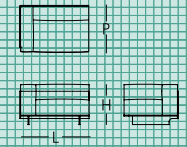

codice / code :
CRP04

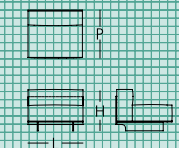

codice / code :
CRP05

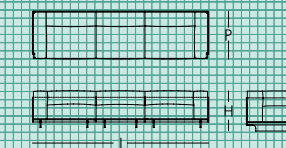

codice / code :
CRP06

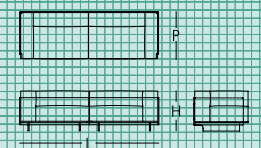

codice / code :
CRP07

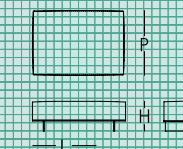

codice / code :
CRP08

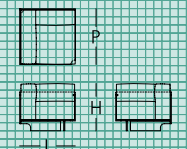

Crystal Stool

Philippe Starck

codice / code :
CRY01

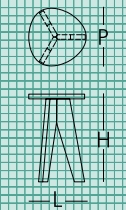

Diapositive

Ronan & Erwan Bouroullec

codice / code :
DIA01

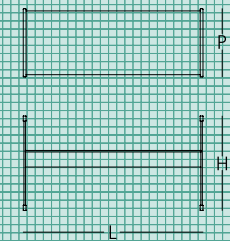

codice / code :
DIA02

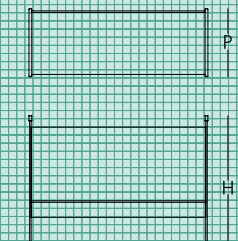

I-Beam
Jean-Marie Massaud

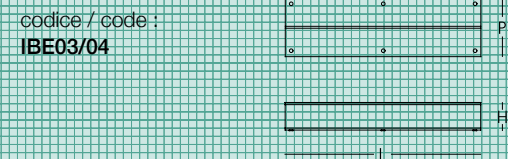
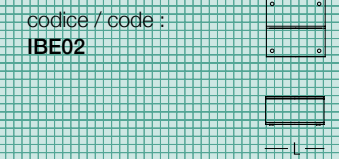

Merci Bob
Elena Cutolo

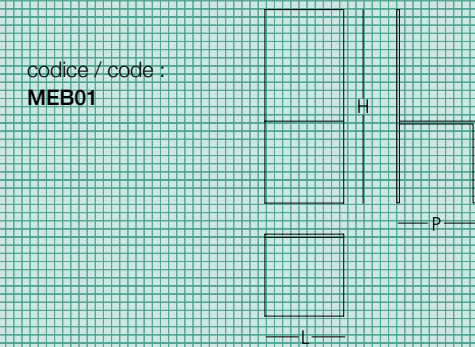

PRISM Glass Chair
Tokujin Yoshioka

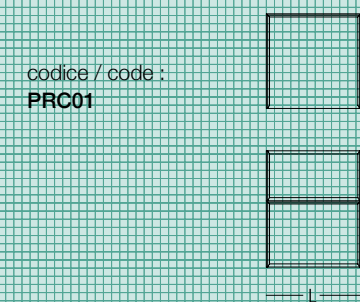

Tête-à-tête
Piero Lissoni

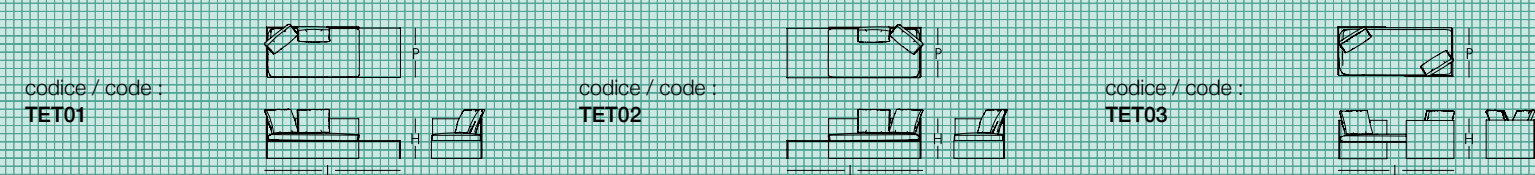

Triennale
Michele De Lucchi

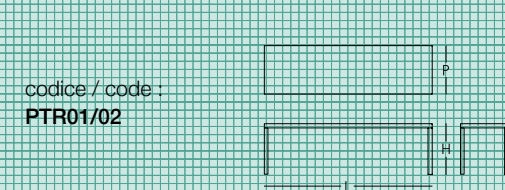

CONTENITORI / STORAGE LIBRERIE / BOOKCASES VETRINE / DISPLAY CASES

Ami-Verre
Jean Nouvel

codice / code :
AMI01

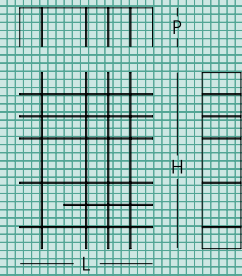

Collector
Edward Barber & Jay Osgerby

codice / code :
COR01

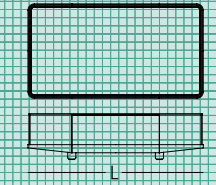

codice / code :
COR02

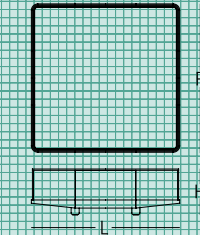

codice / code :
COR03

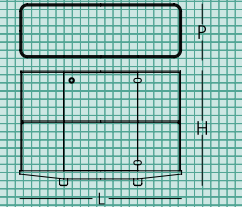

codice / code :
COR06

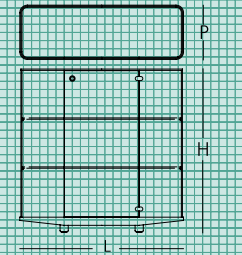

Commodore
Piero Lissoni

codice / code :
COM01

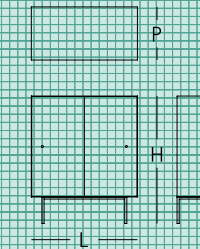

codice / code :
COM02

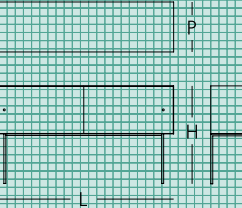

Deep Sea
Nendo

codice / code :
DEE01

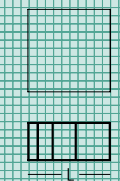

codice / code :
DEE02

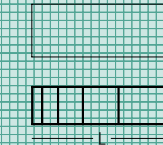

codice / code :
DEE03

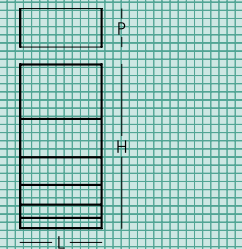

Dr Jekyll and Mr Hyde

Piero Lissoni

codice / code :
DJMH01

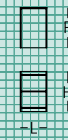

codice / code :
DJMH02

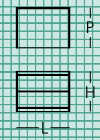

codice / code :
DJMH03



codice / code :
DJMH04

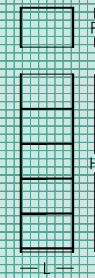

codice / code :
DJMH05

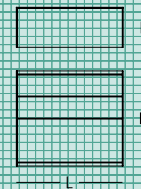

codice / code :
DJMH07

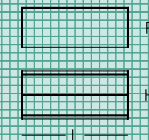

Drift

Nendo

codice / code :
DRI01

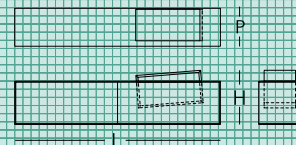

codice / code :
DRI02

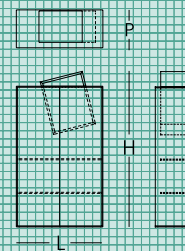

codice / code :
DRI03

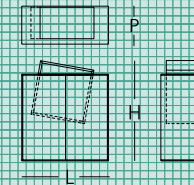

Float

Patrick Norguet

codice / code :
FLO02/07

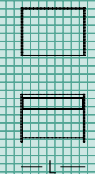

codice / code :
FLO04

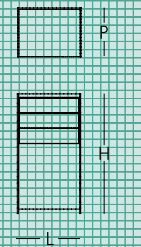

codice / code :
FLO05

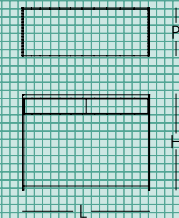

codice / code :
FLO06

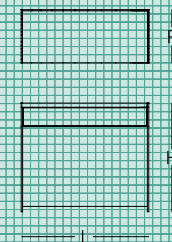

codice / code :
FLO08

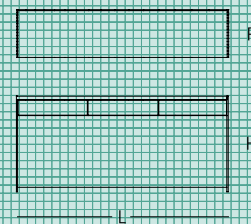

Glass Shelves #1 (1976)

Shiro Kuramata

codice / code :
KUS

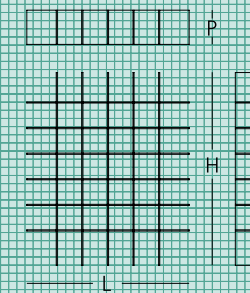

Heigh-Ho

Piero Lissoni

codice / code :
HEI01/HEI01R

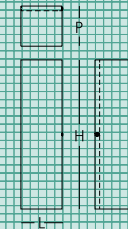

codice / code :
HEI02

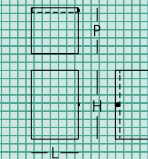

codice / code :
HEI03

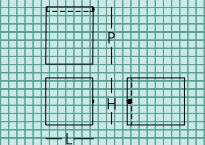

codice / code :
HEI04

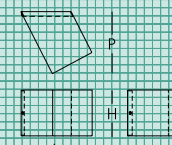

codice / code :
HEI05/HEI05R

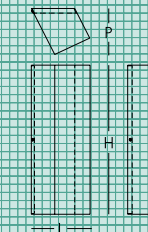

codice / code :
HEI06

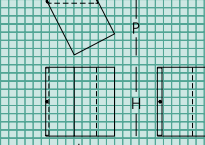

Layers

Nendo

codice / code :
LAY01

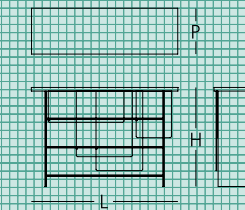

codice / code :
LAY02

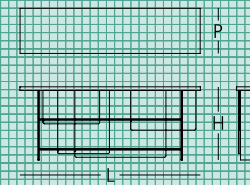

Magic Box

Piero Lissoni

codice / code :
MGB01

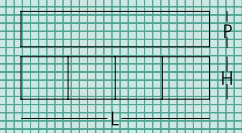

codice / code :
MGB02

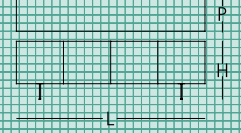

codice / code :
MGB03

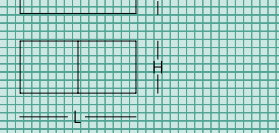

codice / code :
MGB04

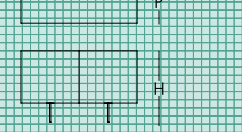

codice / code :
MGB05

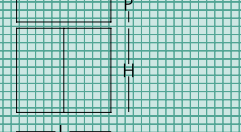

codice / code :
MGB07

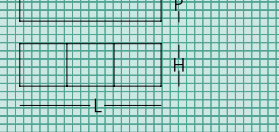

codice / code :
MGB08

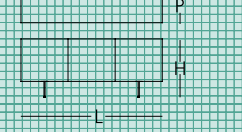

Mandarin

Piero Lissoni

codice / code :
MAN01

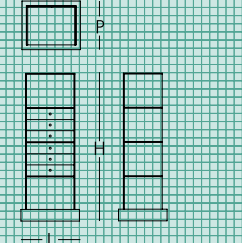

codice / code :
MAN02A

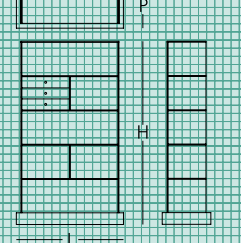

codice / code :
MAN02B

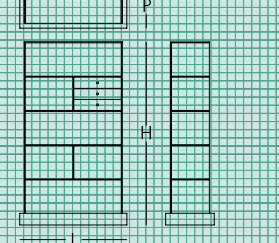

codice / code :
MAN02C

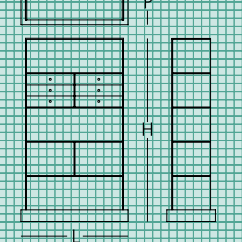

codice / code :
MAN02D

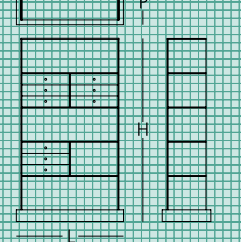

codice / code :
MAN02E

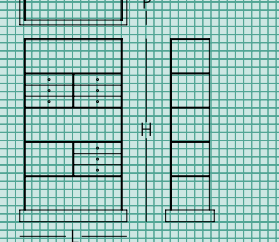

codice / code :
MAN02F

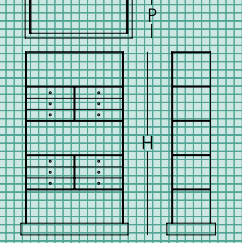

codice / code :
MAN03

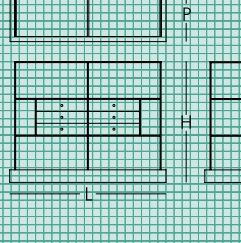

Obliquo

Piero Lissoni

codice / code :
OBL01

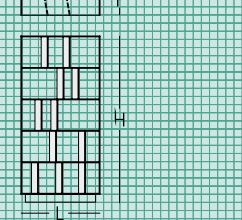

codice / code :
OBL02

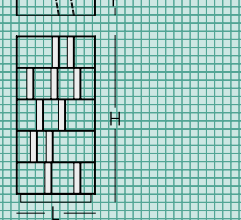

codice / code :
OBL03

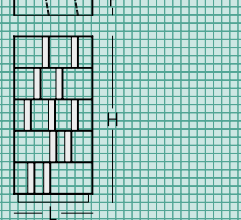

codice / code :
OBL04

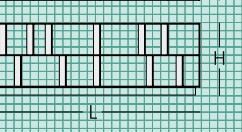

codice / code :
OBL05

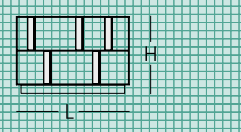

codice / code :
OBL06

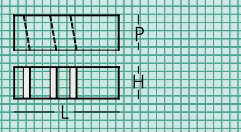

codice / code :
OBL07

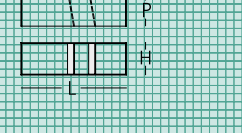

codice / code :
OBL08

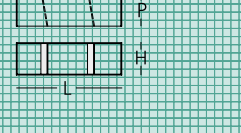

codice / code :
OBL09

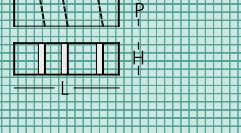

Ollie

Yabu Pushelberg

codice / code :
OLI01

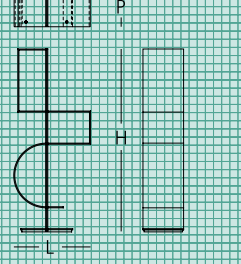

Oltralpe

Inga Sempé

codice / code :
OLT01

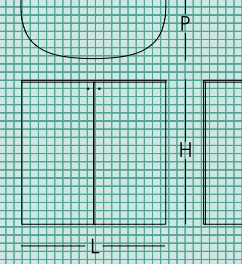

codice / code :
OLT02DX

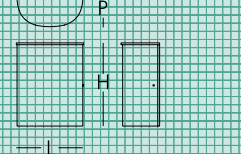

codice / code :
OLT02SX

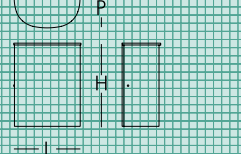

PRISM glass wardrobe
Tokujin Yoshioka

codice / code :
PRW01

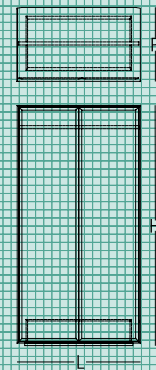

codice / code :
PRW02

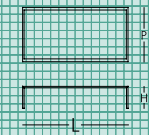

Quantum
Piero Lissoni

codice / code :
QUA01

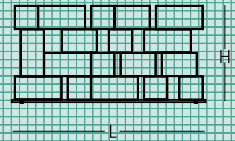

codice / code :
QUA02

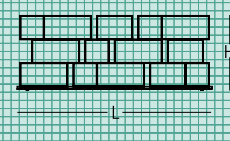

codice / code :
QUA03

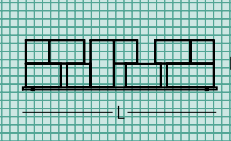

codice / code :
QUA04

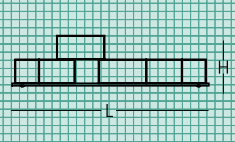

codice / code :
QUA05

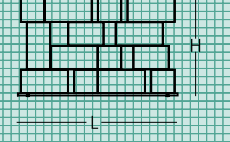

codice / code :
QUA06

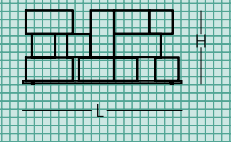

codice / code :
QUA07

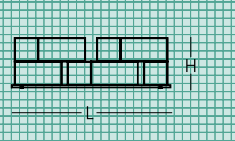

codice / code :
QUA08

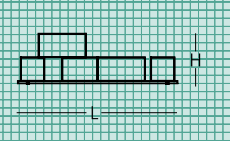

codice / code :
QUA09

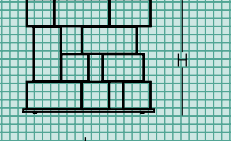

codice / code :
QUA10

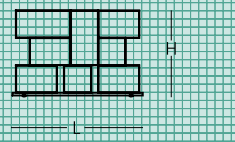

codice / code :
QUA11

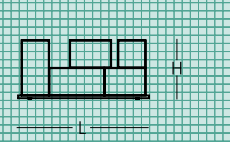

codice / code :
QUA12

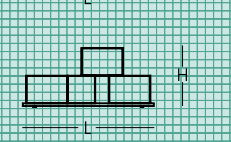

codice / code :
QUA13

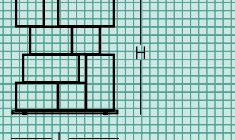

codice / code :
QUA14

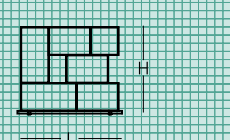

codice / code :
QUA15

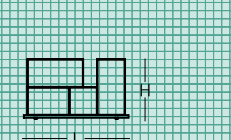

codice / code :
QUA16

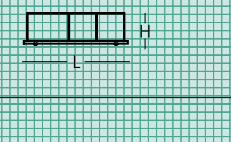

Robotin
Patricia Urquiola

codice / code :
ROB02

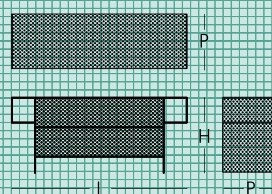

Space
Ennio Arosio

codice / code :
LSP01/05

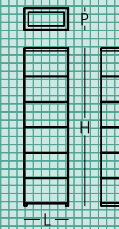

codice / code :
LSP02/06

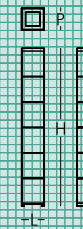

codice / code :
LSP03/07

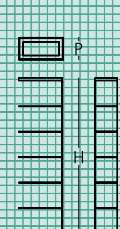

codice / code :
LSP04/08

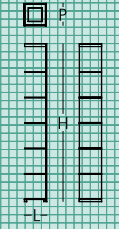

codice / code :
LSP09

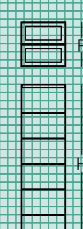

codice / code :
LSP10

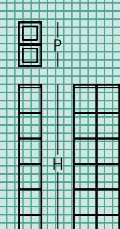

codice / code :
LSP11

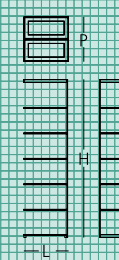

codice / code :
LSP12



Transfix

Marc Krusin, Kensaku Oshiro

codice / code :
TRX

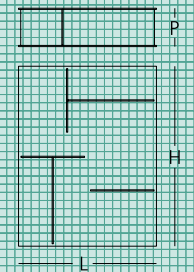

Wunderkammer

Piero Lissoni

codice / code :
WUN A

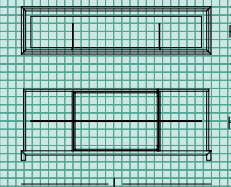

codice / code :
WUN B

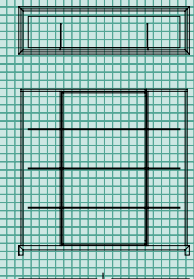

SPECCHI / MIRRORS



Andromeda (1974) Nanda Vigo

codice / code :
691C6/C8/C9

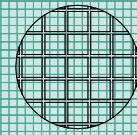

codice / code :
692C6/C8/C9

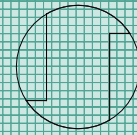

codice / code :
693C6/C8/C9

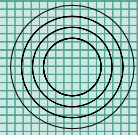

codice / code :
694C6/C8/C9

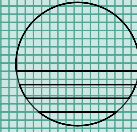

codice / code :
695C6/C8/C9

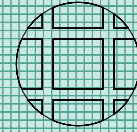

codice / code :
681Q8

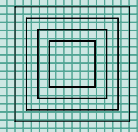

codice / code :
682Q8

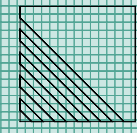

codice / code :
683Q8

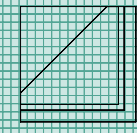

codice / code :
684Q8

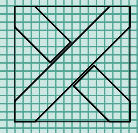

codice / code :
685Q8

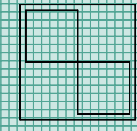

codice / code :
686Q8

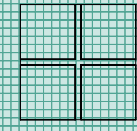

codice / code :
651R

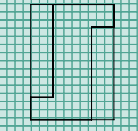

codice / code :
652R

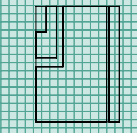

codice / code :
653R

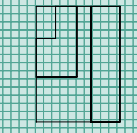

codice / code :
654R

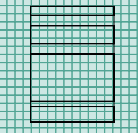

codice / code :
151L

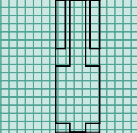

codice / code :
152L

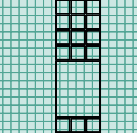

codice / code :
153L

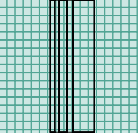

Bric Nanda Vigo

codice / code :
SB01/02

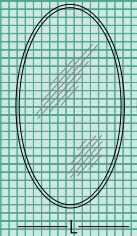

codice / code :
SB04/05/06

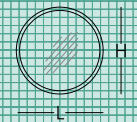

codice / code :
SB12

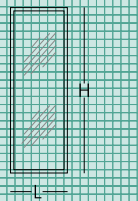

Brillante Alessandro Mendini

codice / code :
SBR01

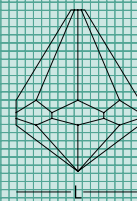

codice / code :
SBR03

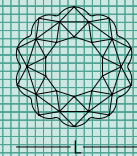

codice / code :
SBR04

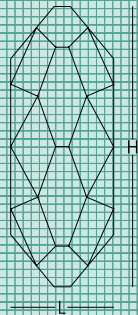

Celeste
Piero Lissoni

codice / code :
CEL01

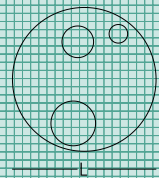

codice / code :
CEL02

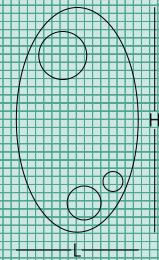

Como
Edward Barber & Jay Osgerby

codice / code :
COMO01

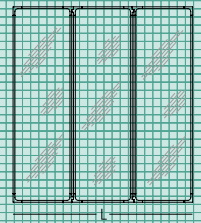

codice / code :
COMO02



codice / code :
COMO03

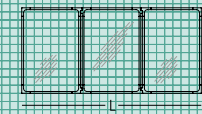

codice / code :
COMO04

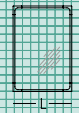

Cosmos
Nanda Vigo

codice / code :
CB08



codice / code :
CB02

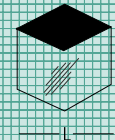

codice / code :
PL04



codice / code :
PR04

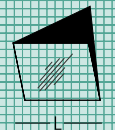

Diva
Jean-Marie Massaud

codice / code :
DIV

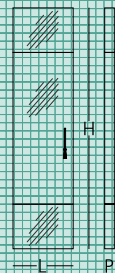

Ecco
Edward Barber & Jay Osgerby

codice / code :
ECC01

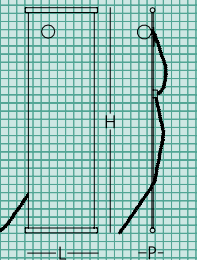

Etrusco
Ettore Sottsass

codice / code :
ETR

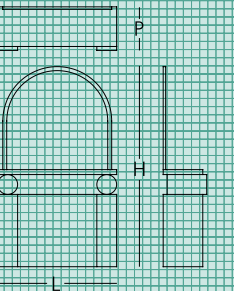

Fiction
Jean-Marie Massaud

codice / code :
FIC01

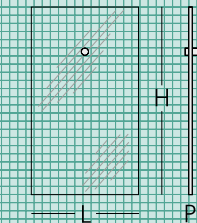

codice / code :
FIC02

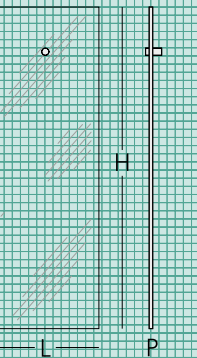

Giano a Stelo
Opera Design

codice / code :
SGI01

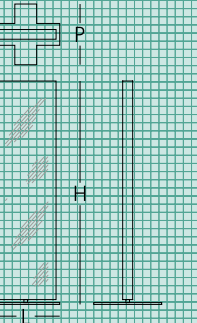

Gli Specchi di Dioniso
Ettore Sottsass

codice / code :
DIONISO1

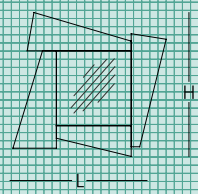

codice / code :
DIONISO2

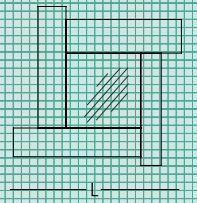

codice / code :
DIONISO3

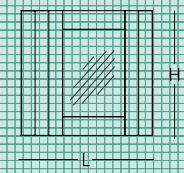

codice / code :
DIONISO4

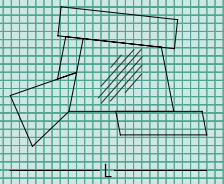

codice / code :
DIONISO5

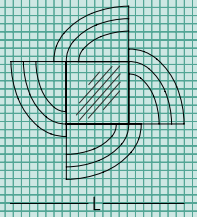

codice / code :
DIONISO6

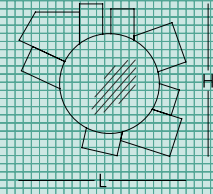

I Massi specchi
Claudio Silvestrin

codice / code :
SMA01/03

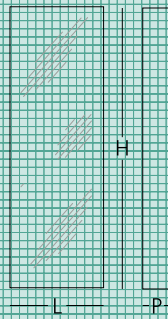

codice / code :
SMA02/04

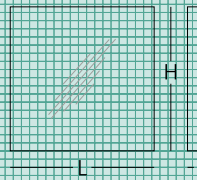

Kooh-I-Noor specchi
Piero Lissoni

codice / code :
KOS01/02

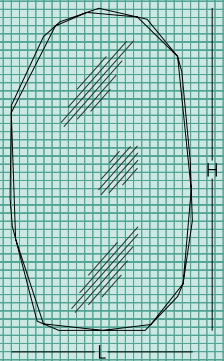

Leon Battista
Laudani & Romanelli

codice / code :
LEO01

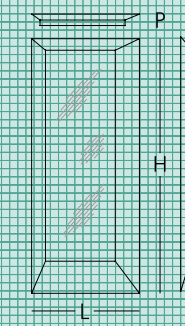

codice / code :
LEO02/03

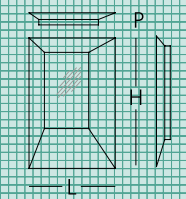

Lesena
Alessandro Mendini

codice / code :
SL01

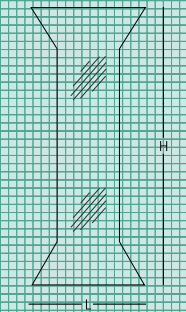

Maestrato
Piero Lissoni

codice / code :
MAE01

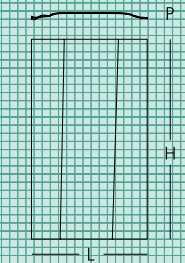

codice / code :
MAE02

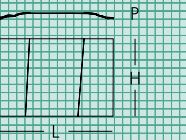

Mandala
Ettore Sottsass

codice / code :
SMS

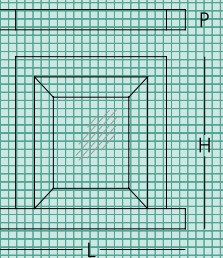

Marlene
Philippe Starck with S.Schito

codice / code :
MAR01

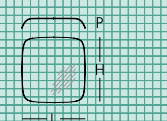

codice / code :
MAR02

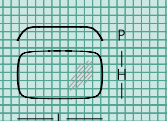

codice / code :
MAR03

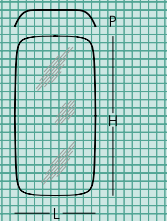

codice / code :
MAR04

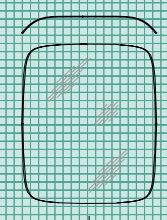

Menteur
Philippe Starck

codice / code :
MENT01

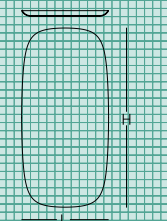

codice / code :
MENT02

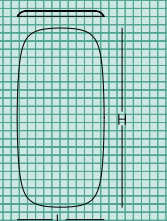

codice / code :
MENT03

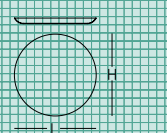

codice / code :
MENT04

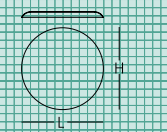

Mirror Mirror
Jasper Morrison

codice / code :
MIR09/12

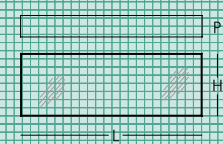

codice / code :
MIR10

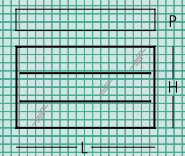

codice / code :
MIR11

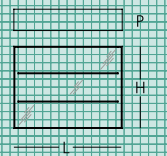

Onda
Alessandro Mendini

codice / code :
SO01

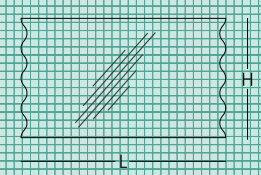

codice / code :
SO02

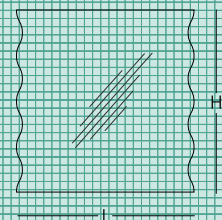

codice / code :
SO03

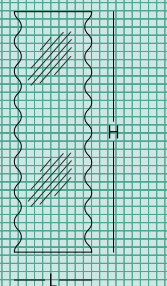

Palanco
Ronan & Erwan Bouroullec

codice / code :
PAL01/02

codice / code :
PAL03

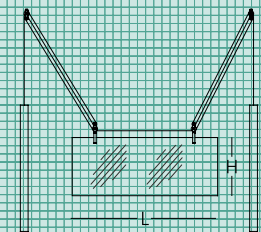

PRISM Mirror specchi
Tokujin Yoshioka

codice / code :
PRI01

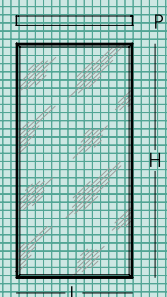

codice / code :
PRI03

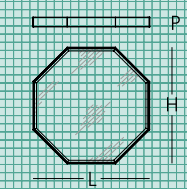

Rokokò
Nanda Vigo

codice / code :
ROKOKÒ 01/02

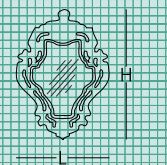

codice / code :
ROKOKÒ 03/04

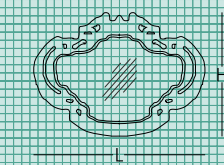

Scornice
Nanda Vigo

codice / code :
SC01

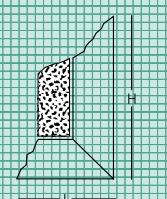

codice / code :
SC06

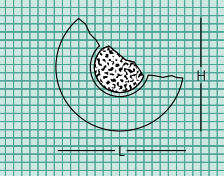

Scribble
Yabu Pushelberg

codice / code :
SCRI01

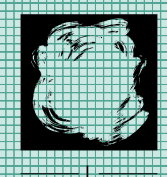

codice / code :
SCRI02

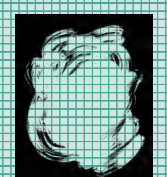

codice / code :
SCRI03

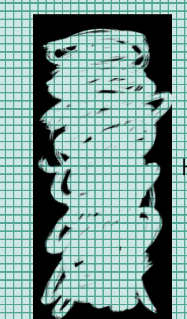

Settecento
Alessandro Mendini

codice / code :
SSV01/02/03

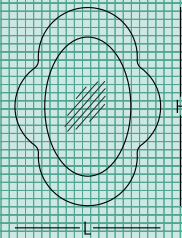

Shibam 1
Ettore Sottsass

codice / code :
SHIBAM01

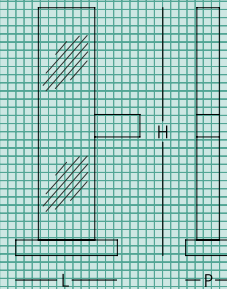

Shibam 2
Ettore Sottsass

codice / code :
SHIBAM02

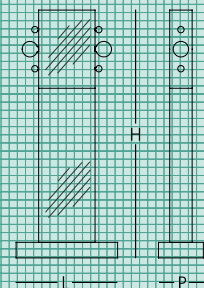

Shimmer specchi
Patricia Urquiola

codice / code :
SHS01

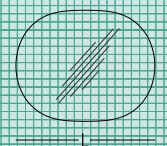

codice / code :
SHS02

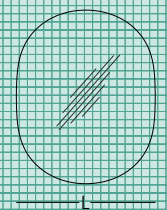

codice / code :
SHS03

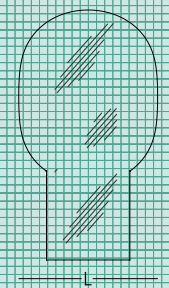

codice / code :
SHS04/05



Specchio di Proust
Alessandro Mendini

codice / code :
SDP01

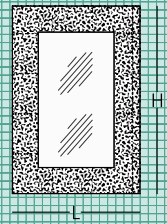

Spizzo
Cinzia Ruggeri

codice / code :
SP01

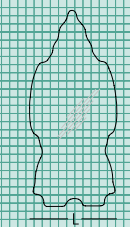

codice / code :
SP02

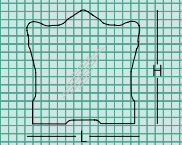

Sturm und Drang
Piero Lissoni

codice / code :
STU01

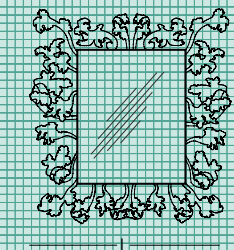

codice / code :
STU02

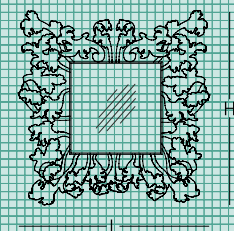

Sybilla
Ettore Sottsass

codice / code :
SYB

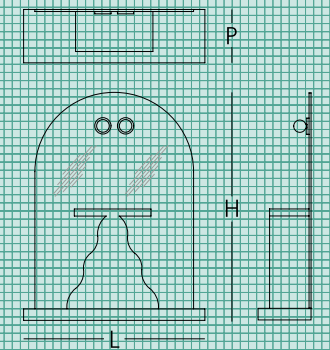

COMPLEMENTI / COMPLEMENTS



Angelo e Angela
Jean-Marie Massaud

codice / code :
ANG01

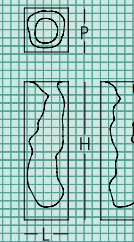

codice / code :
ANG02

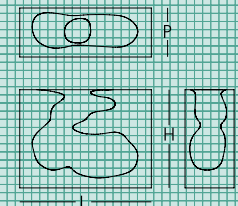

Fragment *paravento*
Nendo

codice / code :
FRA04

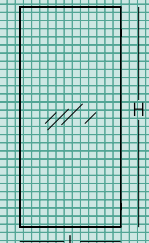

PRISM *partition*
Tokujin Yoshioka

codice / code :
PRP01

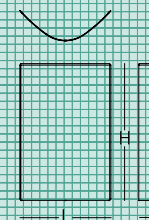

Rayures
Ronan & Erwan Bouroullec

codice / code :
RAY01

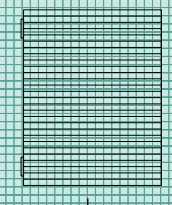

codice / code :
RAY02

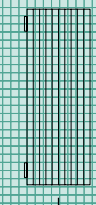

codice / code :
RAY03

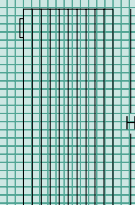

codice / code :
RAY04

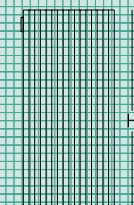

codice / code :
RAY05-MIRROR

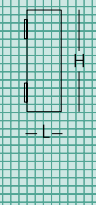

codice / code :
RAY06

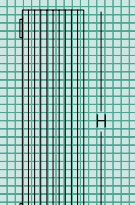

Rayures
Ronan & Erwan Bouroullec

codice / code :
RAY07

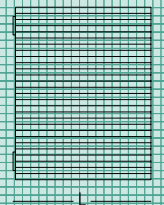

codice / code :
RAY08

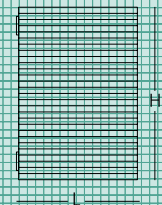

codice / code :
RAY09

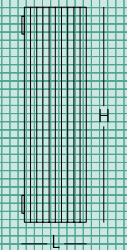

codice / code :
RAY10-MIRROR

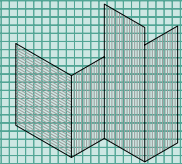
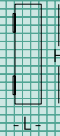

COMPOSITION 1

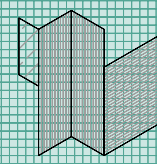

COMPOSITION 2

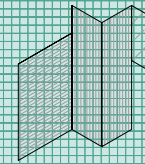

COMPOSITION 3

Telegrafo
Piero Lissoni

codice / code :
TEL01

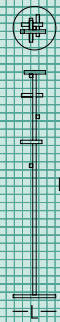

Transformer
Piero Lissoni

codice / code :
TRN01



codice / code :
TRN02



codice / code :
TRN03

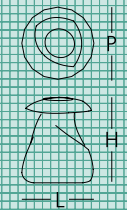

Tutube
Marc Krusini

codice / code :
TUT01/02



MENSOLE / SHELVES



Everywhere
Studio GL

codice / code :
EVE01/02/03/04

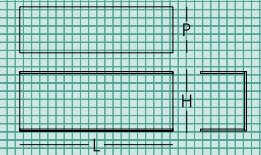

Kazimir
Michael Anastassiades

codice / code :
KAZ01

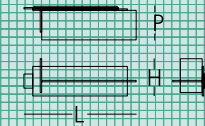

codice / code :
KAZ02

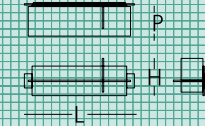

codice / code :
KAZ03

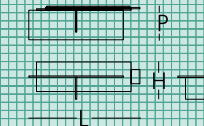

codice / code :
KAZ04

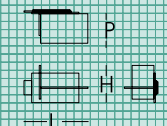

codice / code :
KAZ05

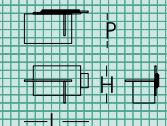

codice / code :
KAZ06

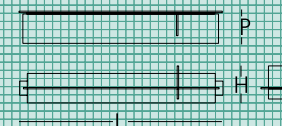

Light-Light
Nanda Vigo

codice / code :
MLI01/02/03

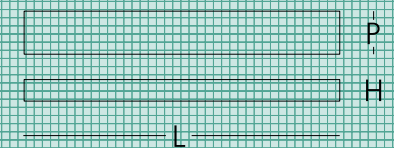

On
Ennio Arosio

codice / code :
MON01/02/03/04

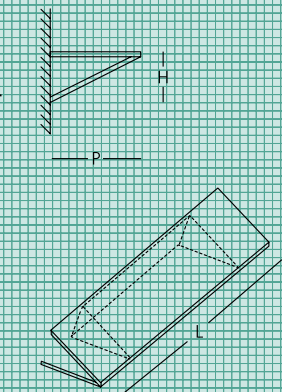



Cristalli laccati / Lacquered glass

Cristalli laccati / Lacquered glass

140 - DISEGNI TECNICI + FINITURE



CRISTALLI LACCATI LUCIDI /
GLOSSY LACQUERED GLASS

CRISTALLI LACCATI OPACHI /
MATT LACQUERED GLASS



140 - DISEGNI TECNICI + FINITURE

Cristalli trasparenti / Transparent glass



119. azzurro acqua

97. blu profondo

120. lilla

121. rosa aurora



122. rosso Siena

102. ambra

104. ruggine

113. verde bosco



115. giallo sole

116. grigio caldo

117. arancio rosato

118. cedro

CRISTALLI TRASPARENTI COLORATI /
TRANSPARENT COLOURED GLASS



GLAS ITALIA

*Via Cavour 29, 20846
Macherio (MB) - ITALY*

*glas@glasitalia.com
glasitalia.com*

CREDITS

*Progetto grafico:
Le Dictateur Studio*

*Stampato da:
O.G.M. SpA*

*Fotografia:
Paola Pansini
Cesare Chimenti
Claire Lavabre
Kenichi Somehara
Tommaso Sartori
Mattia Iotti*



